



Original instructions

Pallet stacker

FXV 14 N
FXV 16 N



1537 1538 2376 2377

11748011551 EN - 02/2021 - 09

first in intralogistics

Address of manufacturer and contact details ▶

STILL GmbH
Berzeliusstraße 10
22113 Hamburg, Germany
Tel. +49 (0) 40 7339-0
Fax: +49 (0) 40 7339-1622
Email: info@still.de
Website: <http://www.still.de>



1 Introduction

Your industrial truck	2
General	2
CE labelling	3
Copyright and property rights	3
EC declaration of conformity	4
Identification label	5
Rules for the operating company of industrial trucks	5
Eco-design requirements for electric motors and variable speed drives	6
Spare parts list	7
Proper usage	8
Description of use and climatic conditions	8
Unauthorised use	9
Explanation of symbols used	9
Disposing of components and batteries	9

2 Safety

Safety regulations	12
Safety regulations for handling consumables	13
Permissible consumables	13
Oils	13
Hydraulic fluid	14
Battery acid	14
Disposal of consumables	15
Emissions	16
Noise emission values	16
Vibration characteristics for vibrations to which the body is exposed	16
Residual dangers, residual risks	17
Stability	17
Definition of responsible persons	18
Operating company	18
Specialist	18
Drivers	18
Safety tests	20
Regular safety inspection of the truck	20

3 Overviews

Overview	22
General view	22
General view of the technical compartment	23
Operating and display devices	24
Driver's compartment	24
Electronic key (option)	25
Display operating unit	27
Markings	28
Location of markings	28
Serial number	29

4 Use

Technical description	32
List of checks prior to start-up	34
Starting up	35
Checks and actions prior to commissioning	36
Checking the emergency off switch	36
Checking the brakes	36
Checking the horn	37
Truck operating instructions	38
Stepping on/off the truck	40
Operation of operator presence detection	41
Driver's compartment settings	43
Adjusting the seat	43
Adjusting the floor	43
Seat heater option	44
Using the display-operating unit	45
Selection buttons	45
Display of the drive wheel position	45
Operation of the display unit	45
Driving safety guidelines	51
Driving	52
Defining directions	52
Driving	52
Braking	53
Horn	54

Drive program	55
Joystick function (option)	56
Steering Knob option	57
Using the truck on a slope	59
Operating the FleetManager™ option	61
Description of the FleetManager option	61
Commissioning a truck equipped with the FleetManager™ option	62
FleetManager™ option: Colour code for the LEDs	63
Disconnecting a truck equipped with the FleetManager™ option	65
Transporting loads	67
Load handling safety rules	67
Grabbing a loading unit	67
Transporting pallets or other containers	68
Lift control elements	69
Reading the capacity plate	71
Progressive stopping of the carriage in the lower position	72
Handling a single load	73
Driving assistance system: Dynamic Load Control	77
Description of the Dynamic Load Control (DLC)	77
The No Dynamic Load Control (DLC) display	78
Using Dynamic Load Control (DLC) version 1	79
Using Dynamic Load Control (DLC) version 3	81
Rules for using the Dynamic Load Control	84
Cold store usage (optional)	87
Parking the truck	89
Handling the battery	90
Battery type	90
Order picking	90
Opening and closing the battery hood	91
Charging the battery using an external charger	92
Changing the side access battery	94
Handling the truck in an emergency	99
Emergency lowering of the mast	99
Truck towing procedure	100
Handling the truck in specific situations	102
Slinging the truck	102
Lifting the truck	103
Transporting the truck	103

Transporting the truck in the lift	104
Driving on loading bridges	104

5 Maintenance

General maintenance information	106
General	106
Servicing and maintenance personnel training and qualification	107
Battery maintenance staff	107
Maintenance operations that do not require special training	107
Ordering spare parts and consumables	107
Safety guidelines for maintenance	108
Servicing and maintenance measures	108
Working on the electrical equipment	108
Safety devices	108
Technical data for inspection and maintenance	109
Recommended lubricants	110
Accessing the technical compartment	111
1000-hour maintenance plan	113
5000-hour maintenance plan	114
10,000-hour service plan	114
Chassis, bodywork and fittings	115
Cleaning the truck	115
General information on battery maintenance	117
Checking the condition of the forks	118
Steering and wheels	119
Checking the condition of the wheels	119
Electrical equipment	120
Cleaning and blowing out the electrical components	120
Checking the battery acid level and electrolyte density	120
Checking the condition of cables, terminals and the battery connector	122
Hydraulic systems	123
Checking the hydraulic system for leaks	123
Checking the hydraulic oil level	123

Lift mast	125
Cleaning and lubricating the chains.	125
Adjusting the length of the mast chains.	125
Checking the protective screen.	126
Storage and decommissioning	128
Storage of truck	128
Permanent Putting Out of Commission (Destruction)	129
6 Technical specifications	
FXV 14N / 16N datasheet	132
FXV 14N / 16N mast types	136

1

Introduction

Your industrial truck

Your industrial truck

General

The truck described in these operating instructions corresponds to the applicable standards and safety regulations.

If the truck is to be operated on public roads, it must conform to the existing national regulations for the country in which it is being used. The driving permit must be obtained from the appropriate office.

The truck has been fitted with state-of-the-art technology. Following these operating instructions will allow the truck to be handled safely. By complying with the specifications in these operating instructions, the functionality and the approved features of the truck will be retained.

Get to know the technology, understand it and use it safely - these operating instructions provide the necessary information and help to avoid accidents and to keep the truck ready for operation beyond the warranty period.

Therefore:

- Before commissioning the truck, read the operating instructions and follow the instructions.
- Always follow all of the safety information contained in the operating instructions and on the truck.

CE labelling

The manufacturer uses CE labelling to indicate that the truck complies with the standards and regulations valid at the time of marketing. The supplied EC declaration of conformity confirms this. The CE labelling is attached to the nameplate.

An independent structural change or an addition to the tow tractor can compromise safety, thereby invalidating the EC declaration of conformity.

The EC declaration of conformity must be carefully stored and made available to the responsible authorities.

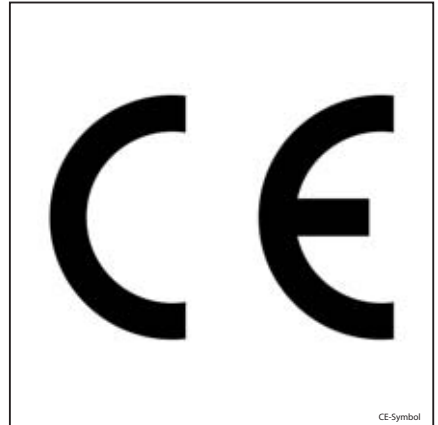

Copyright and property rights

This manual - and any excerpts thereof - may not be reproduced, translated or transmitted in any form to third parties without the express written permission of the manufacturer.

EC declaration of conformity

EC declaration of conformity**Declaration**

STILL GmbH
Berzeliusstrasse 10
22113 Hamburg
GERMANY

We declare that the machine

Industrial truck **according to these operating instructions**
Model **according to these operating instructions**

conforms to the latest version of the Machinery Directive 2006/42/EC.

Person authorised to compile the technical documents:

See EC compliance declaration

STILL S.A.S.

The manufacturer declares that the truck complies with the requirements of the EC directives valid at the time of marketing. This is confirmed by the EC declaration of conformity and by the EC labelling on the nameplate.

An independent structural change or addition to the truck can compromise safety, thus invalidating the EC declaration of conformity.

The EC declaration of conformity must be carefully stored and made available to the relevant authorities.

Identification label



NOTE

Indicate the serial number for all technical enquiries.

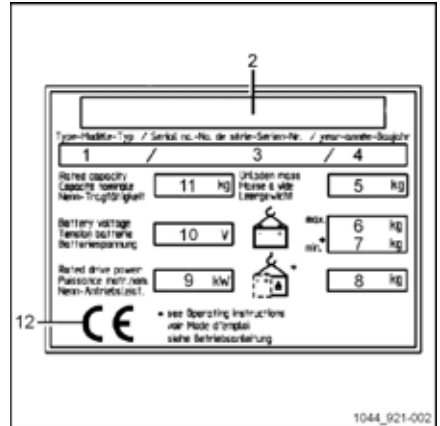

- 1 Model
- 2 Manufacturer
- 3 Serial number
- 4 Year of manufacture
- 5 Unladen weight (without battery) in kg
- 6 Maximum battery weight
- 7 Minimum battery weight (for a lithium-ion battery, the weight of the ballast container is included)
- 8 Additional weight (ballast weight) in kg
- 9 Nominal motor power (kW)
- 10 Battery voltage in V
- 11 Nominal capacity in kg
- 12 EC conformity symbol

Rules for the operating company of industrial trucks

In addition to these operating instructions, a code of practice containing additional information for the operating companies of industrial trucks is also available.

This guide provides information for handling industrial trucks:

- Information on how to select suitable industrial trucks for a particular area of application
- Prerequisites for the safe operation of industrial trucks
- Information on the use of industrial trucks
- Information on transport, initial commissioning and storage of industrial trucks

Eco-design requirements for electric motors and variable speed drives

Internet address and QR code



The information can be accessed at any time by pasting the address <https://m.still.de/vdma> in a web browser or by scanning the QR code.



Eco-design requirements for electric motors and variable speed drives

All motors in this industrial truck are exempt from Regulation (EU) 2019/1781 because these motors do not meet the description given in Article 2 "Scope", Item (1) (a) and because of the provisions in Article 2 (2) (h) "Motors in cordless or battery-operated equipment" and Article 2 (2) (o) "Motors designed specifically for the traction of electric vehicles".

All variable speed drives in this industrial truck are exempt from Regulation (EU) 2019/1781 because these variable speed drives do not meet the description given in Article 2 "Scope", Item (1) (b).

Spare parts list



The spare parts list can be downloaded by entering the address <https://sparepartlist.still.eu> into a web browser or by scanning the QR code displayed to the side.

When the web page is open, please type in the following password: **Spareparts24!**

On the next screen, please enter your email address and truck serial number to receive the link by email. Then download the spare parts list.



2511

Proper usage

Proper usage

The truck described in these operating instructions is suitable for lifting, transporting and stacking loads.

The truck should only be used for the purposes for which it was designed, as described in these instructions.

If the truck needs to be used for purposes other than those specified in these instructions, you should first:

- Obtain permission from the manufacturer
- Obtain permission from the competent authorities, if applicable

The purpose of obtaining these permissions in advance is to limit danger as far as possible.

The capacity label specifies the maximum load that can be raised. This limit must not be exceeded.

Description of use and climatic conditions

Normal use

- Indoor and outdoor use.
- Ambient temperature in tropical and Nordic regions ranging from -10°C to 45°C
- Start capability from -10°C to 45°C.
- Maximum start time of 20 seconds
- Use at up to 2000 metres above sea level.

Special use (partly with special measures) for trucks equipped with Gel or Lead batteries

- Use, for example, in the event of abrasive dust (such as AL203), lint, acid, leach, salt and incombustible substances.
- Ambient temperature in tropical regions up to 55 °C.
- Start capability at -25°C.
- Use at up to 3,500 metres above sea level.

Unauthorised use

Any danger caused as a result of unauthorised use becomes the responsibility of the operator or driver and not that of the manufacturer.

Use for purposes other than those described in these operating instructions is prohibited.

Transporting people is prohibited.

The forklift truck should not be used in areas where there is a risk of fire, explosion or corrosion, or in areas that are particularly dusty.

Stacking or unstacking is not permissible on inclined surfaces or ramps.

Explanation of symbols used

DANGER

Compulsory procedure that must be followed to avoid life-threatening danger or physical harm.

WARNING

Compulsory procedure that must followed to avoid injury.

CAUTION

Compulsory procedure that must be followed to avoid damage to and/or destruction of equipment.



NOTE

For technical requirements that require special attention.



ENVIRONMENT NOTE

To prevent environmental damage.

Disposing of components and batteries

The truck is made up of different materials.

If components or batteries must be replaced and scrapped, they must be:

- disposed of
- treated or
- recycled in accordance with regional and national regulations



ENVIRONMENT NOTE

We recommend working with a waste management company when disposing of components and batteries.



NOTE

The documentation provided by the battery manufacturer must be observed when disposing of batteries.

Disposing of components and batteries

2

Safety

Safety regulations

Safety regulations

These operating instructions, which come with the truck, must be communicated to all those concerned and in particular to personnel responsible for maintenance and driving. The employer must make sure that the forklift operator has properly understood all the safety information.

Please observe the directives and safety regulations attached, in particular:

- Information concerning the use of materials handling trucks
- Regulations concerning traffic lanes and working areas
- Appropriate behaviour, rights and responsibilities of the driver
- Use in particular areas
- Information about the weight and dimensions of pallets or any other container
- Information concerning starting, driving and braking
- Information concerning maintenance and repair

- Regular checks and technical inspections
- Recycling of lubricants, oils and batteries
- Residual risks.

Care is recommended both for the user and the person in charge (employer) with regard to adhering to all safety rules concerning the use of material-handling trucks.

When instructing forklift operators, we recommend the following points are emphasized:

- The features of the truck
- The special accessories
- The specific features of the working environment.

Train the user in how to drive the truck, until it is under proper control.

Then, and only then, proceed to transferring pallets.

Forklift truck stability is guaranteed when the unit is used correctly.

Safety regulations for handling consumables

Permissible consumables

WARNING

Consumables can be dangerous.

It is necessary to follow the safety regulations when handling these substances.

Refer to the maintenance data table for the permissible substances necessary for operation.

Oils



DANGER

Oils are flammable!

- Follow the statutory regulations
- Do not allow oils to come into contact with hot motor parts.
- No smoking, fires or flames!



DANGER

Oils are toxic!

- Avoid contact and consumption
- In case of inhalation of steam or fumes, breathe fresh air immediately.
- After contact with the eyes, rinse thoroughly with water (for at least 10 minutes) and then consult an eye specialist.
- If swallowed, do not induce vomiting. Seek immediate medical attention.



WARNING

Prolonged intensive contact with the skin can result in loss of skin oils and cause irritation.

- Avoid contact and consumption.
- Wear protective gloves!
- After any contact, wash the skin with soap and water and then apply a skin care product.
- Immediately change soaked clothing and shoes.

WARNING

There is a risk of slipping on spilled oil, particularly when combined with water!

- Collect spilled oil immediately using an oil-binding agent and dispose of it in accordance with regulations.



ENVIRONMENT NOTE

Oils are water pollutants!

Always store oil in containers that comply with the applicable regulations.

Avoid spilling oils.

Collect spilt oil immediately using an oil binding agent and dispose of it in accordance with regulations.

Dispose of old oils according to the applicable regulations.

Safety regulations for handling consumables

Hydraulic fluid



⚠ WARNING

During operation of the forklift truck, hydraulic fluids are pressurised and are hazardous to your health.

- Do not spill these fluids!
- Follow the statutory regulations
- Do not allow the fluids to come into contact with hot motor parts.
- Do not allow to come into contact with the skin.
- Avoid inhaling the spray
- Penetration of pressurised fluids into the skin is particularly dangerous if these fluids escape at high pressure due to leaks in the hydraulic system. In case of such injury, seek medical advice immediately.
- To avoid injury, use appropriate personal protective equipment (e.g. protective gloves, industrial goggles, skin protection and skin care products).



ENVIRONMENT NOTE

Hydraulic fluid is a water-polluting substance!

Always store hydraulic fluid in containers complying with the regulations.

Avoid spilling.

Spilt hydraulic fluid should be removed with oil-binding agents at once and disposed of according to the regulations.

Dispose of old hydraulic fluid according to regulations.

Battery acid



⚠ WARNING

Battery acid contains dissolved sulphuric acid. This is toxic.

- Avoid contact and consumption.
- In case of injury, seek medical advice immediately.



ENVIRONMENT NOTE

- Dispose of used battery acid in line with the applicable regulations.



⚠ WARNING

Battery acid contains dissolved sulphuric acid. This is corrosive.

- When working with battery acid, always wear protective clothing and eye protection.
- Do not allow any acid to get onto the clothing or skin or into the eyes; if this does happen, rinse immediately with plenty of clean water.
- In case of injury, seek medical advice immediately.
- Immediately rinse away spilt battery acid with plenty of water.
- Follow the statutory regulations

Disposal of consumables



ENVIRONMENT NOTE

Materials that have to be disposed of following maintenance, repair and cleaning must be systematically collected and disposed of in accordance with regulations. Observe the national regulations for your country. Work may only be carried out in areas designated for this purpose. Take care to minimise, as far as possible, any impact on the environment.

- Any spillage of fluids such as hydraulic oil, brake fluid or gear lubricant oil must be immediately soaked up with an oil-binding agent.
- The regulations for disposal of used oil are applicable.
- Any spillage of battery acid must be neutralised immediately.

Emissions

Emissions

Noise emission values

Calculated during the test cycle performed in accordance with standard EN 12053.

Acoustic pressure level in the driver's compartment			
FXV 14N, FXV 16N	L _{PAZ}	=	65 dB (A)
Uncertainty	K _{PA}	±	2.5 dB (A)

 NOTE

Lower or higher noise values may occur when using industrial trucks, e.g. due to the mode of operation, environmental factors and other sources of noise.

Vibration characteristics for vibrations to which the body is exposed

The values were determined according to EN 13059 using trucks with standard equipment according to the datasheet (driving over test course with humps).

Specified characteristics for upper limb vibrations	
Vibration characteristics	< 2.5 m/s ²

 NOTE

The vibration characteristics for bodily vibrations cannot be used to determine the actual load level of vibrations during operation. This depends on the operating conditions (state of ground, mode of operation etc.) and should therefore be determined on site, where appropriate. It is mandatory to specify the hand-arm vibrations even where the values do not indicate any hazard, as in this case.

Residual dangers, residual risks

Despite all operational precautions and compliance with standards and rules, the possibility of additional risks when using the truck cannot be entirely excluded.

The truck and all its components comply with the regulations relating to current applicable safety rules.

Persons in the vicinity of the truck must be particularly cautious and react immediately in the event of any malfunction, incident, breakdown etc.

WARNING

Personnel in contact with the truck must be informed of the risks related to using the truck.

These operating instructions draw your attention to the safety rules.

The risks are:

- Escape of consumables due to leaks, ruptured lines and tanks etc.
- Risk of accident when driving over difficult ground such as slopes, soft or irregular surfaces or in poor visibility etc.

Stability

Forklift truck stability is guaranteed only if the unit is used according to the indicated recommendations.

It is not guaranteed in the event of:

- cornering at excessive speeds
- moving with the load raised
- moving with a load that is protruding to the side (e.g. sideshift),
- turning and driving diagonally across descents or ascents,
- driving on descents or ascents with the load on the downhill side,
- loads that are too wide or too heavy,
- driving with a swinging load,
- ramp edges or steps.

- Falling, tripping etc. when moving on the industrial truck, especially in the wet, with leaking consumables or icy surfaces.
- Loss of stability due to the load being unstable or the load slipping etc.
- Risk of fire and explosion due to batteries and electrical voltages.
- Human error - Disregarding safety regulations.

It is important to adjust the speed of the truck depending on the load and ground conditions.

The stability of the truck has been tested to the latest standards. These standards only take account of the static and dynamic tilting forces that can arise during operation that complies with the specifications and operating rules. Risks caused by misuse or incorrect operation that jeopardise the stability cannot be ruled out in extreme situations.

Definition of responsible persons

Definition of responsible persons

Operating company

The operating company is the natural or legal person or group who operates the truck or on whose authority the truck is used.

The operating company must ensure that the truck is only used for its intended purpose and in compliance with the safety guidelines set out in these operating instructions.

The operating company must ensure that all users read and understand the safety information in these instructions.

The operating company is responsible for the scheduling and correct performance of regular safety checks.

It is recommended that these checks comply with national performance specifications.

Specialist

A specialist is deemed to be:

- A person whose experience and technical training has allowed him to develop relevant knowledge of industrial trucks
- A person who is also familiar with national health and safety regulations and generally recognised technical directives and conven-

tions (standards, VDE regulations, technical regulations of other European Union member states or countries that are signatories to the treaty that established the European Economic Area). This expertise allows him to assess the condition of industrial trucks in terms of health and safety

Drivers

This truck may only be driven by suitable persons who are at least 18 years of age, have been trained in driving, have demonstrated their skills in driving and handling loads, and have been specifically designated to drive the truck. Specific knowledge of the truck is also necessary.

The driver must be familiar with the operating instructions and have access to them at all times.

The driver must:

- Have read and understood the operating instructions
- Have familiarised himself with safe operation of the truck
- Be physically and mentally able to drive the truck safely

Driver rights, duties and rules of behaviour

The driver must be duly informed of his rights and duties.

The driver must be granted the required rights.

The driver must wear protective equipment (protection suit, safety helmet, industrial goggles and protective gloves) that is appropriate for the conditions, the task and the load to be lifted. The driver must also wear safety footwear to be able to drive and brake in complete safety.

⚠ DANGER

The use of drugs, alcohol or medications that affect reactions impair the ability to drive the truck.

Individuals under the influence of the above-mentioned substances are not permitted to perform work of any kind on or with the truck.

Definition of responsible persons

Prohibition of use by unauthorised persons

The driver is responsible for the truck during working hours. He must not allow unauthorised persons to operate the truck.

When leaving the truck, the driver must secure it against unauthorised use.

Safety tests

Safety tests

Regular safety inspection of the truck

Safety inspection based on time and extraordinary incidents ▷

The operating company (see chapter entitled "Definition of responsible persons") must ensure that the truck is checked by a specialist at least once a year or after noteworthy incidents.

As part of this inspection:

- A full check of the technical condition of the truck in terms of accident safety must be performed
- The truck must be thoroughly checked to detect any damage that may have been caused by improper use
- A test log must be created.

The results of the inspection must be retained until at least a further two inspections have been carried out.

The inspection date is indicated by an adhesive label on the truck.

- Arrange for the service centre to perform periodic safety inspections on the truck.
- Observe the guidelines for tests carried out on the truck in accordance with FEM 4.004.

The operator is responsible for ensuring that any defects are remedied immediately.

- Contact your service centre.



NOTE

Observe the regulations in force in your country.

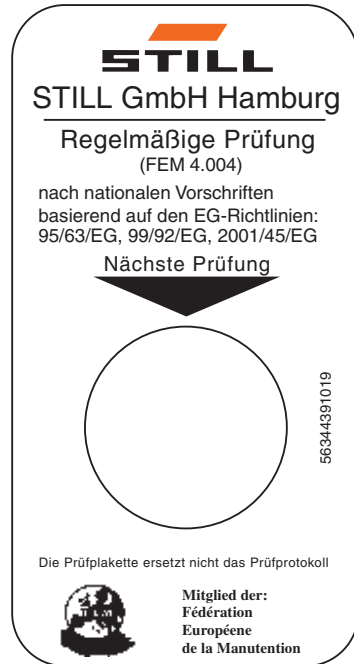

0000_003-001_V3

3

Overviews

Overview

Overview

General view

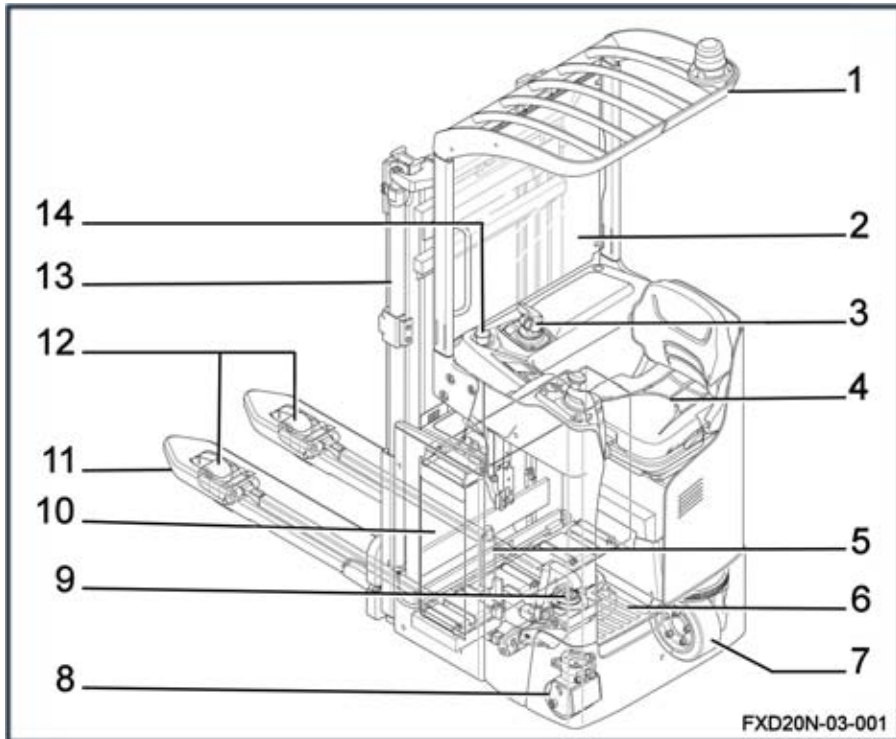

- | | | | |
|---|-------------------|----|-------------------------|
| 1 | Overhead guard | 8 | Stabiliser wheel |
| 2 | Protective screen | 9 | Operator presence pedal |
| 3 | Control module | 10 | Battery compartment |
| 4 | Seat | 11 | Forks |
| 5 | Lift cylinder | 12 | Load wheels or bogies |
| 6 | Platform | 13 | Mast |
| 7 | Drive wheel | 14 | Emergency off switch |

General view of the technical compartment

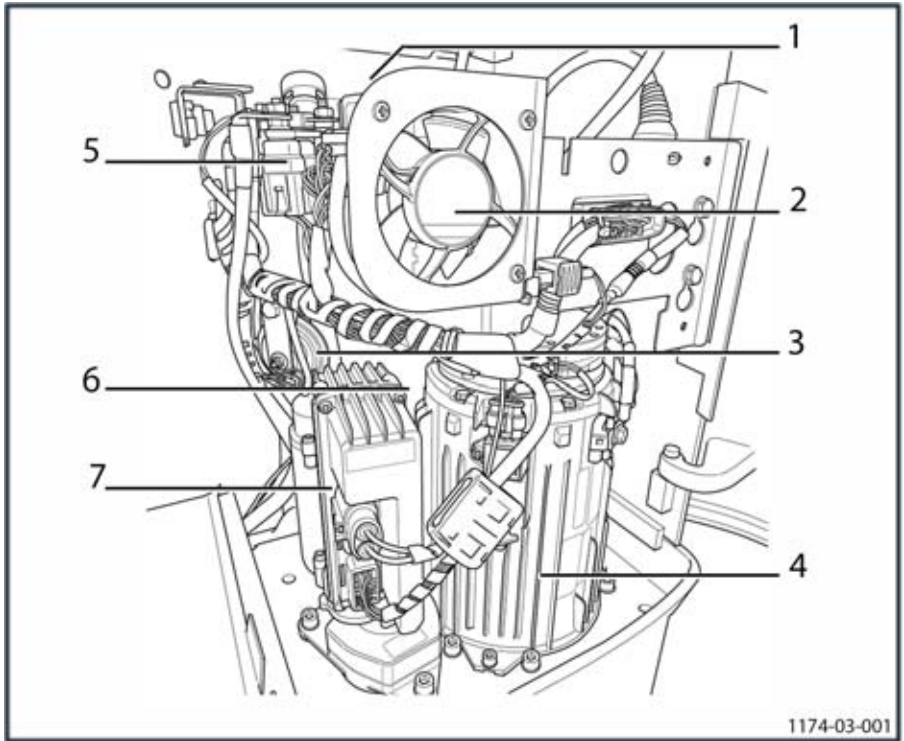

- 1 Pump-motor unit
- 2 Fan
- 3 Horn
- 4 Traction motor

- 5 Fuses
- 6 Tank
- 7 ES30-24 steering unit

Operating and display devices

Operating and display devices

Driver's compartment

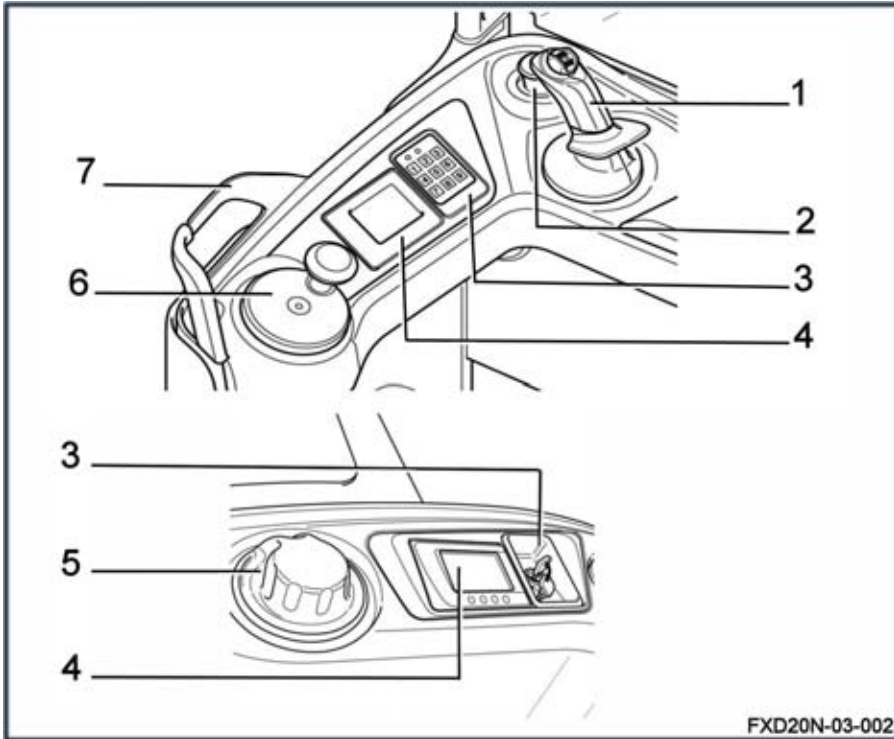

FXD20N-03-002

- | | | | |
|---|---|---|--|
| 1 | Control unit or joystick (depending on option selected) | 4 | Display |
| 2 | Emergency off switch | 5 | Control button (Steering Knob device) |
| 3 | Switch key (or electronic key) | 6 | Steering wheel |
| | | 7 | Handle for stepping on and off the truck |

Electronic key (option)



- 1 Switch ON (operating mode)
- 2 Switch OFF and awaiting code
- 3 Programming mode active
- 4 Key fault or incorrect code
- 5 Time delay of automatic switch-off

Operation	Enter	Status of LEDs	Comments
USE			
ON	*12345# (by default)	<ul style="list-style-type: none"> ○ red off ● continuous green (1) (correct PIN) ● red flashing ○ green off (4) (incorrect PIN) 	*12345 default PIN
OFF	# (3 seconds)	<ul style="list-style-type: none"> ○ red off ● green flashing (2) 	Truck power off

PROGRAMMING (truck switch OFF only (2))			
ADMINISTRATOR CODE ESSENTIAL FOR ALL ELECTRONIC KEY SETTINGS	*00000000# (by default)	<ul style="list-style-type: none"> ● continuous red ● continuous green (3) 	Once the LEDs have gone out, the electronic key automatically reverts to "operating mode".
New operator code	*0*45678#	<ul style="list-style-type: none"> ○ red off ● green flashing (2) (code accepted) 	Example of new operator code: 45678
Allocating operator codes	*2*54321#	<ul style="list-style-type: none"> ○ red off ● green flashing (2) (code accepted) 	*2*: operator reference 10 options from 0 to 9
Deleting operator codes	*2*#	<ul style="list-style-type: none"> ○ red off ● green flashing (2) (deletion accepted) 	*2*: operator reference (between 0 and 9)
Modifying administrator codes	* *9*12345678#	<ul style="list-style-type: none"> ○ red off ● green flashing (2) (code accepted) 	

Operating and display devices

PROGRAMMING (truck switch OFF only (2))			
Restoring the initial administrator code			To reactivate the default administrator code (00000000), please contact your agent or nearest dealer.
Activating the automatic switch-off	* * 2 * 1 #	● red flashing ● green flashing (5) (5 seconds before switch-off)	Power switches off automatically after 10 minutes (600 seconds by default) if the truck is not in use.
Setting the time delay of the automatic switch-off	* * 3 * 6 0 #	○ red off ● green flashing (2) (value accepted)	Example: automatically switches off after 1 minute (60 seconds) if not in use. Minimum setting = 10 seconds/maximum = 3000 seconds
Deactivating the automatic switch-off	* * 2 * 0 #	○ red off ● green flashing (2) (command accepted)	

Display operating unit

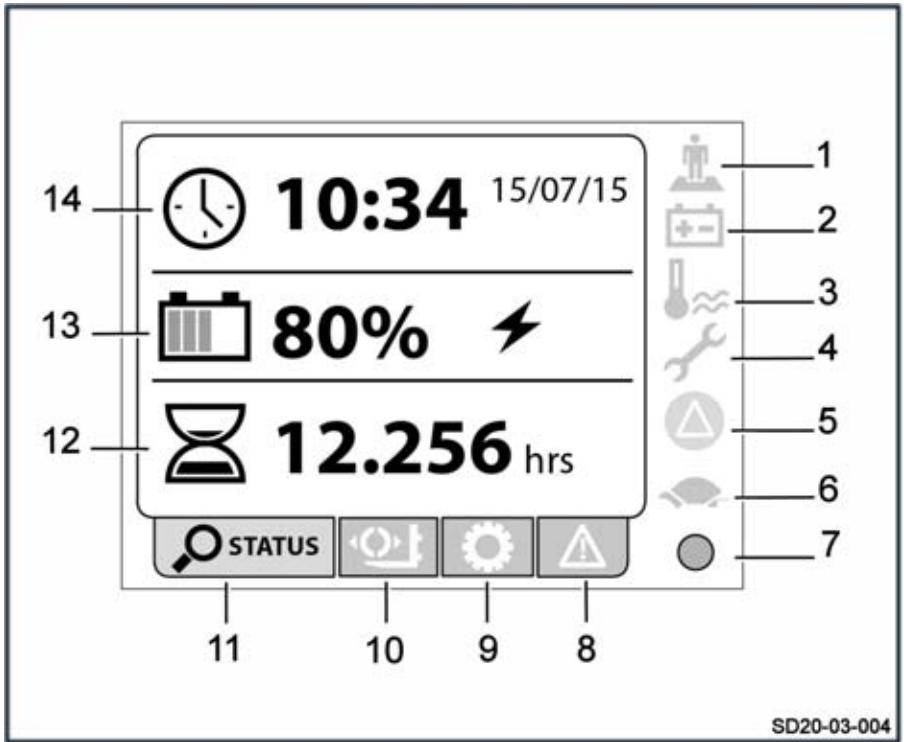

- | | | | |
|---|-----------------------------------|----|---|
| 1 | Operator presence indicator light | 9 | Settings menu |
| 2 | Battery indicator light | 10 | Load Management and Drive wheel position menu |
| 3 | Temperature indicator light | 11 | Status menu |
| 4 | Settings indicator light | 12 | Display of the operating time of the truck |
| 5 | Warning indicator light | 13 | Display of the battery charge |
| 6 | Drive programme indicator light | 14 | Display of the date and time |
| 7 | Activity indicator light | | |
| 8 | Error Code menu | | |

For more information, refer to chapter 4 **Using the display operating unit.**

Markings

Markings

Location of markings

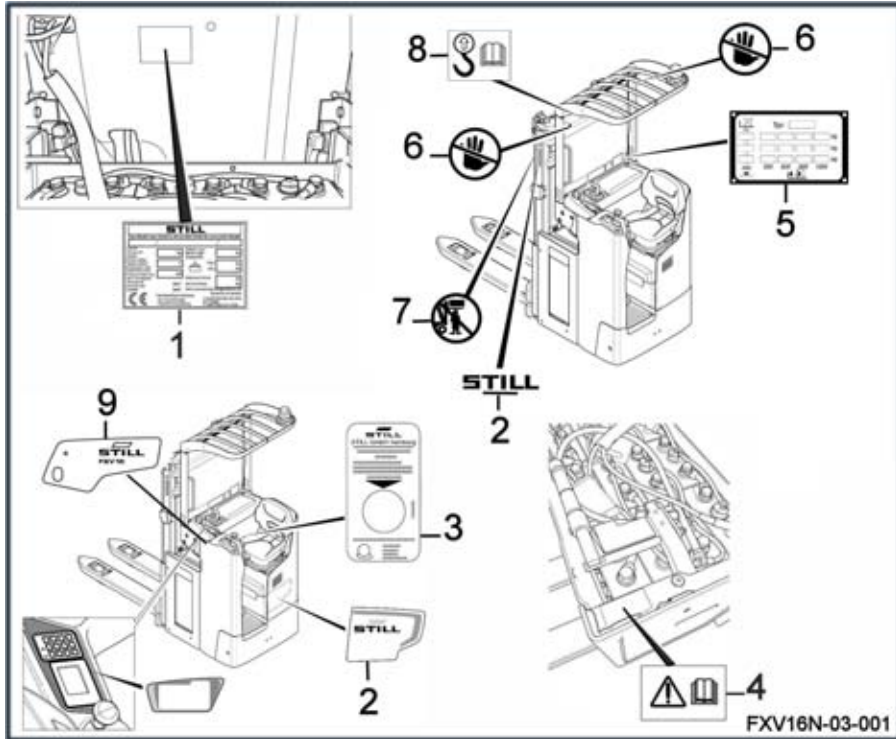

- | | | | |
|---|---|---|--|
| 1 | Identification label | 5 | Capacity label |
| 2 | Brand label | 6 | Never touch with hands label |
| 3 | Regular safety inspection of the truck label | 7 | Mast safety label |
| 4 | Danger instructions label. Consult operating instructions | 8 | Slings label. Consult operating instructions |
| | | 9 | Model label |

Serial number



NOTE

Indicate the serial number for all technical enquiries.

The serial number contains the following information:

- 1 Production location
- 2 Type
- 3 Year of production
- 4 Count number

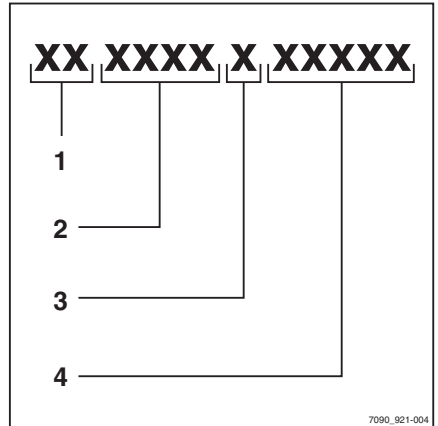

Markings

4

Use

Technical description

Technical description

Pallet stackers are intended for stacking pallets and/or containers. They allow you to transfer loads from one place to another and to pick orders.

Available models:

- FXV 14 N: 1400 kg in pallet stacker mode
- FXV 16 N: 1600 kg in pallet stacker mode
- FXV 14 N with initial lift: 1400 kg in pallet stacker mode and 2000 kg in pallet truck mode
- FXV 16 N with initial lift: 1600 kg in pallet stacker mode and 2000 kg in pallet truck mode

Features

The ride-on pallet stacker provides the operator with good visibility. The operator can cover long distances safely.

Speed during ride-on driving:

- **10 km/h** unladen
- **10 km/h** laden

Drive system

The truck drive system comprises:

- 3,0 kW traction motor
- LAC microprocessor controller to control traction and lift
- ES30–24 steering unit
- 3,2 kW pump unit

Batteries

Power is supplied by:

- A gel battery or a lead battery. The battery capacity varies between 300 Ah and 500 Ah
- Or a lithium-ion battery (the truck therefore has specific characteristics)

They are side access batteries only.

Steering

The ES30–24 electric steering offers driving precision and easier manoeuvring.

The truck is equipped with a 0,185 kW asynchronous steering motor.

The steering is controlled with a steering wheel and a control module.

The drive unit is mounted on a turntable. Steering is provided by an electric geared motor that positions the turntable.

The steering motor is controlled by a variable speed transmission. It receives information from the steering wheel and the wheel angle position.

The speed of the truck is automatically reduced when cornering.

Braking

The truck is equipped with electromagnetic brake and counter-current brake systems.

Mast

The mast is lifted using the selector located on the control module.

These masts are equipped with side lift cylinders.

FXV 14 N and FXV 16 N trucks are equipped with masts:

- S (standard) masts for heights ranging from 1844 to 4644 mm
- D (duplex) masts for heights ranging from 1844 to 3744 mm
- T (triplex) masts for heights ranging from 4266 to 5316 mm

Driver's compartment

The driver's compartment includes:

- A steering wheel and a control module
- A key switch
- A display
- An emergency off switch
- A seat
- An operator presence pedal
- A handle for stepping on and off the truck
- An overhead guard

Optional equipment available (this list is not exhaustive):

- Electronic key
- Cold store (-35°C)
- Document holder
- Steering knob
- Joystick

**NOTE**

The operating instructions can be found in the document holder, located on the technical compartment door.

List of checks prior to start-up

List of checks prior to start-up

⚠ WARNING

Damage or other defects on the forklift truck or attachments (special equipment) can result in accidents.

If damage or other faults are noticed on the truck or attachments (special equipment) during the following inspections, do not use the truck until it has been properly repaired. Do not remove or disable the safety systems and switches. Do not change the pre-set values.

⚠ WARNING

Risk of falling!

When working on high-level parts of the truck, do not use truck components for access or to stand on.

- Use suitable access equipment.

Before start-up, ensure that the truck operates correctly.

To do this, perform the following checks:

- Fork arms or other load-carrying equipment should not show any signs of noticeable damage (for example: bending, cracks, significant wear).
- Check that there are no signs of leaking consumables under the truck.
- Do not restrict the field of vision. Ensure the visible area specified by the manufacturer is observed.
- Attachment parts (special equipment) must be properly secured and function according to their operating instructions.

- Damaged or missing stickers must be replaced in compliance with the marking position table.
- The guard grille must be intact and securely mounted.
- The roller guide rails must be coated in a visible layer of grease.
- The wheels must show no signs of defects or heavy wear. They must be mounted correctly.
- Check that there are no foreign objects that could hinder the operation of the wheels and rollers.
- The warning devices (horn etc.) must work.
- The battery cover must be closed.
- Check that the covers are correctly positioned.
- The chains must be in perfect condition and must be evenly and correctly tensioned.
- The operator must be qualified to drive the truck. The operator must be able to reach the controls and operate them (especially the anti-crush device). Do not obstruct access to the controls.

Please inform your supervisor if you notice any defects.

Starting up

NOTE

- *Check that no controls are activated before starting the truck.*
- *Check that the battery hood is closed.*
- *Check that the battery is locked.*
- Check that the battery is connected.
- Check that the battery compartment hood is closed and locked correctly.
- Climb onto the truck using the handle.
- Sit on the seat.
- Press the operator presence pedal.
- Release the emergency off switch (1) if it has been pressed.
- Turn the key (2). For models equipped with an electronic key or the FleetManager™ option, enter the PIN code.

The display (3) lights up. The truck is ready for operation.

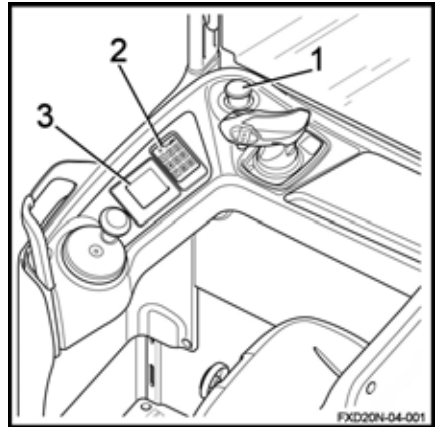

Checks and actions prior to commissioning

Checks and actions prior to commissioning

Checking the emergency off switch ▷

To check the operation of the emergency off switch, proceed as follows:

- Drive the truck
- Press the emergency off switch (1)

The truck stops immediately. The truck power supply is cut. The electrical controls and motors are no longer supplied with power.

- Pull the emergency off switch (1)

The functions are available again.

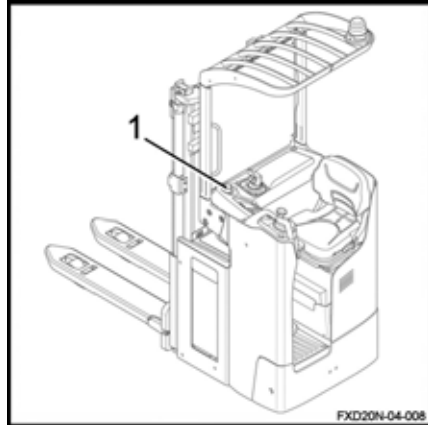

NOTE

Ensure that the stabiliser wheels operate correctly. This influences braking effectiveness.

Checking the brakes

Braking by releasing the drive switch ▷

- Drive the truck in direction (1) or (2)
- Release the drive switch

The brake is activated until the truck stops completely.

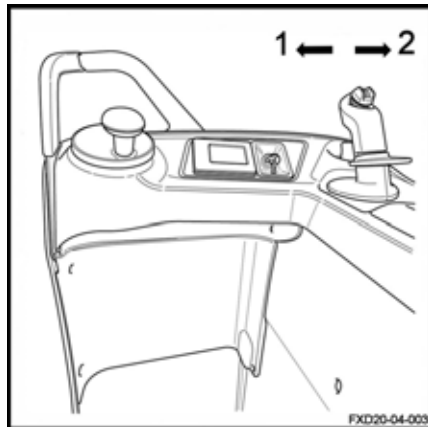

Braking by reversing the drive direction

- Drive the truck in direction (1) or (2)
- Move the drive switch in the opposite direction

The truck slows down and then moves off in the opposite direction.

NOTE

Also ensure that the stabiliser wheels operate correctly. This influences braking effectiveness.

Checking the horn

The horn is located on the rear side of the control module.

To check the operation of the horn, proceed as follows:

- Press the button (1) on the control module

The horn sounds.



Truck operating instructions

Truck operating instructions

The trucks are designed for indoor and outdoor use in non-hazardous atmospheres. The temperature should be between -10°C and $+45^{\circ}\text{C}$ and the relative humidity of the air less than 95%.



NOTE

A cold store option is available for lower temperatures.

The places where the truck is used must comply with the applicable regulations (condition of the ground, lighting etc.).

The trucks must be used on dry, clean and flat ground.

Before using the truck, it is essential to check the working environment. This check can take the form of visual inspection.

The work area must be clear. The truck's path must be free of obstacles and people.

The operator must be alert to anything that might prevent manoeuvres being carried out safely. The following may create a potential danger:

- A person near the truck
- A person below the forks when they are raised
- The operator must not use an MP3 player or any other electrical equipment that could impair awareness of his/her surroundings
- There must be no signs of oil or grease on the floor

The operator must take care when transporting a load. The load dimensions can interfere with manoeuvres and restrict the field of vision. The speed of the truck must also be reduced as the truck could tip over when breaking or cornering.

The loads must be consistent, with a maximum recommended height of 2 m.

For uses other than those shown above, please consult the After-Sales Service Centre.

It is important to use pallets that are in good condition.

Speed must be reduced when moving over obstacles to prevent the truck from becoming unbalanced and vibrations in the operator's arms.

The trucks can drive across ramps and shallow inclines. With an initial lift, they can cross larger obstacles.

WARNING

Risk of loss of stability

- Always adapt your driving to the ground conditions (uneven surfaces etc.), particularly hazardous working areas and the load.



NOTE

- *To prevent the bottom of the load lift system from scraping the ground, always move the forks to the raised position before setting off*
- *Always switch off the ignition before leaving the truck*
- *The mast protective screen must always be correctly positioned, properly secured and clean*

WARNING

Risk of damaging the truck

Ensure that the height of the mast is lower than obstacles (racks, doors etc.).

WARNING

Risk of injury

Always keep your hands on the controls. Never put your hands near moving parts and assemblies without first lowering the load arms to the ground and disconnecting the battery.

For effective protection, safety shoes must be worn.

Do not climb on the hoods of the truck (battery, chassis etc.).

⚠ WARNING

Driving safety guidelines:

- The driver must drive slowly around corners and when entering narrow passageways.
 - The driver must always maintain a safe braking distance from vehicles or people in front of him.
 - The driver must avoid stopping suddenly, making U-turns too quickly and overtaking in dangerous areas with poor visibility.
-

⚠ CAUTION

Risk of injury

Before using a side access truck, check that the battery is correctly locked.

Stepping on/off the truck

Stepping on/off the truck

**⚠ WARNING**

Risk of falling, tripping or slipping when stepping on/off the truck.

Use the handle (1) and the seat (2) to help when stepping on/off the truck.

- Hold the handle (1) with one hand
- Hold onto the seat (2) with the other hand
- Step onto the platform (3), paying close attention to your step

⚠ CAUTION

Risk of injury or impact from the edges of the truck.

The chassis is narrow. Be careful not to hit yourself on the truck when stepping onto it.

⚠ CAUTION

Risk of damaging the equipment

- Never pull on the steering wheel or control unit when climbing onto the truck.

Excessive force on the steering wheel or the control unit can damage it and cause a malfunction.

⚠ DANGER**Risk of injury**

To avoid accidental start-up, do not use the control module as a handle.

Use the handle and the seat.

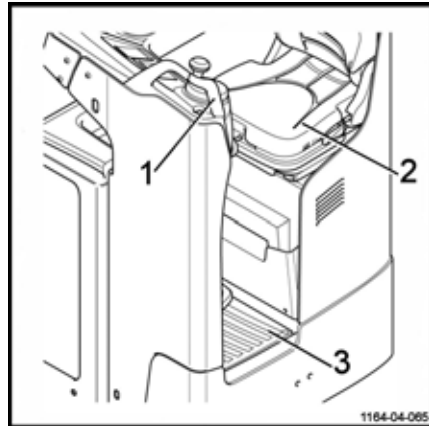

Operation of operator presence detection

The truck is equipped with two operator presence detectors:

- The chair (2)
- The presence pedal (1)

These two components are truck safety devices.

First, the forklift operator must sit on the chair (2). The operator detection contact is then activated.

The forklift operator presence pedal (1) must then be depressed before and while the truck is moving.

The pedal allows you to operate all the controls of the truck.

In reverse travel (fork direction), it is possible to rise from the chair in the event of poor visibility. The truck then travels at 2 km/h. The forklift operator presence pedal must be kept depressed.

Before rising from the chair, it is essential to slow down the truck to a very low pace and to check the working environment.

WARNING

Risk of injury

Do not rise from the chair when the truck is travelling at full speed.

NOTE

Do not rise from the chair to slow down the truck.

If the forklift operator sits down again, the truck continues to travel at a limited speed. The drive switch must be released. When the forklift operator presses the drive switch, the truck returns to its normal speed.

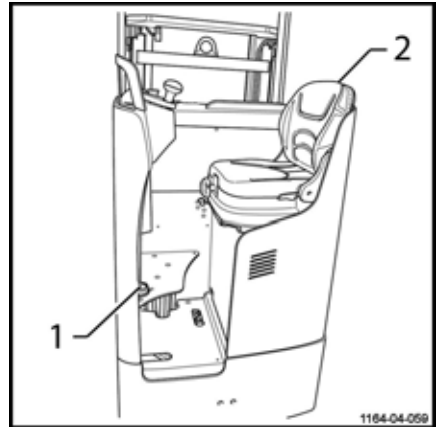

Operation of operator presence detection

CAUTION

Disabling of controls

If the operator presence pedal is released when moving:

- The truck brake is automatically activated
 - The controls no longer work
-

Driver's compartment settings

Adjusting the seat

The seat is equipped with an operator presence detector.

The operator must adjust his weight by increments of 10 kg to trigger this detection.

Proceed as follows:

- Sit on the seat
- Turn the adjustment wheel (1) until the desired weight is reached
- Put the truck into service

The seat's operator presence detector cannot be activated if the weight setting is too high or too low.

This operation also enables you to adjust the hardness of the seat.

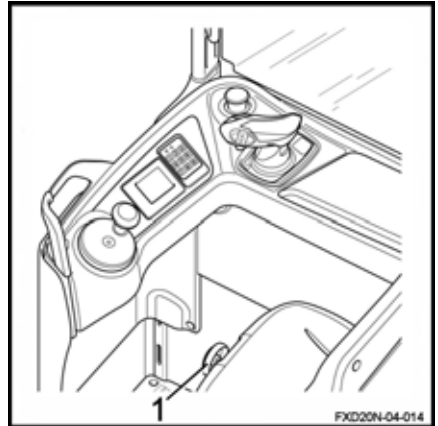

Adjusting the floor

The floor is fitted with a pressure-based height adjustment system.

To adjust the floor height, proceed as follows:

- Sit on the seat.
- Press the floor unlocking button (2) and hold it down for the duration of the operation.
- Exert pressure on the floor (3) by pushing it with your legs to obtain a good driving position.
- Release the button.

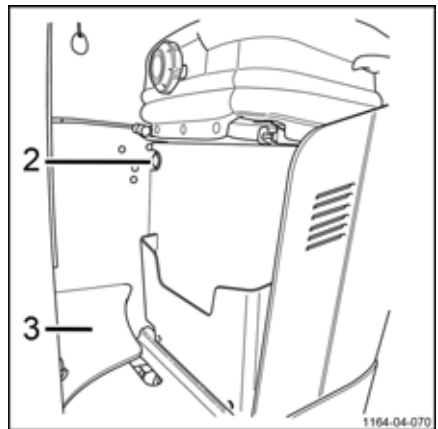

NOTE

Adjusting the floor is not possible when the truck is in cold store. The cylinder for adjustment does not work at low temperatures.

Driver's compartment settings

Seat heater option

The driver's seat may be equipped with the **seat heater** option.

The heater turns on when the operator's presence on the seat is detected.

To activate the heater, proceed as follows:

- Sit on the seat
- Adjust the weight of the operator
- Put the truck into service
- Press the LED button (1) to activate the heating

The LED button (1) illuminates to indicate that the heater is in operation.

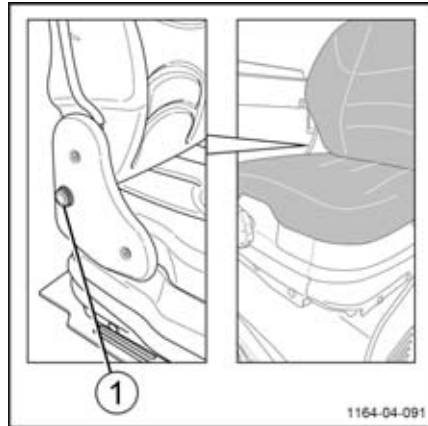

NOTE

When the driver gets up or leaves the seat, the heating stops in order to conserve battery power.

No visual information is shown on the display.

- Check whether the LED button (1) is on
- Press the LED button (1) to reactivate the heater

Using the display-operating unit

Selection buttons

The operator selects the menus using the four selection buttons:

- The **Blue Q** button (1) to select Blue Q mode, hare mode or tortoise mode
- The **left arrow** button (2) to scroll left through the drop-down menu
- The **right arrow** button (3) to scroll right through the drop-down menu
- The **confirm** button (4) to confirm the high-lighted choice on the screen



Display of the drive wheel position

The forklift operator can find out the position of the drive wheel by referring to the display.

Proceed as follows:

- Press the **left arrow** or **right arrow** button to scroll through the menu.
- Select the Wheel menu (2).
- Press the **confirm** button (1).

The position of the drive wheel is then shown on the display (3).

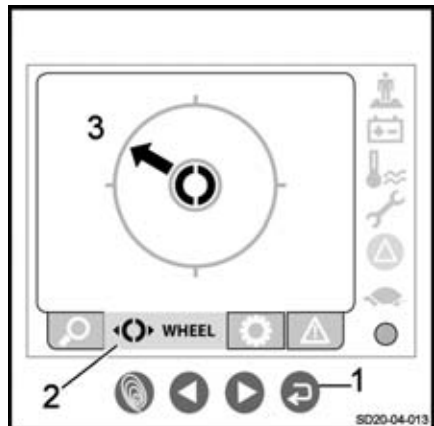

Operation of the display unit

Operator presence

For the truck to operate, the operator must be detected on the seat and then on the pedal.

When the truck is switched on, the light indicating the **operator's presence on the seat** (1) comes on and flashes.

Using the display-operating unit

- Sit on the seat

The light indicating the **operator's presence on the seat** (1) is replaced by the light indicating the **operator's presence on the pedal** (2), which flashes.

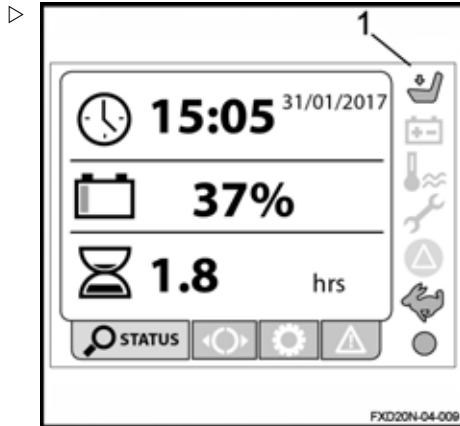

- Press the operator presence pedal with your left foot

The light indicating the **operator's presence on the pedal** (2) remains continuously illuminated for two seconds and then goes out.

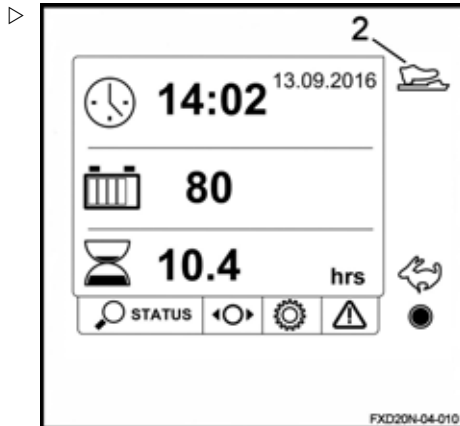

Managing battery charging

The operating unit shows the battery charge level.

The operator can refer to the battery icon (1) or (2).

The number of bars shown indicates the battery charge level.

- From 0 to 20%: 1 bar
- From 21 to 40%: 2 bars
- From 41 to 60%: 3 bars
- From 61 to 80%: 4 bars
- From 81 to 100%: 5 bars

The **battery** light (3) comes on in the event of a deep discharge of the battery or in the event of a fault.

Two distinct warnings may be displayed if the battery charge is insufficient:

- 1) 25% of charge remaining: The (3) and (4) icons flash and an audible beep sounds. A warning message appears at the (4) icon and remains on until the battery is re-charged.
- 2) 20% of charge remaining: Three regular beeps sound, lifting is restricted, the (3) icon flashes and the (4) icon remains on with a new warning message.

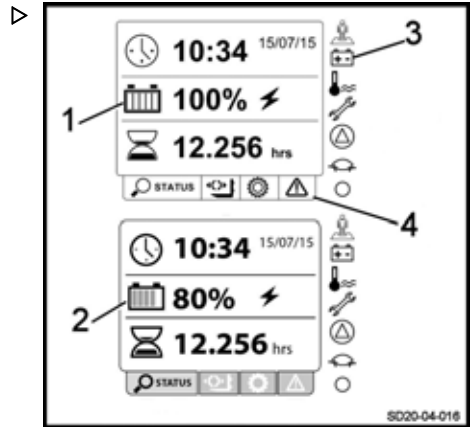

Temperature, settings and warning lights

The **temperature** light (1) comes on in the event of overheating of the traction motor or the controller.

A warning is shown on the display.

The **settings** light (2) comes on to indicate the date of the next maintenance.

A warning is shown on the display.

The **warning** light (3) comes on in the event of a fault in a truck component.

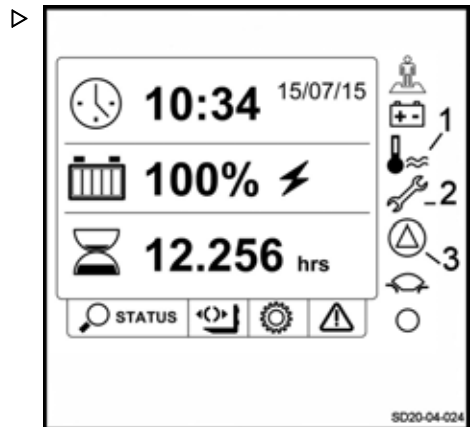

Using the display-operating unit

Drive program

The **drive program** light (1) is permanently illuminated when a travel mode is selected.

There are three different drive modes:

- Tortoise mode (2)
- Hare mode (3)
- Blue Q mode (4)

The icon of the drive mode selected appears on the display.

- Select the desired drive mode using the navigation keys

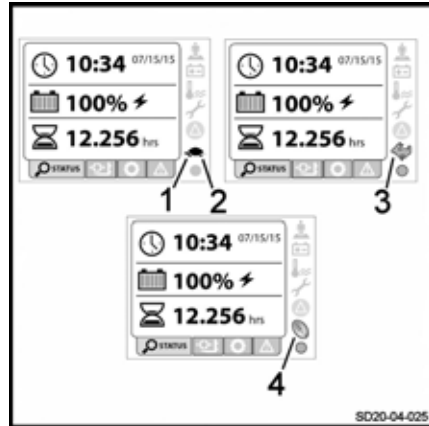

Activity indicator

The **activity indicator** light (1) flashes continuously while the truck is in operation.

When the indicator is off, the display unit is locked or frozen. A warning is shown on the display.



Settings menu

It is possible to access different settings through the Settings menu.

- Select the **Settings** menu (1)

This menu allows access to a drop-down menu (2) consisting of:

- Language
 - Unit
 - Date format
 - Date
 - Time
 - Adjustment of the Load Management warning sounds
 - Adjustment of the contrast
 - Adjustment of the brightness
- Select the desired option

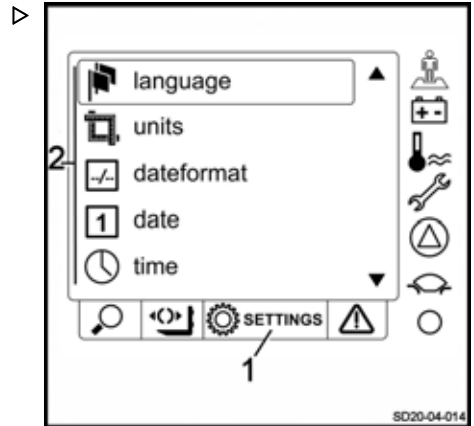

Error codes menu

It is possible to access error messages that are disrupting the operation of the truck.

- Select the **Error messages** menu (1)

The operator can access the error codes. If several codes are affecting the truck, the operator can scroll through several successive displays.

The number of error messages is indicated at the bottom of the display (2).

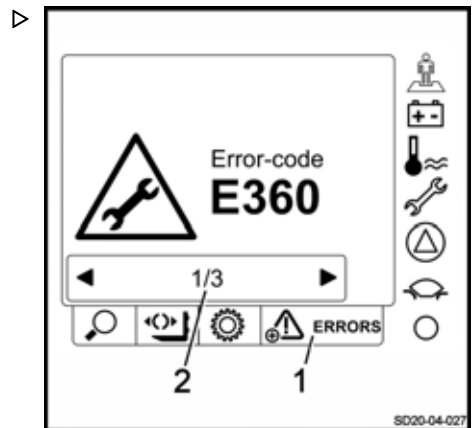

Using the display-operating unit

Start-up screen

In addition to the various menus and lights mentioned above, additional data is available:

- The **Truck status** menu (1) displays the truck menu
- The **hourglass** icon (2) indicates the operating time of the truck
- The **clock** icon (3) indicates the time and date

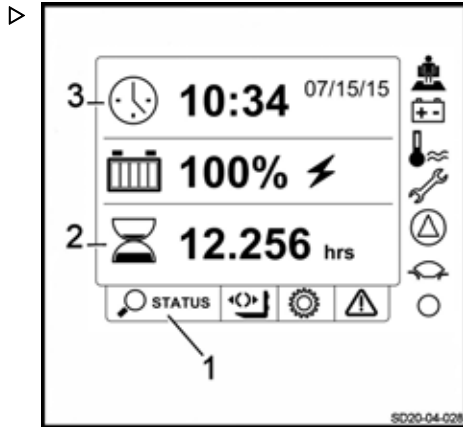

Driving safety guidelines

Behaviour when driving

Operators must obey the same rules within the plant as on the road. They must drive at speeds appropriate for the driving conditions.

Therefore, they must drive slowly:

- When cornering
- Through narrow passageways
- Through swing doors
- In low-visibility areas
- When the roadway is uneven

Operators must always maintain a safe braking distance from vehicles or people in front of them. They must always maintain control of the truck. They must avoid sudden stops, making fast U-turns, overtaking other vehicles in potentially hazardous or low-visibility areas.

Driving the truck while sitting on the dashboard is prohibited. The operator must be resting against the seat.

These trucks are designed to be used as a pallet stacker, double pallet stacker and pallet truck. Therefore:

- Never sit on the dashboard to drive the truck
- The truck must not be used as a stepladder
- The truck is not designed to transport people
- Operators must always stay within the truck clearance
- Stay in the safety area (working area defined by the manufacturer)
- Ensure the stability of the truck and do not exceed its capacity

Use of a telephone or radio with the truck is permitted.

However, do not use these devices when driving as they may distract you.

Take a test drive on an open surface.



NOTE

Drivers must wear safety shoes that fit properly to be able to drive and brake in complete safety.

Driving

Driving

Defining directions

Names used in the text refer to the component installation position with respect to the driver's compartment.

- Reverse travel (1)
- Forward travel (3)
- To the right (4)
- To the left (2)

The load is positioned at the rear.

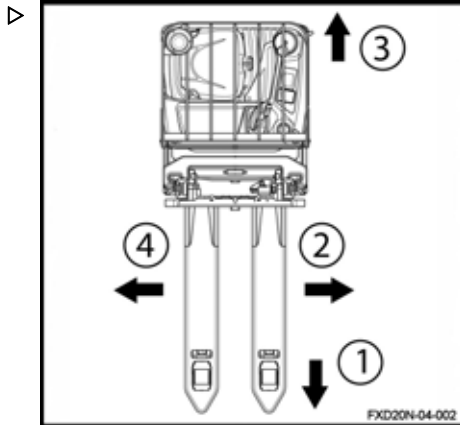

Driving

⚠ WARNING

Be aware of the position of the drive wheel

Slowly start the truck.

Check the position of the drive wheel on the display.



NOTE

Always operate the drive switch slowly, as the truck reacts immediately. Abrupt starts, braking or reversal of drive direction must be avoided at all costs.

The drive switch is located on the control unit.



NOTE

Always keep hands and feet inside the driver's compartment while the truck is moving.

Forward travel

- Using your thumb, push the drive switch to the left (2) to travel forwards (opposite fork direction).
- When the drive switch is released, the truck brakes electrically.

Reverse travel

- Using your thumb, push the drive switch to the right (1) to travel backwards (fork direction).
- When the drive switch is released, the truck brakes electrically.

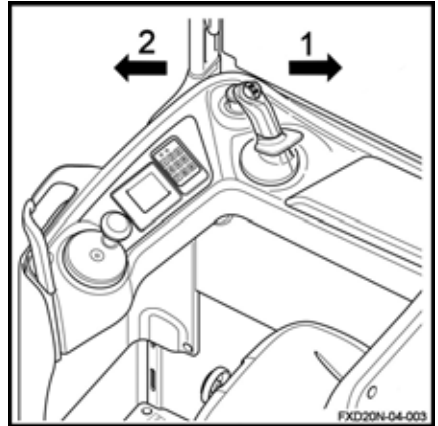

WARNING

Restricted visibility

During reverse travel, visibility may be restricted. Be very careful. Make sure that the path behind is clear before travelling backwards.

Reversing the drive direction

- Push the drive switch in direction (1) or (2).
- Release the drive switch.
- Operate it progressively in the opposite direction until the required speed is reached.

Braking

WARNING

The quality of the floor surface affects the braking distance of the truck.

This should be taken into consideration when driving.

Driving

Braking by reversing the drive direction ▷

- Move the drive direction switches (2) or (3) in the opposite drive direction.

Braking by releasing the drive switch

- While travelling, completely release the drive switch.

The brake is automatically activated. The truck is immobilised.

Electromagnetic braking

The electromagnetic brake is activated automatically if one of the following conditions is met:

- The operator releases the operator presence pedal (decelerates and then brakes)
- The operator gets up from the seat (decelerates and then brakes)
- The drive switch is in the neutral position
- The power supply is cut off
- The operator presses the emergency off switch

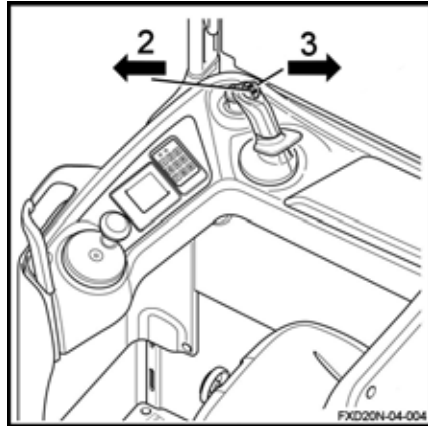

Horn

The horn is positioned on the rear side of the control module.

It is used:

- On routes where there is poor visibility
 - At junctions
 - In the event of immediate danger
- Press the button (1) on the control module.

The horn sounds.

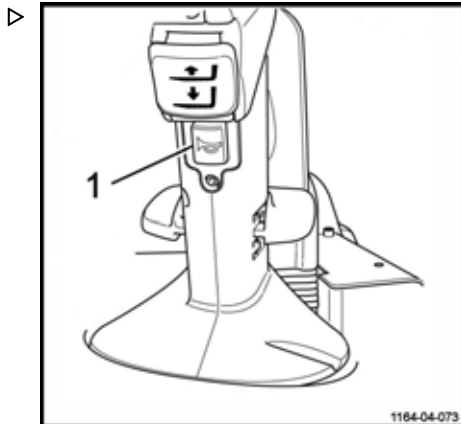

Drive program

The indicator light (1) is on during operation of the truck. The shape of the indicator light indicates the selected program.

The truck is equipped with three different drive programs:

- Hare mode (3)
- BlueQ mode (4)
- Tortoise mode (2)

NOTE

When the operator restarts the truck, the last mode selected is automatically activated.

NOTE

The drive program is instantly changed. If the operator changes mode while driving the truck, he must remain vigilant.

Hare mode

When Hare mode is selected on the screen, the truck operates at its maximum performance.

Blue Q mode

Selecting Blue Q mode allows you to slightly reduce the performance of the truck:

- The travel speed of the truck is reduced (70% of maximum speed)
- The speed of lifting and lowering the forks is reduced (90% of maximum speed)

This mode allows you to save battery.

Tortoise mode

Selecting Tortoise mode allows you to reduce the performance of the truck:

- The travel speed of the truck is reduced to 6 km/h
- The speed of lifting and lowering the forks is considerably reduced

The different speeds can be adjusted. Contact the After-Sales Service Centre to change these.

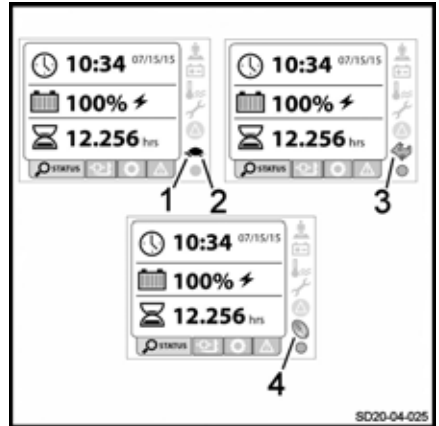

Driving

Joystick function (option)

The truck may be equipped with a joystick in place of the control unit.

The operation is therefore different.



NOTE

Always operate the joystick slowly, as the truck reacts immediately. Abrupt starts, braking or reversal of drive direction must be avoided at all costs.

Front of the joystick

The front of the joystick is used to:

- Move the truck forwards or backwards
- Raise or lower the forks

Forward travel

- Push the joystick to the left (1) to travel forwards (opposite fork direction).

Reverse travel

- Push the joystick to the right (2) to travel backwards (fork direction).

Fork lifting

- Tilt the joystick downwards (4)

Fork lowering

- Tilt the joystick to upwards (3)

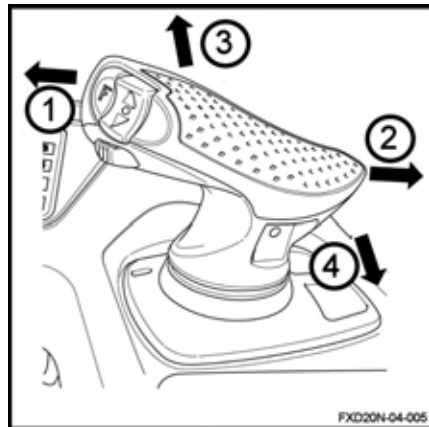

Rear of the joystick

The rear of the joystick is used to:

- Sound the horn
- Raise or lower the load arms

Horn

- Press the button (5) on the joystick.

Raising the load arms (initial lift)

- Press the button (6) on the joystick.

Lowering the load arms (initial lift)

- Press the button (7) on the joystick.

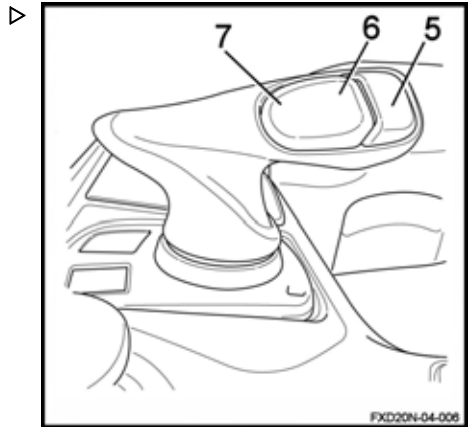

Steering Knob option

The Steering Knob device can replace the steering wheel controls.

⚠ WARNING

Risk of sharp truck movement

The Steering Knob device is highly sensitive. It is important to handle the turning knob with caution.

The turning knob allows you to adjust the position of the wheel. There is no need to reposition it when driving if the trajectory is straight.

When the button is positioned in the centre at the zero point (1), the truck travels in a straight line.

Two stops, one on the left (2) and one on the right (3), delimit the axis of rotation. The operator adjusts the turning knob within this axis to drive.

In forward travel (opposite direction to the forks)

- Move the turning knob to the left (anti-clockwise) (2) to turn to the left
- Move the turning knob to the right (clockwise) (2) to turn to the right

In reverse travel (fork direction)

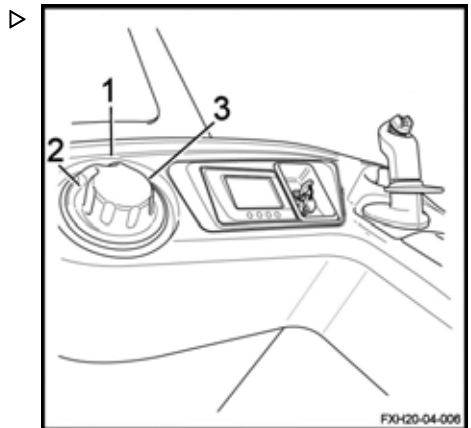

Driving

- Move the turning knob to the left (anti-clockwise) (2) to turn to the right
- Move the turning knob to the right (clockwise) (2) to turn to the left

Using the truck on a slope

NOTE

Incorrect use of the truck on a slope is not recommended. It places particular stress on the traction motor, brakes and battery.

Slopes must be approached with great caution:

- Never attempt a slope whose gradient is greater than that specified in the truck's datasheet.
- Make sure that the ground is clean and has a non-slip surface and that the route is clear.

Travelling up slopes

Always travel up slopes in reverse. The load faces uphill.

Without a load, we recommend that you go up a slope forwards.

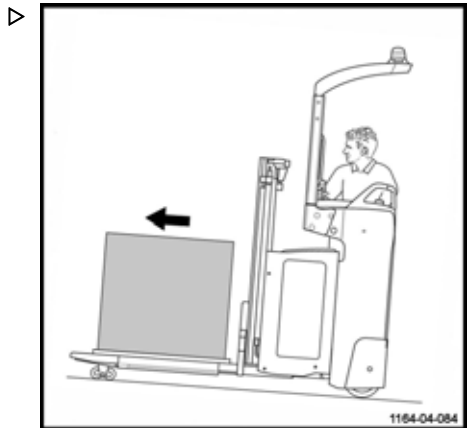

Driving

Travelling down slopes

Always travel down slopes forwards. The load faces uphill.

Without a load, we recommend that you descend a slope forwards.

In all cases, you must travel at a very low speed and brake gradually.

⚠ DANGER

Danger of death and/or risk of serious damage to equipment

Never park the truck on a slope. Never make a U-turn or take shortcuts on a slope.

On a slope, the operator must drive more slowly.

⚠ WARNING

Risk of serious injury and/or serious damage to equipment

Driving on slopes steeper than 10% is prohibited due to braking capacity and stability. The load being transported could tip over.

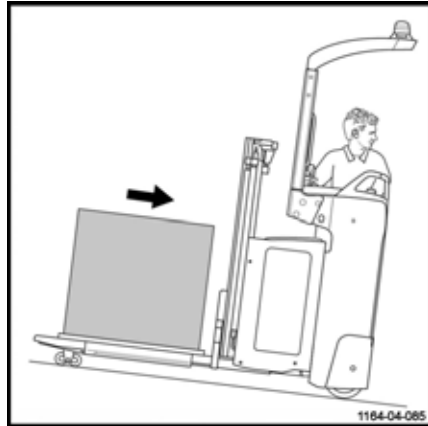

Starting on a slope

Proceed as follows:

- Move the drive switch in the required direction.
- Release the drive switch to apply the parking brake.

Operating the FleetManager™ option

Description of the FleetManager option

The FleetManager option allows you to control access to the truck. The option is a fleet management system.

You can access the system:

- Either by using a keypad
- Or by using a reading device for a transponder or an RFID card

The fleet manager sets the access details via the web interface. This affects the transponder cards or PIN codes for the corresponding trucks. It is possible to change the amount of time for which the access authorisation is valid.

Software is also available.

Additional options:

- Shock sensor
- Tools for wireless data management:
 - ▶ GSM⁽²⁾GPRS⁽¹⁾ module with antenna

The options available on the truck are:

- Access control
- Access control and shock sensor
- Access control and GPRS module
- Access control, shock sensor and GPRS module

⁽¹⁾ GPRS: General Packet Radio Service

⁽²⁾ GSM: Global System for Mobile Communication

Shock sensor

This sensor allows you to record the shocks received by the truck.

If the truck receives a shock, it is possible to configure a speed reduction.

The fleet manager is the only person who is able to change certain parameters.



NOTE

Replace the sensor if it is faulty.

GSMGPRS module

The module consists of a GSM modem and an antenna.

The module allows you to:

- Access truck information remotely
- Use geolocation

The data is stored on a server.

Data is transmitted by Bluetooth (default) or by GSM module (optional).

Operating the FleetManager™ option

Commissioning a truck equipped with the FleetManager™ option

Commissioning a truck equipped with a keypad or an electronic key ▷

- Turn the switch key to start the truck.
- Enter the PIN code on the keypad. The PIN code consists of five to eight digits.

By default, no PIN code is given as a factory setting.

If the PIN code is correct, the LED (1) is not lit. The LED (2) flashes slowly at two-second intervals (green colour).

No acoustic signal sounds.

- Press the Enter key (3) to confirm.

The truck is now ready for use.

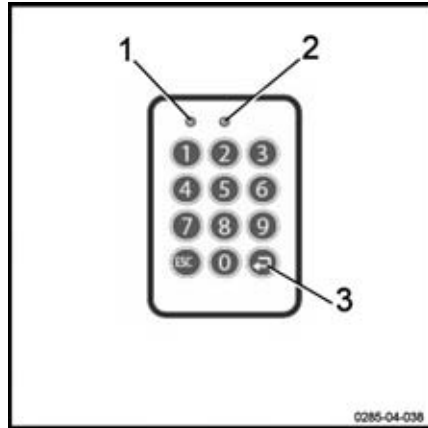

NOTE

In the configuration, the fleet manager can specify that the operator must enter a preliminary code when logging in. The operator can then assess the state of the truck.

Commissioning a truck equipped with an RFID reading device ▷

- Turn the switch key to start the truck.
- Place the RFID transponder card or the RFID transponder (4) in front of the reading device (3).

If the card is correct, the LED (1) is not lit. The LED (2) flashes slowly at two-second intervals (green colour).

Two acoustic signals sound.

The truck is now ready for use.

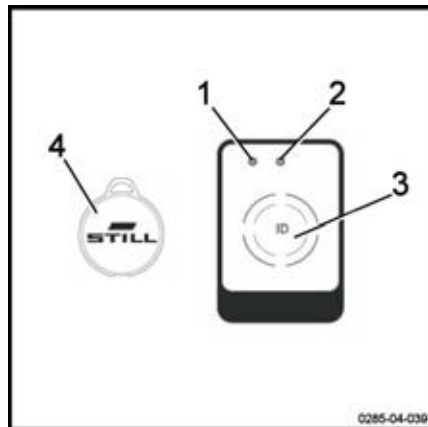

FleetManager™ option: Colour code for the LEDs

The LEDs can have different statuses and different colours. Below is the list of the most common messages and their meanings.

Malfunction		Signal transmitter	Cause	Solution
LED status				
LED 1	LED 2			
Lit continuously Red colour	Off	A long acoustic signal sounds	Reading device variant: no valid access authorisation	Generate a valid access authorisation using the interface
			Keypad variant: no valid access authorisation for the PIN code entered	
Lit continuously Red colour	Flashes once Green colour	A long acoustic signal sounds	Keypad variant: PIN code entered incorrect or not confirmed using the Enter key	Re-enter the PIN code
			The operator has been granted access authorisation. But the period of validity has expired.	Use the interface to enter a new period of validity
Flashes quickly Yellow colour	Lit continuously Green colour		The date of the truck is incorrect	Update the date of the truck
Flashes quickly Red colour	Lit continuously Green colour		Memory is 80% full	Clear the memory
Flashes quickly Red colour	Flashes quickly Red colour	A long acoustic signal sounds upon activation	There are several possible causes: - Reading device or keypad not accessible - GPRS module not accessible - Built-in rechargeable battery flat - Memory full	Contact the After-Sales Service Centre

Operating the FleetManager™ option

Malfunction		Signal transmitter	Cause	Solution
LED status				
LED 1	LED 2			
Flashes quickly Red colour	Lit continuously Green colour		A shock has occurred	Reset the shock
Flashes quickly Blue colour	Off		The truck is connected via a Bluetooth link. The operating data is being read. The reading process can take up to five minutes.	The truck is switched on but is not moving. Wait for all of the relevant data to be read. As soon as the LEDs change to a different status, resume work.

Disconnecting a truck equipped with the FleetManager™ option

NOTE

Operators must not log off intentionally while driving.

WARNING

Access to the truck must be disabled.
Unauthorised users are not allowed to use the truck.

Disconnecting a truck equipped with a keypad or electronic key ▷

- Park the truck in a safe place.
- Press the button (3) to log off. Keep the button pressed in.

No LEDs light up. A long acoustic signal sounds.

The LED (1) lights up for a second (red colour). The LED (2) is not lit. A long acoustic signal sounds.

The LED (1) is no longer lit. The LED (2) flashes slowly at two-second intervals (green colour). No acoustic signal sounds.

The truck is disabled.

- Turn the switch key to the off position to switch the truck off completely.

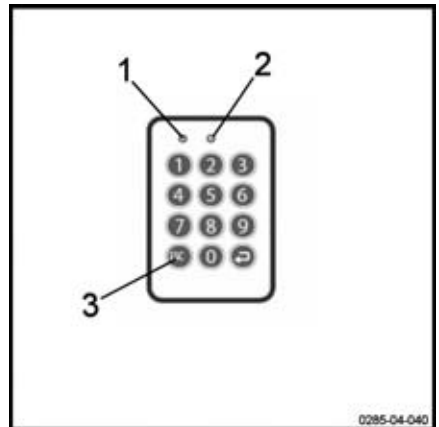

Operating the FleetManager™ option

Disconnecting a truck equipped with an RFID reading device ▶

- Park the truck in a safe place.
- Briefly place the RFID card or the RFID transponder (4) in front of the reading device (3).

The LED (1) lights up for a second (red colour). The LED (2) is not lit. A long acoustic signal sounds.

The LED (1) is no longer lit. The LED (2) flashes slowly at two-second intervals (green colour). No acoustic signal sounds.

The truck is disabled.

- Turn the switch key to the off position to switch the truck off completely.

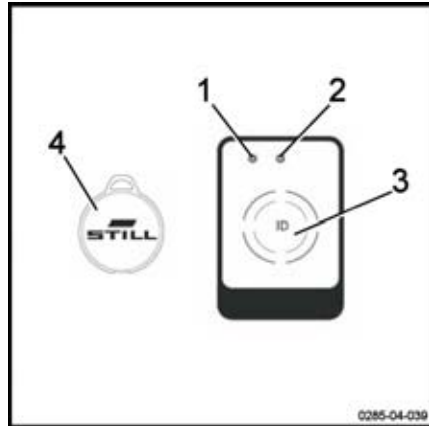

Transporting loads

Load handling safety rules

⚠ WARNING

Carefully observe the following instructions before picking up loads. Never touch or stand on moving parts of the truck (e.g. lifting device, pushing devices, work installations or devices for picking up loads).

⚠ WARNING

Take care not to trap hands or feet when operating the truck.



Grabbing a loading unit

Watch out for the following elements:

- the load must be well-balanced and centred correctly between the fork arms
- the fork arms must be sufficiently slid underneath the load to guarantee stability.

The load must not protrude too far over the fork arms, nor should the fork arms protrude too far out from the load.

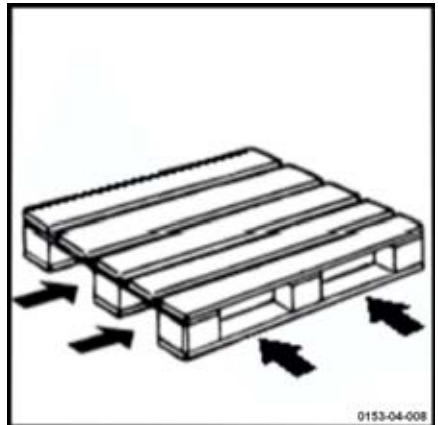

Transporting loads

Transporting pallets or other containers ▷

As a general rule, loading units must be transported one by one (e.g. pallets). Transporting several loading units at a time is only authorised:

- when the safety preconditions are fulfilled.
- by order of the monitoring agent.

The forklift operator must ensure that the loading unit is properly packaged. He must only move loading units that have been carefully prepared and that meet the safety requirements.

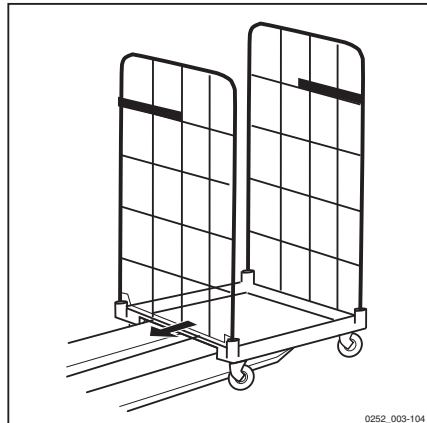
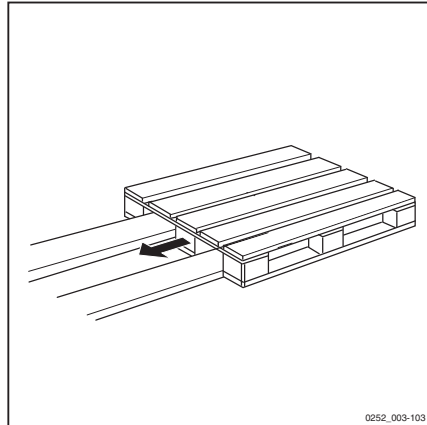

Lift control elements

⚠ WARNING

Risk of injury

The safety instructions must be strictly adhered to.

Do not touch or stand on moving parts (e.g. lifting device, pushing devices, work installations, load lifting devices).

⚠ CAUTION

Risk of the load swinging and loss of stability

Do not drive with a load in the raised position without load on the load arms. The high load must be lowered as close as possible to the load in the low position. The forklift operator must lower the forks again before moving the truck.

The truck has two lift systems:

Main lift

Lifting the fork arms

- Start the truck.
- Push the fork lifting control (1) upwards (A).

The fork arms are raised.

Lowering the fork arms

- Pull the fork lowering control (1) downwards (B).

The fork arms are lowered.

When the lifting control (1) is released, the forks stabilise at the required height.

i NOTE

The speed of lifting and lowering movements is determined by the degree to which the control (1) is moved. It automatically returns to neutral position when it is released.

⚠ CAUTION

Lifting and lowering the forks

Always use this control (1) gently without jerking.

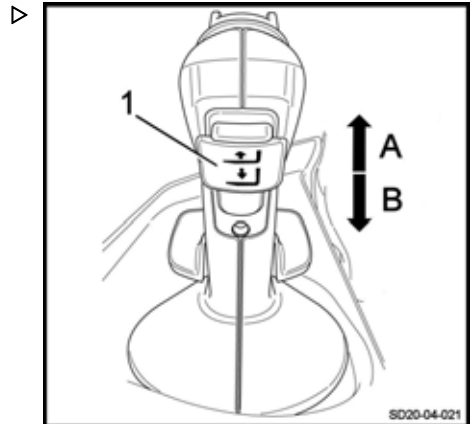

Transporting loads

Base lift

Lifting the load arms

- Pull the control (2) downwards (D).

The load arms are raised.

Lowering the load arms

- Push the control (2) upwards (C).

The load arms are lowered.

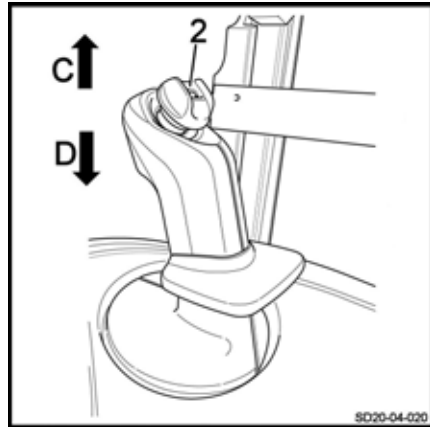

Reading the capacity plate

⚠ CAUTION

Risk of loss of control

Before picking up a load, make sure that its weight does not exceed the lifting capacity of the machine.

Refer to the nominal capacity specified on the truck's capacity plate (1).

The values shown correspond to compact, homogeneous loads. They must not be exceeded. If they are exceeded, the stability of the truck and the resistance of the mast and the chassis are no longer guaranteed.

The distance of the load centre of gravity from the back of the fork and the lift height determine the maximum load weight. Check that the pallet is in good condition.

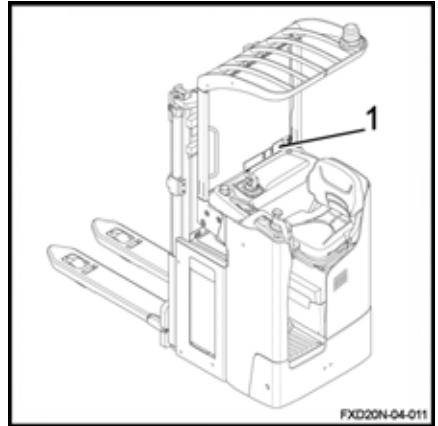

FXV 14/16 N capacity — without initial lift

FXV 14 N: 1400 kg

FXV 16 N: 1600 kg

FXV 14/16 N capacity — with initial lift

FXV 14 N: 1400 kg

FXV 16 N: 1600 kg

Usage in pallet truck mode: 2000 kg at a height of 210 mm.

Reading the capacity plate

Example using an FXV 16 N with initial lift, fitted with a 4716-mm triplex mast:

- 1: Maximum lift height: 4802 mm
- 2: Maximum mast capacity: 820 kg with a height of 4802 mm (centre of gravity: 400 mm)
- 3: Maximum mast capacity: 820 kg with a height of 4802 mm (centre of gravity: 500 mm)
- 4: Maximum mast capacity: 820 kg with a height of 4802 mm (centre of gravity: 600 mm)
- 5: Lift height: 3000 mm
- 6: Mast capacity: 1600 kg with a height of 3000 mm (centre of gravity: 400 mm)
- 7: Mast capacity: 1600 kg with a height of 3000 mm (centre of gravity: 500 mm)

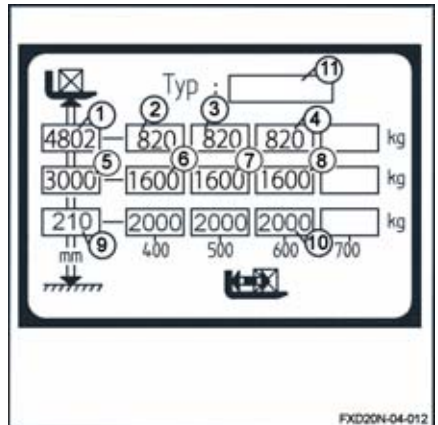

Transporting loads

- 8: Mast capacity: 1600 kg with a height of 3000 mm (centre of gravity: 600 mm)
- 9: Maximum lift height: 210 mm with 2000 kg in pallet truck mode
- 10: Maximum capacity in pallet truck mode: 2000 kg with a height of 210 mm
- 11: Model

Progressive stopping of the carriage ▷ in the lower position

A detector (1) that senses when the position of the forks is 30 cm from the bottom part of the mast triggers an automatic slowing of the lowering action. This detector prevents a violent impact at the end of travel.

- Push the fork lowering control until the carriage is fully lowered.

The progressive shutoff device for the carriage prevents the buffer from being hit at the end of travel.

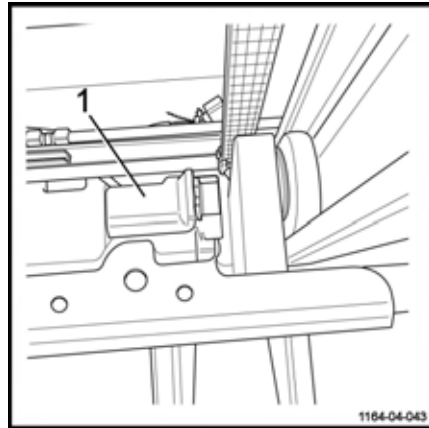

Handling a single load

⚠ DANGER

Risk of truck falling

Do not stack the initial lift high.

Before picking up a load

Ensure that the load weight does not exceed the capacity of the truck.

- Refer to the nominal capacity specified on the truck's capacity label
- You must also make sure that the load is stable, well-balanced, attached firmly and centred between the fork arms in order to avoid dropping any part of the load
- Check that the width of the load is compatible with the width of the fork arms
- Check that the load is not damaged

⚠ CAUTION

Risk of injury

Safety shoes must be worn.

Transporting people is strictly prohibited. Do not use the forks to lift a person.

⚠ DANGER

Risk of tipping

It is essential to slow down when approaching a corner or on wet ground.

⚠ CAUTION

Arrangement of loads

Do not touch nearby loads or loads positioned at the side or in front of the load being handled.

Arrange the loads with a small space between them to prevent them hooking onto one another.

⚠ DANGER

Risk of crushing fingers, hands and arms

Do not put your hands above the mast protection. Do not disassemble the mast protection.

Transporting loads

Picking up a load from the ground

- Use the initial lift to raise a load of up to 2000 kg several centimetres from the ground.

Transporting a load

⚠ DANGER

Risk of accident

There must be no one under or near the truck when the load is in the raised position.

⚠ DANGER

Risk of falling

Never transport a load with the forks in the raised position as the truck may become unstable.

Observe the following recommendations:

- Drive forwards for optimum visibility
- Travel up or down slopes with the load up-hill Do not travel across the slope or make a U-turn
- Reverse travel is used for setting down the load Adjust your speed, as the position of the forklift operator is now less comfortable
- Do not drive with an unstable load
- If visibility is poor, let someone guide you
- Raise the forks slightly in order to pass obstacles
- Be careful of low passageways, low doorways, scaffolding, pipes etc.
- Check that the width of the load is not greater than the width of the aisle

Setting a load down on the ground

Proceed as follows:

- Drive the truck to the required location.
- Carefully move the load into the unloading zone.
- Lower the load until the forks are free.
- Withdraw the truck in a straight line.
- Raise the forks a few centimetres.

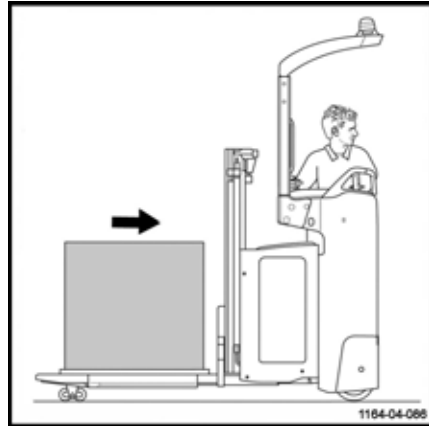

⚠ CAUTION

Risk of falling

Do not touch nearby loads or loads positioned behind the truck.

⚠ CAUTION

Risk of accident

Before you set down the load, ensure that no one is around the truck or the load.

Stacking a load**⚠ DANGER**

Risk of loss of stability

In order to retain maximum stability and to avoid any risk of overloading the truck, do not use the initial lift control to disengage the load from the storage area.

Proceed as follows:

- Drive the truck to the required location.
- Lower the load arms completely.
- Raise the forks clearly above the level where the load is to be placed.
- Drive the truck forward into the rack.
- Lower the load until the forks are free.
- Withdraw the truck in a straight line.
- Lower the forks again until they are several centimetres from the ground.

⚠ DANGER

Risk of fatal accident

There must be no one under or near the truck when the load is in the raised position.

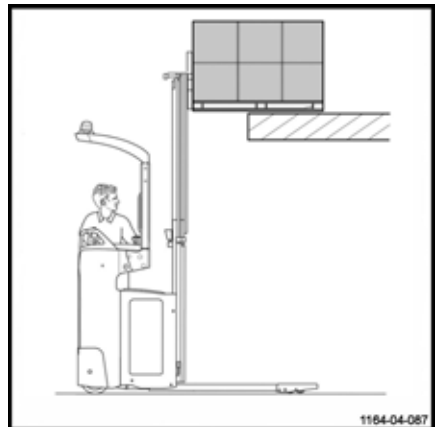

Transporting loads

Picking up a load at a height

Proceed as follows:

- Drive the truck to the required location.
- Lower the load arms completely.
- Lift the forks to the height of the pallet.
- Carefully move the forks forward under the pallet.
- Lift the forks until the pallet is lifted free of the rack.
- Move slowly to withdraw the forks from the rack.

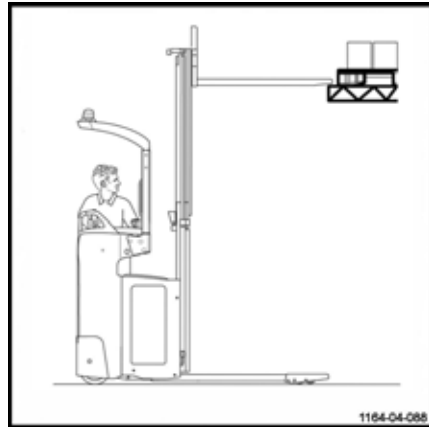

▲ DANGER

Risk of hooking the mast on the rack

Do not start lowering the forks until they are completely clear of the rack. The forklift operator must remain vigilant and ensure that there are no obstacles preventing the lowering of the forks.

- With the load on the forks, lower the forks again until they reach the ground.
- Lift the load arms to move the truck.

Before leaving the truck



NOTE

Always stop the truck on level ground away from traffic routes.

Proceed as follows:

- Lower the forks to the lowered position.
- Switch off the ignition (key or electronic key).
- In the event of a prolonged shutdown, press the emergency off switch. Then disconnect the battery.

Driving assistance system: Dynamic Load Control

Description of the Dynamic Load Control (DLC) ▷

The Dynamic Load Control function (DLC) is a system that assists when driving and using the truck.

The forklift operator must remain vigilant under all circumstances and adhere to the truck capacity plate.

The weight shown on the display has a tolerance of ± 50 kg in static mode.

The Load tab allows you to view the information relating to the Dynamic Load Control option. This option exists in versions of varying complexity.



⚠ CAUTION

Risk of accident

Despite this function, the operator must remain vigilant. The safety guidelines must be observed.

This function enables you to manage the residual capacity of the truck.

On this truck, three different types of DLC are available:

- No DLC
- DLC 1
- DLC 3

The No DLC and DLC 1 versions use the mast sensor between 300 mm and 1500 mm.

The DLC 3 version uses an ultrasonic height sensor. This sensor consists of two distinct components:

- An A unit, called the slave unit (1), located on the fork carriage
- A B unit, called the master unit (2), located on the chassis

These two components communicate with one another by ultrasound.

Driving assistance system: Dynamic Load Control

⚠ CAUTION

Risk of loss of warranty.

The A unit (1) contains a battery. Only a technician approved by the After Sales Service Centre may change this battery. It is normally changed every two years or after 2000 hours of operation.

⚠ CAUTION

Risk of incorrect use of the truck.

The operator must be trained on and familiar with the various features of this function.

The No Dynamic Load Control (DLC) display

The No DLC display (1) may appear on the truck display with the DLC1 option.

When the DLC is not active, the message does not appear on the display. In a configuration without DLC, nothing is displayed.

It appears when the forks are lifted beyond 1500 millimetres. Simply lower the forks again to restore the Dynamic Load Control function.

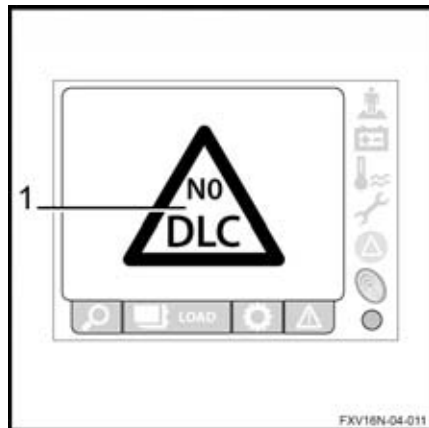

The initial lift must be in the lowered position to be able to raise the forks above 1500 mm. If the initial lift is lifted, the main lift is blocked at 1500 mm. The following screen (2) appears on the display until the initial lift is lowered completely.



⚠ CAUTION

Risk of incorrect use of the truck

The forklift operator must be trained in the use of this option and remain vigilant.

Using Dynamic Load Control (DLC) version 1

The Dynamic Load Control (DLC) option version 1 informs the forklift operator of:

- The maximum weight allowed on the forks (nominal load) when the maximum value is close or has been exceeded. At all other times, the maximum weight allowed on the forks is not displayed
- The weight present on the forks

⚠ WARNING

There is a risk of striking a rack or a load

The display values on the screen (load) are provided for information only. Due to the tolerance range, the values cannot be used for precision operations.

The operator must visually check that the forks are at the correct height when handling loads in a rack.

Example of reading a display with the Dynamic Load Control (DLC) option version 1:

The weight of the load on the forks (2) is not displayed.

The maximum authorised load is 1400 kg (1).

i NOTE

It may be necessary to update the weight. This is done automatically by the software. The display then shows "Weight update".

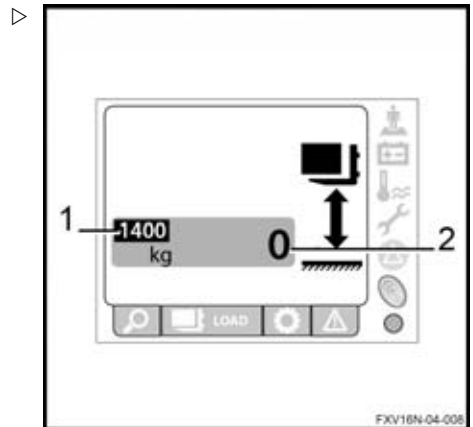

Driving assistance system: Dynamic Load Control

Example of reading a display with the Dynamic Load Control (DLC) option version 1: load weight close to maximum values

The weight of the load on the forks is 2000 kg (2). A tolerance of ± 50 kg applies. The displayed weight takes this into account.

The maximum authorised load (1) on the forks is 2000 kg.

The measured weight is the maximum weight. A warning beep sounds once and a yellow triangle symbol (3) is shown on the display. The measured weight (2) flashes.

An arrow indicates whether it is possible to continue raising or lowering the forks. The beep indicates that the weight is approaching the maximum weight.

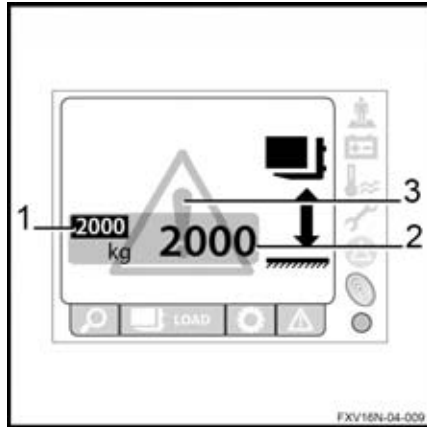

Example of reading a display with the Dynamic Load Control (DLC) option version 1: weight of the load significantly exceeded

The weight of the load on the forks is 1600 kg (3). A tolerance of ± 50 kg applies. The displayed weight takes this into account.

The maximum authorised load (1) on the forks is 1400 kg.

The measured weight exceeds the maximum weight. Warning beeps sound and a red triangle symbol (2) is shown on the display. The measured weight (3) flashes.

The arrow points downwards only.

The operator must lower the forks immediately. The symbol disappears and the beeps stop.

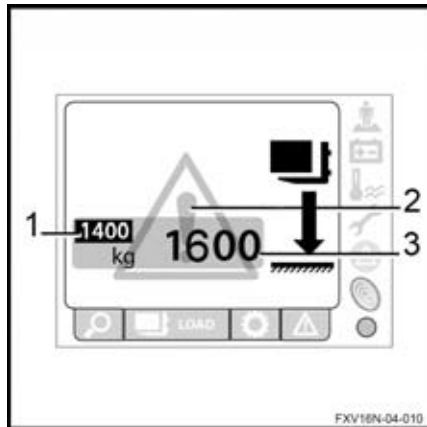

⚠️ WARNING

Risk of loss of stability

While driving the truck, the operator must not listen to an MP3 player or any other device that could impair awareness of his/her working environment. He/she also must be very vigilant in case of loud ambient noise. He/she might not hear the warning beeps.

Using Dynamic Load Control (DLC) version 3

The Dynamic Load Control (DLC) option version 3 allows you to:

- Manage the residual capacity of the truck in relation to the load weight and the mast height
- Adjust the maximum speed of the truck in relation to the load weight and the mast height

The maximum height is always displayed.

This option is not compatible with the Cold Store option.

Managing residual capacity

The Dynamic Load Control (DLC) option version 3 shows height and load values. However, this is only an aid to driving, and the operator must remain vigilant under all circumstances.

WARNING

There is a risk of striking a rack or a load

The values displayed on the screen (height and load) are provided for information only. Due to the tolerance range, the values cannot be used for precision operations.

The operator must visually check that the forks are at the correct height when handling loads in a rack.

Example of reading a display with the Dynamic Load Control (DLC) option version 3:

Driving assistance system: Dynamic Load Control

The weight of the load on the forks (4) is not displayed. ▷

The lift height measured (3) is 2.9 m.

The maximum permitted height is 3.3 m (1) with a maximum load of 1400 kg (2).

NOTE

It may be necessary to update the weight. This is done automatically by the software. The display then shows "Weight update".

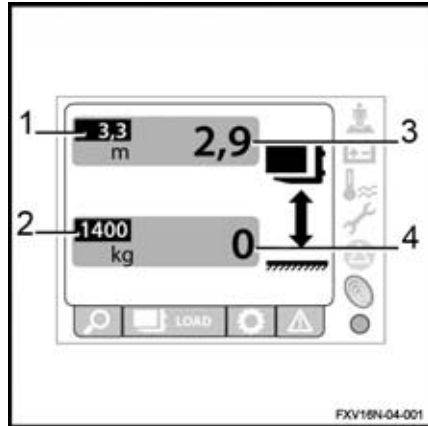

Example of reading a display with the Dynamic Load Control (DLC) option version 3: load weight or lift close to maximum values ▷

The weight of the load on the forks is 1250 kg (6). A tolerance of ± 50 kg applies. The displayed weight takes this into account.

The maximum authorised load (3) on the forks is 1400 kg.

The maximum authorised height (1) is 3.3 m.

The lift height measured (4) is 3.2 m.

The measured weight is close to the maximum weight. The lift height is close to the maximum authorised height. A warning beep sounds once and a yellow triangle symbol (2) is shown on the display. The measured weight and the measured height flash.

An arrow (5) indicates whether it is possible to continue raising or lowering the forks. The beep indicates that the weight and/or the lift are near the maximum.

If the measured weight alone had been close to the maximum value, it would have been the only one to flash.

If the measured height alone had been close to the maximum value, it would have been the only one to flash.

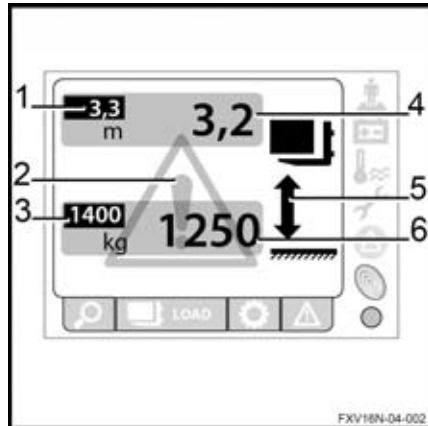

Example of reading a display with the Dynamic Load Control (DLC) option version 3: weight of the load slightly exceeded

The weight of the load on the forks is 1450 kg (6). A tolerance of ± 50 kg applies. The displayed weight takes this into account.

The maximum authorised load (3) on the forks is 1400 kg.

The maximum authorised height (1) is 3.3 m.

The measured lift height (4) is 2.9 m. The weight of load on the forks exceeds the authorised value for this height. The lift height is lower than the maximum authorised height. A warning beep sounds once and a yellow triangle symbol (2) is shown on the display. The measured weight flashes.

The arrow (5) points downwards only.

The operator must lower the forks and the symbol disappears. However, lifting can continue in order to free a load.

There is a similar display when the measured lift is greater than the authorised lift.

Example of reading a display with the Dynamic Load Control (DLC) option version 3: weight of the load significantly exceeded

The weight of the load on the forks is 1600 kg (6). A tolerance of ± 50 kg applies. The displayed weight takes this into account.

The maximum authorised load (3) on the forks is 1400 kg.

The maximum authorised height for the maximum weight (1) is 3.3 m.

The measured lift height (4) is 2.9 m. The load on the forks is too heavy. The lift height is lower than the maximum authorised height. Warning beeps sound and a red triangle symbol (2) is shown on the display. The measured weight flashes.

The arrow (5) points downwards only. Lifting is then blocked.

The operator must lower the forks immediately. The symbol disappears and the beeps stop.

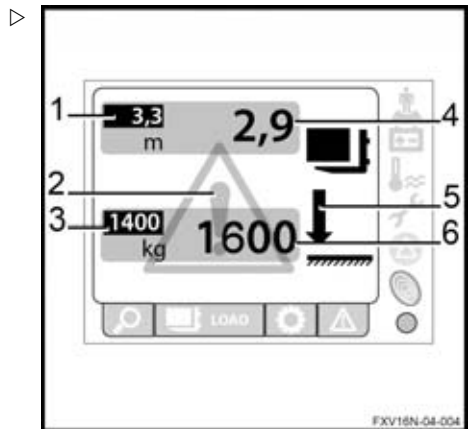
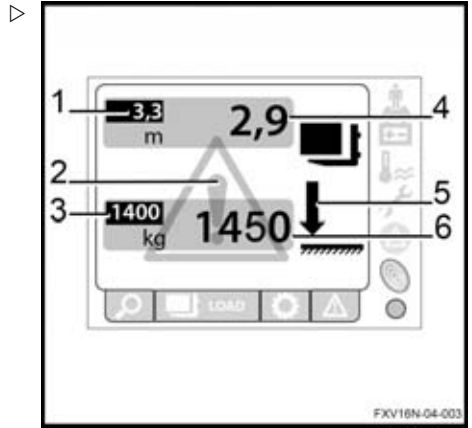

Driving assistance system: Dynamic Load Control

However, the operator can still continue lifting to free a load. To authorise this activity, he must proceed in the following manner:

- Validate the message "Caution." "Capacity exceeded" (1) using the confirmation button (2).

The controller records the confirmation of this message. The beeps continue until the forks are lowered.

There is a similar display when the measured lift is greater than the authorised lift.

⚠ DANGER

Loss of stability

The operator could lose control of the truck stability by continuing the lift despite the warning beeps. The operator is then responsible in case of an accident.

⚠ WARNING

Risk of loss of stability

While driving the truck, the operator must not listen to an MP3 player or any other device that could impair awareness of his/her working environment. He/she also must be very vigilant in case of loud ambient noise. He/she might not hear the warning beeps.

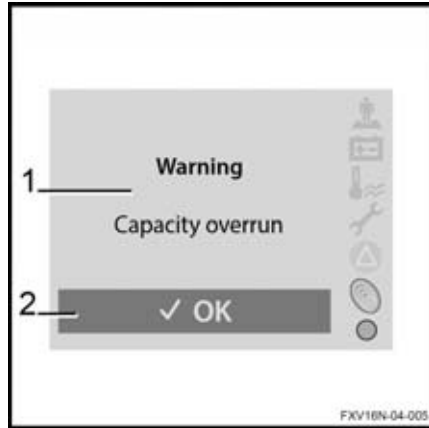

Rules for using the Dynamic Load Control

⚠ WARNING

There is a risk of striking a rack or a load

The values displayed on the screen (height and load) are provided for information only. Due to the tolerance range, the values cannot be used for precision operations.

The operator must visually check that the forks are at the correct height when handling loads in a rack.

Starting the truck

NOTE

When starting the truck, the forks must be in the lowered position.

If the forks are in the raised position when starting the truck, the Dynamic Load Control icon (3) is highlighted.

A yellow triangle symbol (1) appears on the display.

The display indicates that the forks (2) must be lowered. The arrow points downwards.

The mandatory lowering of forks function applies only to the DLC 3.

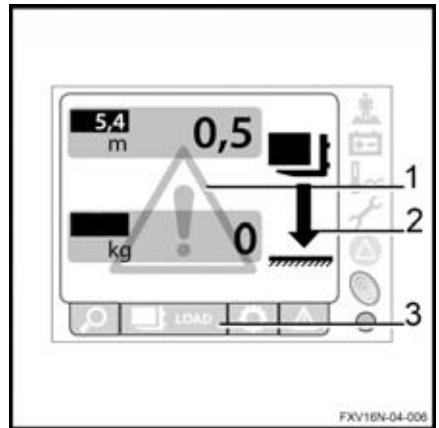

During work

When using the truck, the forks must be lowered regularly.

If the forks remain in the raised position for more than four hours:

- A beep sounds
- The Dynamic Load Control icon (3) appears on the display
- A yellow triangle symbol (1) appears on the display.
- On the display, the arrow (2) points downwards only.
- The forks must be lowered immediately

If the operator does not lower the forks immediately, the truck will only move at 4 km/h and the lifting speed will be reduced.

CAUTION

The display screen no longer works.

Do not continue to operate the truck. Contact the After-Sales Service Centre to change the display.

Driving assistance system: Dynamic Load Control

In the event of error code L354



The error code L354 (1) may appear on the display screen.

It is therefore necessary to check that:

- Nothing is blocking the field between the two sensors. The presence of an object may block it.
- The sensors are clean.

After these checks, the forklift operator must restart the truck.

If the error code L354 appears again after the restart, please contact the After-Sales Service.



Cold store usage (optional)



⚠ CAUTION

Standard trucks risk being subject to significant damage if used in extreme conditions.

Only trucks with the Cold Store option may be used inside cold storage. Specific oil designed for cold stores must be used.

These trucks are identified by their Cold Store label.

Area of Use

Trucks with the Cold Store option may be used in two different areas:

- **operating range 1:** the truck can operate at a temperature of $-5\text{ }^{\circ}\text{C}$ and, for short periods, at a temperature of $-10\text{ }^{\circ}\text{C}$. It must be parked outside of the cold store.
- **operating range 2 (Entry / Exit applications):** the truck must be used alternately inside and outside of the cold store. It can withstand temperatures between $-30\text{ }^{\circ}\text{C}$ and $+45\text{ }^{\circ}\text{C}$. Specific rules should be followed so as not to damage the truck and to avoid the occurrence of streaming (see the following paragraph). The truck is parked outside of the cold store.

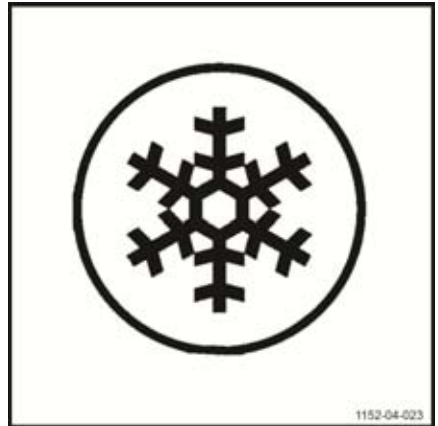

Precautions for Use

The difference in temperature between the cold store and the room temperature zone may result in the formation of condensation water.

This water can freeze when the truck goes back into the cold store and jam the moving parts of the truck.

Streaming occurs if the truck remains outside of the cold store for more than ten minutes. Therefore, it is essential to leave the truck outside of the cold store for 30 minutes so that the condensation disappears.

⚠ DANGER

If the condensation freezes in the cold store, it is prohibited to operate the jammed parts.

This could cause permanent damage to the truck.

Cold store usage (optional)

Parking

The truck must be parked outside of the cold store.

Parking inside the cold store could cause serious damage to the electrical and mechanical equipment (seals, hoses, rubber and synthetic parts).

CAUTION

Do not leave discharged or unused batteries in the cold store.

They could be permanently damaged.

Parking the truck.

WARNING

Risk of injury

Never leave the truck with the load in the raised position.

Do not stop the truck on a slope. If absolutely necessary, secure the truck with wedges.

Stopping the truck

- Immobilise the truck.
- Lower the forks.

- Switch off the ignition (key or electronic key).
- Press the emergency off switch.

Restarting work

- Switch on the ignition again (key or electronic key).
- Press the operator presence pedal.
- Pull the emergency off switch.

Handling the battery

Handling the battery

Battery type

Trucks can be fitted with different types of battery. Comply with the information indicated on your battery's type plate, as well as with its features.

WARNING

The weight and size of the battery influence the stability of the truck.

The new battery must weigh the same as the old one. Do not remove extra weight or change its position.

CAUTION

Be careful not to damage any wiring when replacing the battery.

Order picking

Maintenance personnel

The battery must be replaced by specially trained personnel. Personnel must follow the manufacturer's instructions for the battery, the charger and the truck.

It is also necessary to follow the battery maintenance instructions.

Fire protection measures



WARNING

Do not smoke or create a flame when handling batteries. There must be no combustible material or tools that produce sparks within a minimum radius of 2 m around the truck and the battery charger.

The work area must be well ventilated. Fire extinguishers must be provided and located near the work area.

Parking the truck securely

When the battery is being worked on, the truck must be parked safely. The truck can only be restarted when the covers and connectors have been put back in the operating position.

Opening and closing the battery hood

Opening the battery hood

To open the battery hood:

- Immobilise the truck.
- Lower the forks.
- Switch off the ignition (key or electronic key).
- Press the emergency off switch.
- Lift the hood (1) using the handle designed for this purpose.

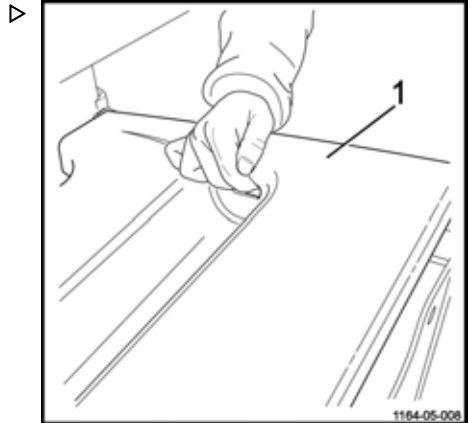

Closing the battery hood

To close the battery hood:

⚠ WARNING

Risk of trapping fingers

When closing the battery hood, correctly position your fingers to avoid any risk of them being trapped.

- Close the hood (1).
- Ensure that the battery hood is closed securely.

⚠ CAUTION

Risk of sparks

Never drive with the hood open or incorrectly closed.

Handling the battery

Charging the battery using an external charger

⚠ CAUTION

Deep discharging may damage the battery.

- Charge the battery immediately.
-
- Park the truck safely.
 - Before charging, check the condition of the battery cable and the charger cable. Replace them if necessary.
 - Open the hood and leave open.
 - Remove the battery handle connector (1) from the truck plug (2).
 - Connect the battery connector to the wall-mounted connector.

⚠ WARNING

Electrical risk

Only unplug the battery connector from the battery charger when both the battery charger and truck are switched off.



NOTE

Follow the instructions provided by the battery and battery charger manufacturers (equalising charge).

⚠ WARNING

Risk of damage, short circuit or explosion.

Do not place any metallic objects or tools on the battery.

Smoking is prohibited.

⚠ WARNING

The electrolyte (diluted sulphuric acid) is toxic and very caustic.

Follow the safety regulations when handling battery acid.

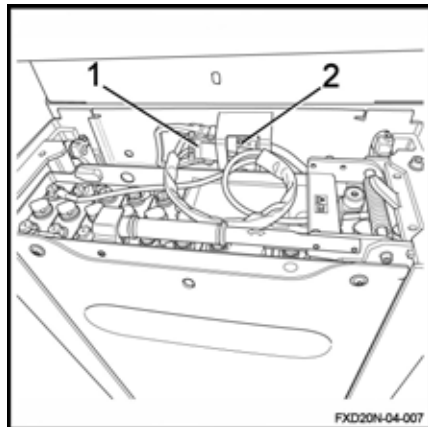

⚠ WARNING

Explosive gases are generated during battery charging.

- Make sure that the area is well-ventilated.
 - Make sure that the battery hood remains open for the entire time the battery is charging.
-

Handling the battery

Changing the side access battery

⚠ DANGER

Risk of trapping fingers

It is advisable to wear gloves when changing the battery.

⚠ WARNING

Risk of injury

Safety shoes must be worn when changing the battery.

Before handling, ensure that there is nobody around the truck.

To remove the battery, we recommend that you use a fixed roller frame or a truck with extraction rollers (fitted with rollers) for easier handling of the battery.

To change the battery, proceed as follows:

- Immobilise the truck
- Lower the forks.
- Switch off the ignition and remove the key.
- Press in the emergency off switch.
- Open the battery hood.
- Unclip the hood from the fixed screw (1). Place it on the forks.
- Disconnect the battery connector located under the dashboard.



- Place the connector on the battery cells.
- Position the truck with extraction rollers or the roller frame (4) in the upright position next to the battery compartment on level ground.

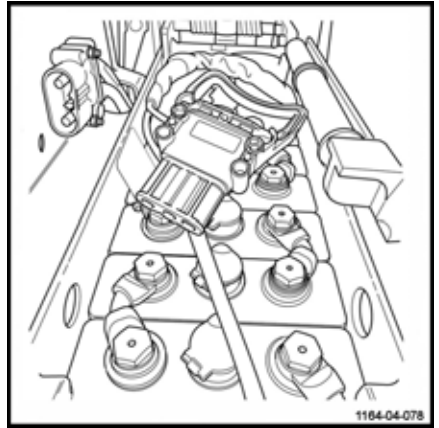

- Operate and pull the locking handle (2) in the direction indicated by the arrow.

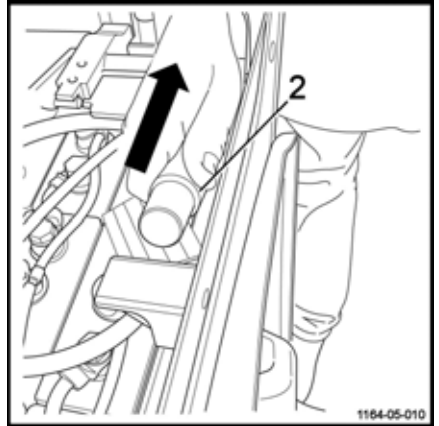

Handling the battery

- Lift the locking bar (3) until the battery is freed.

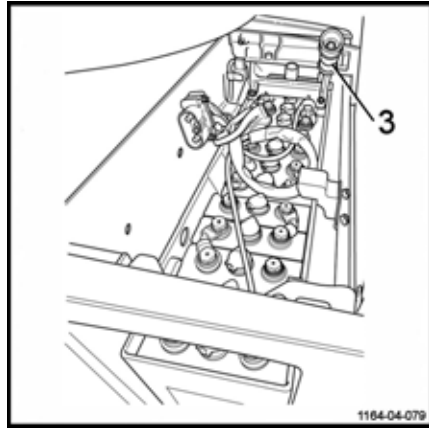

- Pull the battery onto the truck with extraction rollers or the roller frame.
- Replace the battery. Remove the discharged battery and position a charged battery on the roller frame.
- Position the truck with extraction rollers or the roller frame (4) in the upright position next to the battery compartment.

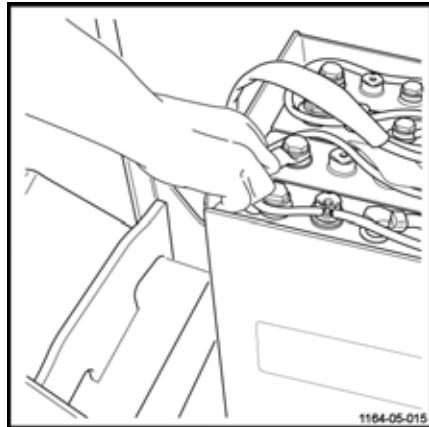

- Carefully push the battery into the compartment. ▷

⚠ DANGER

Risk of trapping fingers

Push the battery from the rear side (A) of the battery. Take care not to trap your fingers by pushing from the top or the side of the battery.

⚠ DANGER

Risk of injury

The battery is correctly positioned but is not yet locked.

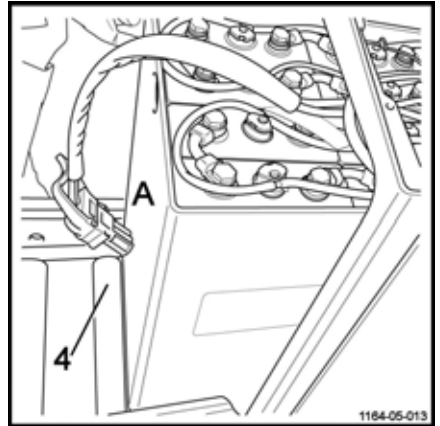

- Push it down to the end of the compartment. ▷

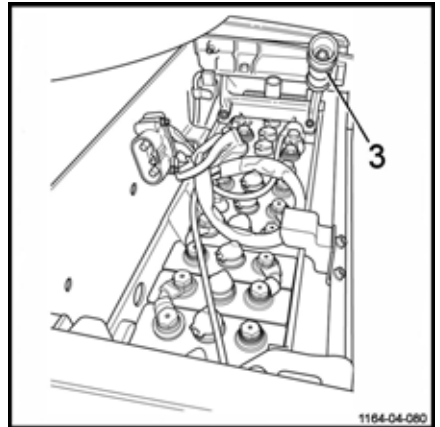

Handling the battery

- Lower and lock the handle (2) of the locking bar (3) in the direction indicated by the arrow. The locking bar must be horizontal and must be right up against the stop (5).

⚠ CAUTION

Risk of locking the battery incorrectly

The locking bar should not in any circumstances be positioned under or on top of the stop. It must be positioned against the stop.

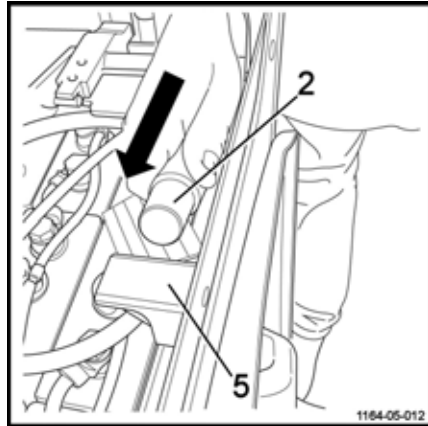

- Reconnect the battery connector.
- Refit the battery hood.
- Return the truck to service.

⚠ WARNING

Risk of injury

Before restarting the truck, ensure that the battery is correctly installed. Check that the battery is locked and that the battery hood is closed.

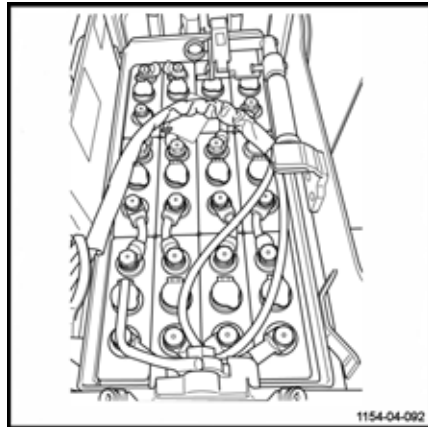

Handling the truck in an emergency

Emergency lowering of the mast



The emergency control (1) allows the mast to be lowered manually in the event of a problem.

This operation is to be performed as follows:

- Open the technical compartment door.
- Loosen the screw (1) using an 8 mm open-ended spanner.

DANGER

Danger of death!

Do not walk underneath raised loads!

Check that no one is in the danger area before manually lowering the mast.

When the forks are fully lowered:

- Loosen the screw (1) using an 8 mm open-ended spanner.
- Close the technical compartment door.

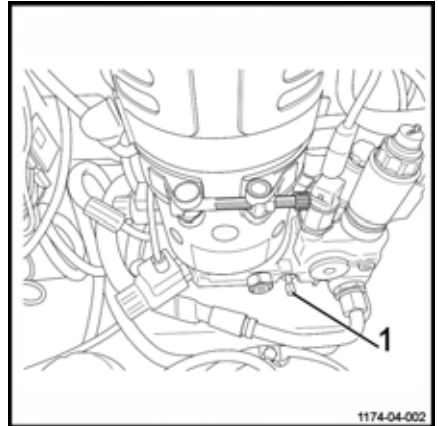

1174-04-002

Handling the truck in an emergency

Truck towing procedure

It is not possible to tow the truck with no electrical function. The electromagnetic brake remains in the closed position.

Truck towing is authorised with a rigid connection (tow bar) if the truck to be towed can no longer be braked. Check that the towing vehicle is sufficiently powerful to pull and brake the truck being towed.

Moving with no battery



NOTE

In the event of an electrical fault or no battery, it is possible to unlock the brake manually.

⚠ CAUTION

This procedure must be carried out by authorised personnel.

- Unload the fork arms, then disconnect the battery. ▷
- Remove the engine cover.
- Two M5 X 35 screws (1) are required.
- Screw the screws (1) to the brake (2) in the holes (3). The brake is then unlocked.

⚠ CAUTION

The truck must only be towed at low speeds.

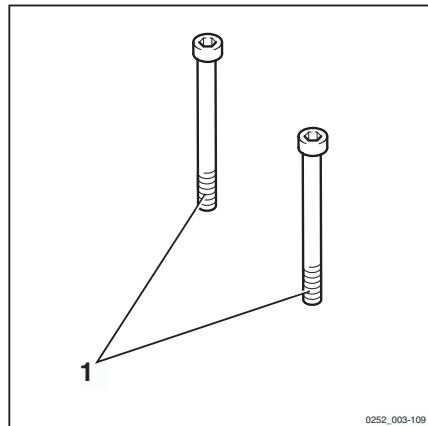

Handling the truck in an emergency

- After towing, chock the truck to prevent it from moving.
- To re-establish brake operation, unscrew and remove the two screws (1).
- Refit the covers.

⚠ WARNING

It is essential that the covers are correctly refitted before the machine is used.

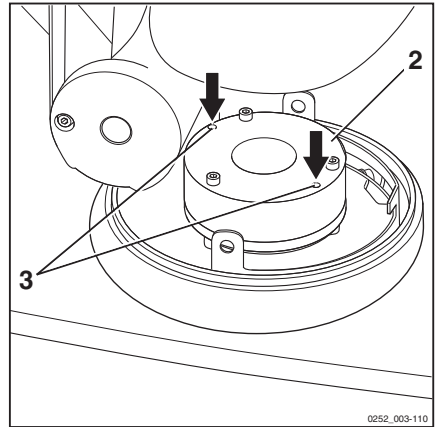

Handling the truck in specific situations

Handling the truck in specific situations

Slinging the truck



⚠ DANGER

Danger of truck falling

Only use slings and a hoist of sufficient quality. Check the weight of the machine (including battery) in order to choose a suitable device. Refer to the technical features.

Observe the following instructions:

- Shut off the truck and disconnect the battery connector.
- Remove any items that could fall.
- Protect all parts that come into contact with the lifting device.
- Attach the lifting device to the sling ring (1).



NOTE

Do not sling the truck by the control module or the steering wheel.

- Carefully lift the truck.

⚠ DANGER

Risk of falling

Make sure no one is under or near the truck when slinging the truck.

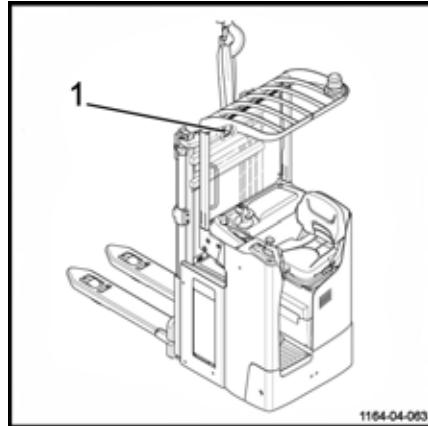

Lifting the truck

⚠ DANGER

Danger of swinging

Truck lifting must be performed carefully.

For some work, it is necessary to lift the truck.

- Lift the load arms.
- Switch off the ignition and disconnect the battery connector.
- Use a jack with adequate lifting capacity.

Front section of the truck:

- Place a jack under the chassis (1).

For work on the lifting device:

- Position the jack under the battery frame (2).

Maintenance of the load wheels:

- Place the jack under the forks in the indicated locations (3).

As a safety precaution, always insert a wooden chock.

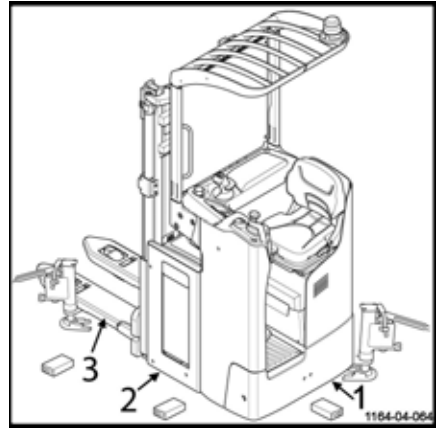

⚠ WARNING

Risk of truck falling

Immobilise and chock the truck after lifting it.

Transporting the truck

⚠ CAUTION

Always switch off the ignition and disconnect the battery.

Never tie down or sling the truck by the control unit or other points not designed for this.

⚠ CAUTION

Risk of damage to the truck.

Use a hoist and woven **NON METALLIC** slings with an adequate lifting capacity. Refer to the load weight shown on the truck's capacity plate.

The lifting operations must be performed by qualified personnel.

Trucks are generally transported by road or by rail.

Handling the truck in specific situations

The truck must be suitably protected from the effects of the weather during transport and storage.

To load or unload the truck, use an inclined plane or a mobile ramp.

If the truck is out of service or if the battery has been removed, sling the truck. See **Chapter 4 Slinging the truck**.

Transporting the truck in the lift

The truck must only be taken in lifts with an adequate loading capacity that are designed for this purpose, and for which authorisation has been received from the operator. Inside the lift, the truck must be immobilised so that no part is in contact with the wall of the lift cage.

Driving on loading bridges

Before crossing a loading bridge, the operator must make sure it is properly attached and secured and its load capacity is sufficient. Cross the loading bridge slowly and carefully. The driver must be sure that the vehicle to be entered is secured sufficiently against movement

DANGER

Danger of death.

Do not stand within the hoist's operating radius or below the lifted truck.

A minimum safety distance of 100 mm from the walls of the lift must always be observed.

Anyone transported with the truck must only enter the lift after the truck has been correctly immobilised and they must exit the lift first.

and that it can support the load of the forklift truck.

The lorry driver and lift truck operator must coordinate the departure time of the lorry.

5

Maintenance

General maintenance information

General maintenance information

General

The following instructions contain all the information required for maintenance of your truck. Carry out the various maintenance work in compliance with the maintenance plan. This will ensure that your truck is reliable and in good working order and that the warranty remains valid.

Maintenance plan

One of the display functions indicates the truck's hours of use. Refer to it and consult the truck's maintenance plan.

The maintenance plan is followed by advice to facilitate work.

Maintenance intervals must be reduced if the truck is used under harsh conditions (extreme heat or cold, large quantities of dust).

Grade and quantity of lubricants and other consumables

Only lubricants and other consumables specified in these operating instructions are authorised for use in maintenance work.

Lubricants and other consumables required for truck maintenance are listed in the maintenance specifications table.

Never mix different grades of grease or oil. If it is absolutely necessary to change brands, make sure to flush thoroughly beforehand.

Before changing any filters or working on the hydraulic system, thoroughly clean the surface and the areas around the part.

All containers used to pour oil must be clean.



Servicing and maintenance personnel training and qualification

Truck maintenance must only be carried out by qualified and authorised personnel.

The annual inspection for prevention of accidents at work must be carried out by a person qualified to do so. The person carrying out this inspection must provide their expertise and opinion without being influenced by economic factors or company internal issues. Safety is the only critical deciding factor.

The person responsible for carrying out the inspection must have sufficient knowledge and experience to be able to assess the condition of the truck and the efficiency of the protective installations in accordance with the technical regulations and principles established for checking industrial trucks.

Battery maintenance staff

Batteries must only be recharged, maintained and changed by specially trained personnel. Personnel must follow the manufacturer's instructions of the battery, the battery charger and the truck.

It is essential to follow the battery maintenance instructions and the battery charger operating instructions.

Maintenance operations that do not require special training

Simple maintenance operations such as checking the hydraulic fluid level or checking the battery electrolyte level can be carried out by persons with no special training.

A specific qualification is not necessary.

Refer to the maintenance section of this manual for further information.

Ordering spare parts and consumables

Spare parts are provided by our spare parts service department. You will find the information required to place an order in the spare parts and fitting catalogue.

Only use spare parts recommended by the manufacturer.

Unauthorised spare parts may increase the risk of accidents due to faults relating to quality or incorrect choices. Anyone who uses non-compliant spare parts must assume full responsibility in the event of an accident.

Safety guidelines for maintenance

Safety guidelines for maintenance

Servicing and maintenance measures

To avoid accidents during servicing and maintenance operations, take all necessary safety measures. For example:

- Ensure that there is no risk of the truck moving or starting up unexpectedly. For this reason, remove the battery connector.

Working on the electrical equipment

Operations on the truck's electrical system must only be carried out when there is no voltage supply.

Operating checks, testing and adjustment work on parts supplied with voltage must only be carried out by personnel:

- who have received detailed instructions
- who have been authorised to perform this work
- who have taken the necessary precautionary measures.

Rings, metal bracelets etc., must be removed before carrying out any operations on electric components.

Remove the electric equipment (which comprises electric components such as the traction controller) before carrying out any welding operations. This precaution prevents this electric equipment from being damaged.

Operations on the electric system require the consent of the manufacturer.

Safety devices

After any repair or maintenance work, it is necessary:

- to refit all safety devices
- to check these for correct operation.

Technical data for inspection and maintenance

Assembly	Consumables/lubricants	Capacities/adjustment values
Hydraulic system	Hydraulic oil	Minimum oil volume: 7.7 litres Maximum oil volume: 8.3 litres
Transmission gear	Transmission gear oil	0.98 l
Traction motor (3 kW)	1F1 fuse	Power: 300 A, quantity: 1
Steering unit ES30–24 (0.185 kW S1)	3F1 fuse	Power: 40 A, quantity: 1
Pump motor (3.2 kW)	1F1 fuse	Power: 300 A, quantity: 1
Control fuse	1F3 fuse	Control: 7.5 A, quantity: 1
Control fuse	1F4 fuse	Control: 5 A, quantity: 1
Battery	Distilled water	As required
Joints	Lithium soap grease	As required

Recommended lubricants

Recommended lubricants

CAUTION

Damage to equipment if non-recommended lubricants are used.

Only use recommended lubricants. Only the lubricants listed below are approved by the manufacturer. Do not mix lubricants. If in doubt, please contact the After-Sales Service Centre.

Hydraulic oil

Recommended oil for standard use:

ISO-L-HM 46 as per ISO 6743-4 or ISO VG46-HLP as per DIN 51524-2

Recommended oil for heavy-duty use:

ISO-L-HM 68 as per ISO 6743-4 or ISO VG68-HLP as per DIN 51524-2

Recommended oil for the cold store version:

ISO-L-HM 32 as per ISO 6743-4 or ISO VG32-HLP as per DIN 51524-2

Transmission oil

Recommended oil:

SAE 85W 90 API GL4

Aerosol can for chains

Standard chain spray

Grease for pinion gear and steering ring

CAUTION

Follow the maintenance and safety guidelines.

Multi-purpose grease

Lithium soap grease with EP agents and MoS 2 **KPF 2N - 20** complying with the standard DIN 51825.



ENVIRONMENT NOTE

Used oil must be stored safely until it is disposed of in accordance with environmental regulations. No one should have access to the used oil. Do not dispose of used oil in drains or allow it to penetrate soil.

Accessing the technical compartment

In order to perform maintenance on various truck components, it is necessary to access the technical compartment.

- Immobilise the truck
- Lower the forks
- Switch off the truck (key or electronic key)
- Press the emergency off switch
- Disconnect the battery connector
- Move the seat all the way forwards
- Remove the mounting screw (1) at the bottom of the door

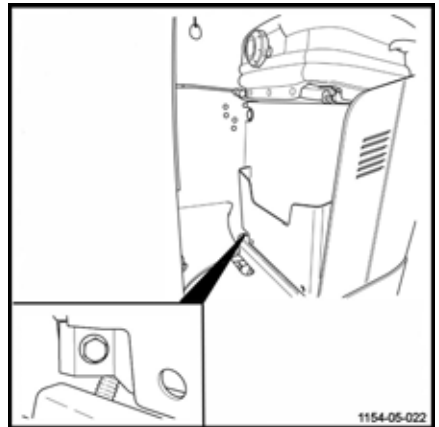

Accessing the technical compartment

- Open the technical compartment door (2) ▷

You must close the technical compartment after the operation is finished.

- Close the door (2)

⚠ CAUTION

Risk of trapping fingers.

Take care not to trap your fingers between the door and the chassis.

Be careful not to trap your fingers in the external hinges (3).

- Refit the mounting screw
- Reconnect the battery connector
- Return the truck to service

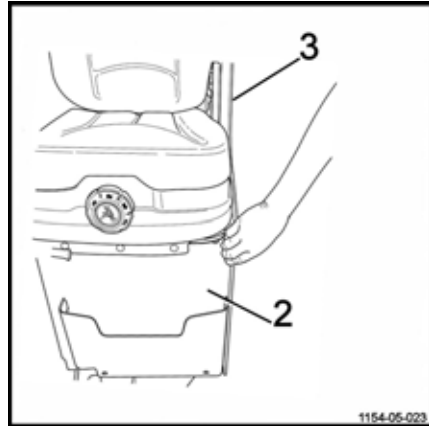

1000-hour maintenance plan

Depending on the application, environmental conditions and driving style, the following procedures should be carried out every 1000, 2000, 3000, 4000, 6000, 7000, 8000 and 9000 hours
Preparation
Clean the truck
Check the error codes using the diagnostic tool
Chassis and equipment
Check the condition of the forks
Check the electromagnetic brake and ensure that it is working correctly
Check and lubricate the hinges
Check the pump motor brushes for wear
Ensure that the floor adjusts and locks correctly
Ensure that the seat adjusts and locks correctly
Check the transmission gear for noise and leaks
Lubricate the gears
Wheels
Check the condition and tightness of the wheels
Check the stabilisers
Electrical equipment
Clean the electric steering system and lifting motors
Check the condition of the cables and the battery sockets and ensure that they are positioned correctly
Check the electrical insulation between the chassis and the electric components
Check the electrical insulation between the chassis and the electronic components
Check the fuses
Check the battery acid level and the electrolyte level
Hydraulics
Check the hydraulic oil level
Check the condition of the pipe lines
Load lift system
Check the condition and the length of the mast chain
Lubricate the forks and the mast guide rollers
Check the condition and mounting of the guard grille
Check the pin clearance

5000-hour maintenance plan

5000-hour maintenance plan

Depending on the application, environmental conditions and driving style, the following procedures should be carried out every 5000 and 10,000 hours
Information
Carry out all 1000-hour maintenance work
Hydraulics
Drain the hydraulic oil

10,000-hour service plan

Depending on the application, environmental conditions and driving style, the following procedures should be carried out every 10,000 hours
Information
Carry out all 1000-hour maintenance work
Carry out all 5000-hour maintenance work
Motor
Drain the transmission gear oil

Chassis, bodywork and fittings

Cleaning the truck

Cleaning instructions

- Park the truck.
- Press the emergency off switch.

⚠ CAUTION

Electrical hazards

The battery must always be disconnected during cleaning procedures.

Washing the outside of the truck

⚠ WARNING

Risk of damage to the truck

- Do not use flammable liquids to clean the truck.
 - The safety rules set out above must be followed to prevent spark formation. They could lead to a short circuit.
 - All components that are sensitive to moisture (particularly electric components) must be protected when the truck is cleaned.
 - Follow the manufacturer's instructions when using the cleaning product.
-
- Clean the truck with a non-flammable cleaning product mixed with water, a sponge and cloths.
 - Specifically clean the oil filler holes and surrounding area as well as the lubricating nipples (before lubrication).

i NOTE

A frequently cleaned truck must be lubricated more regularly.

Cleaning the electrical installations

⚠ WARNING

Electrical hazards

Do not expose electrical equipment (especially motors) to direct jets.

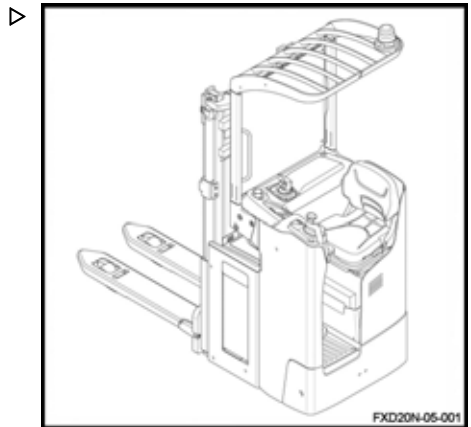

Chassis, bodywork and fittings



NOTE

- *Only use dry cleaning products*
- *Do not remove the cowlings*
- Clean the electrical installations with a non-metal brush and dry with lightly compressed air.

After washing

- Carefully dry the truck (e.g. with compressed air).

WARNING

Use of compressed air

It is advisable to wear protection goggles and a mask.

- Restart the truck in accordance with the instructions.



NOTE

If, despite taking precautions, traces of moisture remain in the motor, dry it using compressed air. After having eliminated any traces of moisture, the truck may be reactivated. Do not do so before then to prevent any corrosion.

General information on battery maintenance

DANGER

Risk of injury

Before carrying out any operations on the electric installation, turn the truck power supply off. Disconnect the battery connector.

Precautions to be taken during battery maintenance

The plugs on the battery cells must always be dry and clean.

Neutralise any spilt battery acid immediately.

The battery terminals and lugs must be clean, lightly covered with grease for terminals and securely tightened.

Charging the battery

During the charging process, the surface of the battery cells must be clear to ensure sufficient ventilation.

Do not place metal objects on the battery.

The battery cover must remain open during charging. See the chapter entitled **Battery charging using an external charger**.

Battery type

Lead or gel batteries are used. It is advisable to choose a compatible charger.

Before charging, ensure that the charger is suitable for the type of battery.

CAUTION

Gel batteries are subject to specific charging, maintenance and treatment instructions. A non-compatible charger may result in a battery failure.

Observe the manufacturer's recommendations.



NOTE

- *The discharge indicators used to check the battery must also be suitable for the type of battery*
- *Contact the relevant After-Sales Service Centre*

Charging the battery

- Park the truck in an area without condensation or pollution and with sufficient ventilation.
- Stop the truck.
- Press the emergency off switch.
- Open the battery hood.
- Follow the instructions.

CAUTION

Do not expose the charger to water, rain, oils, grease or any similar substances.

The charger becomes hot during the operation.

CAUTION

Risk of injury

Do not obstruct the ventilation. Allow the charger to cool down for 10 minutes after charging is complete before touching it. Do not use the charger out of the truck.

Chassis, bodywork and fittings

Checking the condition of the forks ▷

- Check that the forks (1) show no signs of deformation, splits, heavy wear or cracks.

⚠ CAUTION

Truck damage

If the carriage is damaged, have it changed by the After-Sales Service Centre.

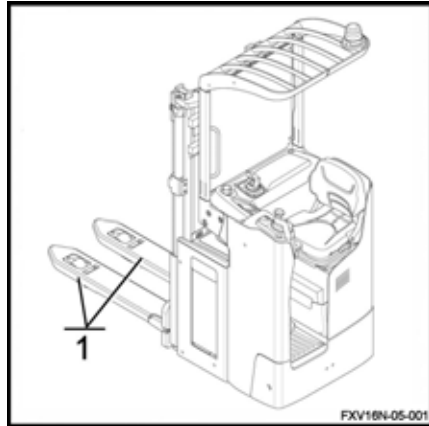

Steering and wheels

Checking the condition of the wheels

- Raise the truck until the wheels are off the ground.
- Check that the wheels rotate freely and remove any objects that may prevent them from turning or may obstruct them.

⚠ CAUTION

Risk of damaging the wheels

In order to avoid any risk of damaging the bearings and tyres of the wheels, it is essential to remove any wires or plastic strips that may wind around the wheel hubs and bearings.

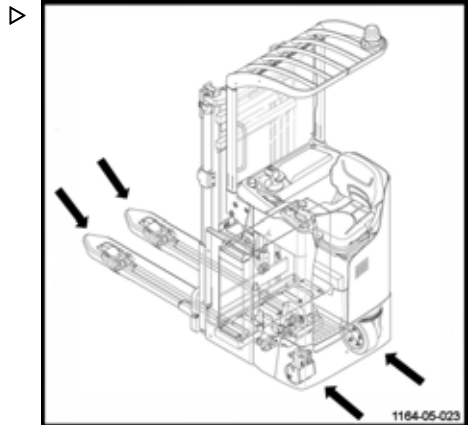

Electrical equipment

Electrical equipment

Cleaning and blowing out the electrical components ▷**⚠ CAUTION**

Electrical hazards

Always disconnect the battery connector before working on an electrical component.

- Press in the emergency off switch.
- Disconnect the battery connector.
- Open the technical compartment hood.
- Blow the electrical components with compressed air.

⚠ WARNING

Use of compressed air

It is advisable to wear protection goggles and a mask.

- Check the condition of the cable harness connector pins.

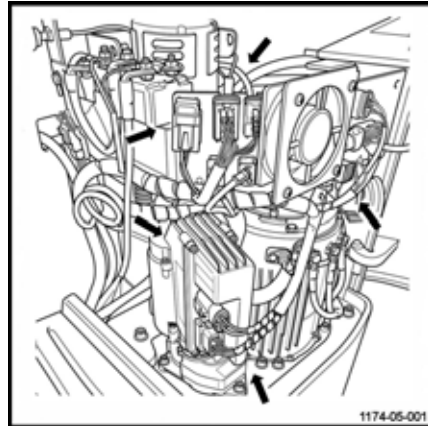
Checking the battery acid level and electrolyte density ▷**NOTE**

Remove the battery from its compartment to check the water level.



⚠ WARNING

The electrolyte (diluted sulphuric acid) is poisonous and corrosive.

- Always wear suitable protective equipment (industrial protection goggles, safety gloves) when working on a battery.
 - Never wear a watch or jewellery when handling battery acid.
 - Do not allow any acid to get onto the clothing or skin or into the eyes. If this does happen, rinse immediately with plenty of clean water.
 - Immediately rinse away any spilled battery acid with plenty of water.
 - In case of injury, seek medical advice immediately.
 - Always follow the safety information provided by the battery manufacturer.
 - Comply with the regulations in force.
-
- Check the battery acid level and electrolyte density according to the battery manufacturer's recommendations.
 - The cell covers of the battery must be kept dry and clean.
 - Any spillage of battery acid must be neutralised immediately.

**ENVIRONMENT NOTE**

Dispose of any used battery acid in accordance with the regulations.

Electrical equipment

Checking the condition of cables, terminals and the battery connector

- Check that the cable insulation is undamaged
- Check that there are no signs of heat build-up in the connections
- Check that the "+" and "-" output terminals are not sulphated (presence of white salt)
- Check the condition of the battery connector contacts and the presence of the keying pin

⚠ CAUTION

Risk of damaging the equipment.

The points mentioned above can cause serious incidents. In the event of an incident, contact our After-Sales Service Centre as quickly as possible.

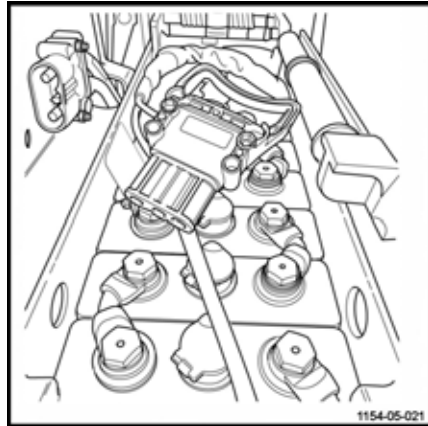

Hydraulic systems

Checking the hydraulic system for leaks

- Switch off the truck and disconnect the battery connector
- Move the seat all the way forwards
- Open the technical compartment door
- Inspect the hydraulic system: pipes, hoses and connections between the pump unit and the cylinders
- Check the cylinders for leaks
- Check that the hoses are attached correctly and show no signs of friction wear
- Check the external pipes and hoses on the technical compartment
- Close the technical compartment door
- Return the truck to service

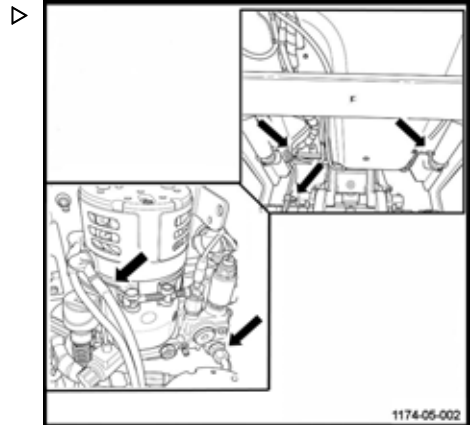

⚠ CAUTION

Risk of damaging the truck

In the event of leakage, please contact the After-Sales Service Centre.

Checking the hydraulic oil level

To check the hydraulic oil level, proceed as follows:

- Immobilise the truck
- Lower the forks
- Switch off the ignition and remove the key
- Press in the emergency off switch
- Disconnect the battery connector
- Move the seat all the way forwards

Hydraulic systems

- Open the technical compartment door ▷

To ensure proper usage of the truck functions, the oil level must be between the minimum (3) and maximum (2) marks on the tank.

- Remove the plug (1). If necessary, top up via the opening
- Refit the plug (1) afterwards

⚠ CAUTION

Risk of damage to hydraulic components

Only use hydraulic oil that complies with the manufacturer's specifications (see table of recommended lubricants).

- Close the technical compartment door
- Reconnect the battery connector
- Return the truck to service

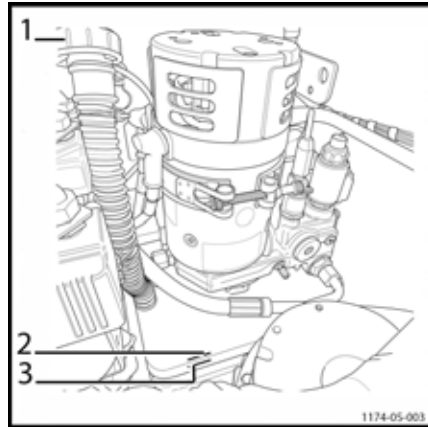

Lift mast

Cleaning and lubricating the chains

NOTE

If the lifting chain is too dirty, clean it.

- Place a recipient underneath the lifting chain.
- Clean using a paraffin-based product (petroleum, fuel oil etc.). Observe the manufacturer's safety guidelines.
- If using a steam jet, do not use additives.
- Immediately dry the chain and its joints with compressed air. Move the chain frequently during this operation.
- Lubricate the chain immediately using a special aerosol chain lubricant.

CAUTION

Risk of the equipment becoming worn or damaged.

Chains are safety components. Use of cold cleaning agents, chemical products, acid or chlorinated products could destroy the chains.

Adjusting the length of the mast chains

NOTE

Depending on the use of the truck, the chains are liable to stretch and as a result they have to be adjusted regularly.

NOTE

Use of high pressure liquid cleaning devices is not advisable.

DANGER

Danger of death and/or risk of serious damage to equipment

On trucks fitted with macrolon mast protection, clean the translucent screen thoroughly after lubrication operations.

Lift mast

- Fully lower the mast.
- Undo the locknut (2)
- Place the chains under slight tension by tightening the nut (1).
- Retighten the locknut (2).

⚠ CAUTION

Risk of the equipment becoming worn or damaged.

After this adjustment, check that the fork carriage does not reach the mechanical stop at the top of the mast during the maximum lift. If this is the case, slacken or replace the chains. We recommend that this operation be carried out by our After-Sales Service Centre.

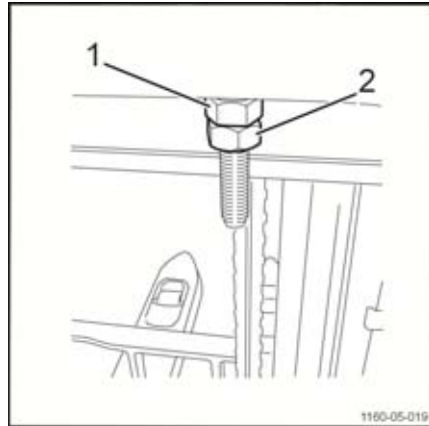

Checking the protective screen

It is important to check the condition of the mast protective screens and to check that the mountings are tightened.

- Check that the protective screen (1) is correctly attached and in good condition (undamaged).
- Replace the protective screen if it is damaged.
- Adhere to the number of mountings defined by the manufacturer.

⚠ WARNING

Risk of serious injury and/or serious damage to equipment

Never touch moving parts and assemblies without first having lowered the equipment to the ground and disconnected the battery.

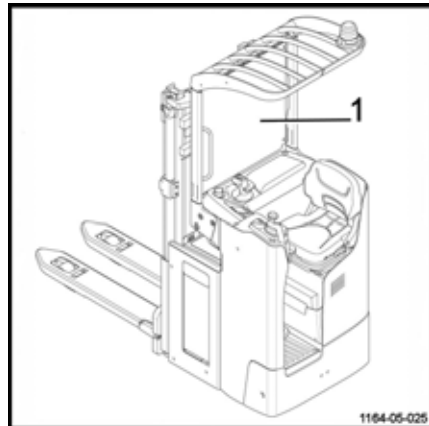

⚠ DANGER**Poor visibility**

The screen must be installed and correctly attached.

Do not attach anything to the screen that could affect the visibility of the forks.

When cleaning the fork carriage side, only clean the screen when the fork carriage is in the lowered position.

Storage and decommissioning

Storage and decommissioning

Storage of truck

Precautions should be taken if the truck must not be used for a reasonably long period. The operations depend on the length of time it is unused.

Long-term truck storage

The following work must be carried out on the truck to prevent corrosion if it needs to be stored for a long period of time. If the truck is to be stored for more than two months, it must be positioned in a clean and dry area. The area must be well-ventilated with no risk of freezing.

The following operations must be performed:

- Clean the truck thoroughly.
- Check the hydraulic oil level and refill if necessary.
- Lower the forks onto a suitable support (e.g. a pallet) until the chains are slack.
- Coat any unpainted metal parts with a thin layer of oil or grease.
- Grease all hinges and joints.
- Check battery condition and electrolyte density. Maintain the battery in accordance with the manufacturer's requirements. (Follow the instructions).
- Spray contacts with an aerosol product designed for contacts.
- Raise and chock the truck: the wheels must not touch the ground in order to prevent irreversible deformation of the tyres.
- Cover the truck with a cotton cover to protect it from dust.

⚠ CAUTION

We recommend that you do not use a plastic sheet as this encourages condensation to form.

Consult the service department for further measures to take if the truck must be stored for a longer period of time.

Recommissioning after storage

If the truck has been stored for more than six months, it must be checked carefully before being recommissioned. This check is similar to the workplace accident prevention inspection. It is therefore necessary to check all points and systems that are important for truck safety.

Carry out the following operations:

- Clean the truck thoroughly.
- Grease all hinges and joints.
- Check the condition and density of electrolyte, and, if necessary, recharge the battery.
- Check that there are no traces of condensation water in the hydraulic oil. Drain if necessary.
- Carry out the same maintenance work as for the first time it was commissioned.
- Commission the truck.
- In particular, check the following during start-up:
 - traction, control and steering.
 - brakes (service brake and parking brake).
 - lifting device.

Permanent Putting Out of Commission (Destruction)

When scrapping the truck, it is necessary to:

- Remove the various parts of the truck (covers, battery, chains, motors etc.)
- Sort out the components depending on their type: pipes, rubber components, lubricants, aluminium, iron etc.
- Before scrapping the truck, notify the competent authorities of your country in writing.
- After receiving the authorisation from the competent authorities, remove any components according to national standards.



NOTE

The client is solely responsible for any irregularities he has committed during or after the scrapping of the truck's components and the removal of components.

Storage and decommissioning

6

Technical specifications

FXV 14N / 16N datasheet

FXV 14N / 16N datasheet

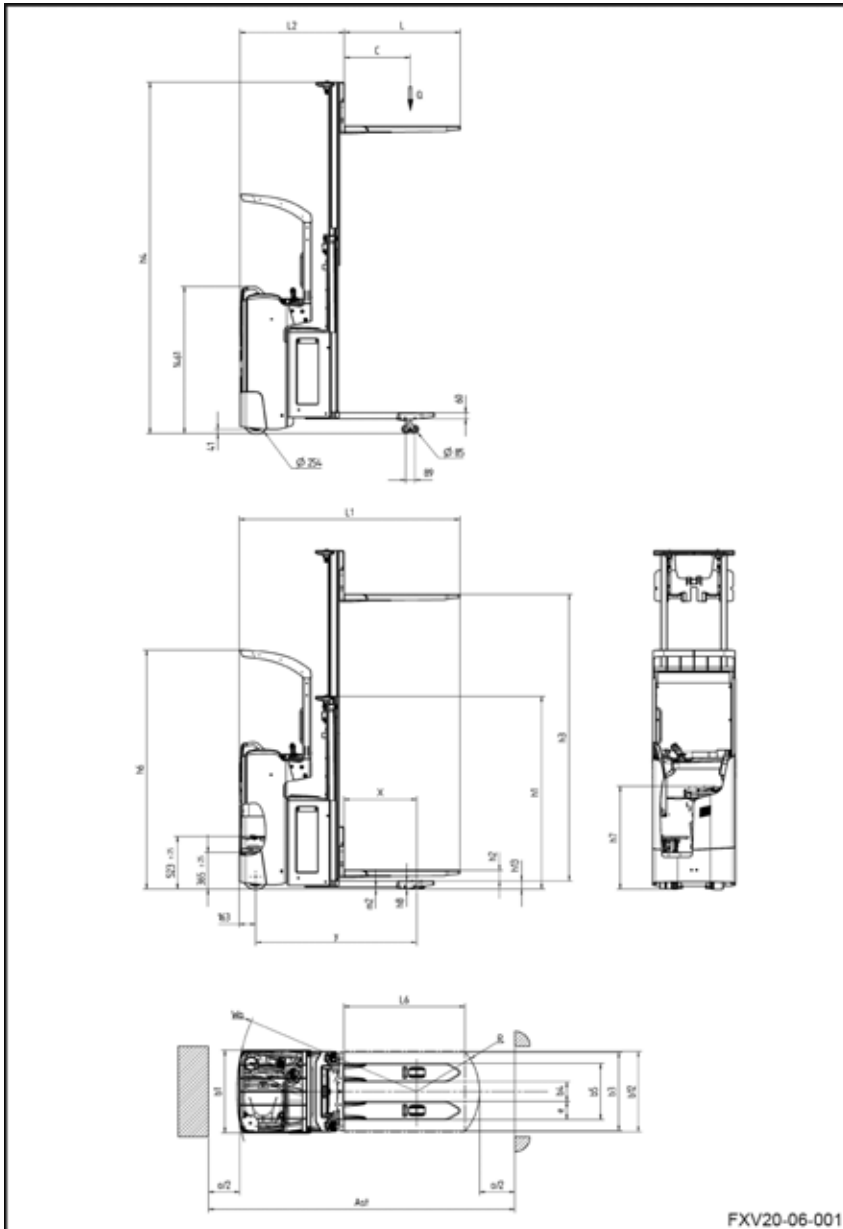

DESCRIPTION			FXV 14N / FXV 16N	FXV 14Ni / FXV 16Ni
1.1	Manufacturer		STILL	
1.2	Model type		FXV 14N / FXV 16N	FXV 14Ni / FXV 16Ni
1.3	Method of propulsion: battery, diesel, petrol, LPG, mains power		Battery	Battery
1.4	Driving: manual, pedestrian, standing, seated, order picking		Seated	Seated
1.5	Main lift nominal capacity only: LP/LI; LI only	Q (kg)	1400/1600	1400 (2000)/1600 (2000)
1.6	Centre of gravity	C (mm)	600	600
1.8	Distance from load wheel axle to load mating face (± 5 mm)	X	724	724
1.9	Wheelbase (± 5 mm)	Y	1597	1597

WEIGHT			FXV 14N / FXV 16N	FXV 14Ni / FXV 16Ni
2.1	Kerb weight with battery ($\pm 10\%$)	kg	1580 ⁽²⁾	1499 ⁽²⁾
2.2	Load per laden axle, drive side/load side ($\pm 10\%$)	kg	1271/1909 ⁽¹⁾	1179/1920 ⁽¹⁾
2.3	Load per unladen axle, drive side/load side ($\pm 10\%$)	kg	1050/530 ⁽¹⁾	971/528 ⁽¹⁾

WHEELS			FXV 14N / FXV 16N	FXV 14Ni / FXV 16Ni
3.1	Tyre: polyurethane, rubber, drive side/load side		P+P/P	P+P/P
3.2	Drive wheel dimensions (width at the ground)	\emptyset x L (mm)	$\emptyset 254$ x L102	$\emptyset 254$ x L102
3.3	Wheel dimensions, load side	\emptyset x L (mm)	$\emptyset 85$ x L85 (bogies: $\emptyset 85$ x L60)	$\emptyset 85$ x L85 (bogies: $\emptyset 85$ x L60)
3.4	Additional wheels (dimensions)	\emptyset x L (mm)	2 x $\emptyset 140$ x L50	2 x $\emptyset 140$ x L50
3.5	Number of wheels at drive side/load side (X = drive wheel)		1X + 1/2 (1X + 1/4)	1X + 1/2 (1X + 1/4)
3.6	Drive side track width (± 5 mm)	mm	541	541
3.7	Load side track width (± 5 mm)	mm	380	380

DIMENSIONS			FXV 14N / FXV 16N	FXV 14Ni / FXV 16Ni
4.2	Lowered mast height (± 5 mm)	h1 (mm)	1915	1915
4.3	Free lift (± 5 mm)	h2 (mm)	150	150
4.4	Lift (± 5 mm)	h3 (mm)	2844	2844

FXV 14N / 16N datasheet

4.5	Extended mast height	h4 (mm)	3364 ⁽⁴⁾	3364 ⁽⁴⁾
4.6	Initial lift	h5 (mm)	/	125
4.7	Overhead guard height (cab)	h6 (mm)	2378	2378
4.8	Seat height relative to the SIP/height of support (± 5 mm)	h7 (mm)	1024	1024
4.1 0	Load arm/ground height	h8 (mm)	80	80
4.1 5	Height at the ends of the fork and on load mating face (± 5 mm)	h13 (mm)	86	86
4.1 9	Total length (0/+5 mm)	l1 (mm)	2187	2187
4.2 0	Length to front of forks (± 5 mm)	l2 (mm)	1037	1037
4.2 1	Total width (± 5 mm)	b1 (mm)	820	820
4.2 2	Fork dimensions	s/e/l (mm)	71/180/1150	71/180/1150
4.2 3	Load arm dimensions	b3 (mm)	75/150/1115	75/150/1115
4.2 4	Fork carriage width	b4 (mm)	780	780
4.2 5	Outside fork spread, minimum/maximum (± 5 mm)	b5 (mm)	560	560
4.2 6	Inside load arm spread	b4 (mm)	255	255
4.3 2	Ground clearance at the centre of the wheelbase (± 2 mm)	m2 (mm)	30	20
4.3 3	Dimension of the b12 x L6 load	mm	800 x 1200	800 x 1200
4.3 4	Aisle width with predetermined load	Ast (mm)	2606 ⁽³⁾	2606 ⁽³⁾
4.3 5	Turning radius (minimum) (± 20 mm), Initial lift raised/lowered	Wa (mm)	1783	1783

PERFORMANCE DATA			FXV 14N / FXV 16N	FXV 14Ni / FXV 16Ni
5.1	Travel speed when laden/unladen ($\pm 5\%$)	km/h	10/10	10/10
5.2	Initial lift speed when laden/unladen ($\pm 10\%$)	m/s	0.045/0.088	0.045/0.088
	Main lift speed when laden/unladen ($\pm 10\%$)	m/s	0.144/0.447	0.144/0.447
5.3	Initial lift lowering speed when laden/unladen ($\pm 10\%$)	m/s	0.076/0.072	0.076/0.072

	Main lift lowering speed when laden/unladen ($\pm 10\%$)	m/s	0.343/0.342	0.343/0.342
5.8	Maximum gradient (0 kg, 1200 kg, 2000 kg)	%	20/11/-	20/11/9
5.9	Acceleration time (10 m)	s	6.1/5	6.1/5
5.1 0	Service brake		electromagnetic	electromagnetic

DRIVE SYSTEM			FXV 14N / FXV 16N	FXV 14Ni / FXV 16Ni
6.1	Traction motor, S2, 60 minutes	kW	3.0	3.0
6.2	Lift motor, S3, at 10% utilisation	kW	3.2	3.2
6.3	Battery type in accordance with DIN 43 535		3 PzS SL	3 PzS SL
6.4	Battery voltage and capacity (discharge in 5 hours)	V/Ah	24/375	24/375
			4PzS SL Li-ion 205 Ah: 23/205	
			4PzS SL Li-ion 410 Ah: 23/410	
6.5	Battery weight ($\pm 10\%$)	(kg)	290	290
	Battery weight with tray ($\pm 10\%$)		4PzS SL Li-ion 205 Ah: 312	
	Battery weight with tray ($\pm 10\%$)		4PzS SL Li-ion 410 Ah: 351	
6.6	Energy consumption according to standardised VDI cycle	kWh/1h	1.65	1.65
6.7	Turnover output according to VDI cycle	t/h	64	64
6.8	Energy consumption at turnover output	kWh/1h	2.26	2.26

MISCELLANEOUS			FXV 14N / FXV 16N	FXV 14Ni / FXV 16Ni
8.1	Speed control (AC controller)		LAC	LAC
10. 7	Noise level at operator's ears (± 2.5)	dB (A)	65	65
	Vibrations transmitted to the operator (EN 13059)	m/s ²	0.56	0.56

- 1) Weight according to line 2.1
- 2) With battery line 6.5
- 3) $A_{st} = W_a + R + a$ (pallet stacker)

Safety distance $a = 200$ mm

FXV 14N / 16N mast types

FXV 14N / 16N mast types

Mast type	Standard						
	1844S	2344S	2844S	3244S	3744S	4144S	4644S
h1	1415	1665	1915	2115	2365	2565	2815
h1'	1490	1740	1990	2190	2440	2640	2890
h2	150	150	150	150	150	150	150
h3	1844	2344	2844	3244	3744	4144	4644
h4	2364	2864	3364	3764	4264	4664	5164

Mast type	Duplex				
	1844D	2344D	2844	3244D	3744D
h1	1415	1665	1915	2115	2365
h1'	/	/	/	/	/
h2	895	1145	1395	1595	1845
h3	1844	2344	2844	3244	3744
h4	2364	2864	3364	3764	4264

Mast type	Triplex		
	4266T	4716T	5316T
h1	1915	2065	2265
h1'	/	/	/
h2	1395	1545	1745
h3	4266	4716	5316
h4	4786	5236	5836

A

Accessing the technical compartment. . .	111
Address of manufacturer.	I
Adjusting the floor.	43
Adjusting the length of the mast chains. .	125
Adjusting the seat.	43
Aerosol can for chains.	110

B

Batteries.	32
Battery	
Closing the battery hood.	91
Opening the battery hood.	91
Type.	90
Battery acid.	14
Before leaving the truck.	76
Before picking up a load.	73
Braking.	32, 53
Braking by releasing the drive switch. .	36, 54
Braking by reversing the drive direction.	36, 54

C

CE labelling.	3
Changing the side access battery.	94
Charging the battery.	117
Charging the battery using an external charger.	92
Checking the battery acid level and elec- trolyte density.	120
Checking the brakes.	36
Checking the cables, terminals and the battery connector.	122
Checking the condition of the forks. . . .	118
Checking the emergency off switch.	36
Checking the horn.	37
Checking the protective screen.	126
Checks prior to start-up.	34
Cleaning and lubricating the chains. . . .	125
Cleaning the truck.	115
Climatic conditions.	8
cold store.	87
Cold store usage.	87
Consumables.	13
Battery acid safety instructions.	14
Disposal.	15

Oil Safety Information.	13
Safety information for handling hydraul- ic fluid.	14
Contact details.	I
Copyright and property rights.	3

D

Defining directions.	52
Description of the Dynamic Load Control (DLC).	77
Description of use.	8
Destruction.	129
Display of the drive wheel position.	45
Display operating unit.	27
Display unit	
Activity indicator.	48
Drive program.	48
Error codes menu.	49
Operator presence.	45
Settings.	47
Start-up screen.	50
Temperature.	47
Warnings.	47
Disposing of components and batteries. . .	9
Drive program	
Blue Q mode.	55
Hare mode.	55
Tortoise mode.	55
Driver rights, duties and rules of behaviour.	18
Drivers.	18
Driver's compartment.	24, 32
Drive system.	32
Driving.	52
Driving on loading bridges.	104
Driving safety guidelines.	51
During work.	85

E

EC declaration of conformity.	4
Electrical equipment	
Cleaning and blowing out the compo- nents.	120
Electromagnetic braking.	54
Electronic key (option).	25
Emergency lowering.	99

F	
Features.	32
FleetManager™	
Colour code for the LEDs.	63
Commissioning a truck equipped with a keypad or an electronic key.	62
Commissioning a truck equipped with an RFID reading device.	62
Description.	61
Disconnecting a truck equipped with a keypad or electronic key.	65
Disconnecting a truck equipped with an RFID reading device.	66
Disconnecting the truck.	65
Start-up.	62
FXV 14N / 16N datasheet.	132
FXV 14N / 16N mast types.	136
G	
General.	2, 106
General information on battery maintenance.	117
General view.	22
General view of the technical compartment.	23
Grade and quantity of lubricants and other consumables.	106
Grease for pinion gear and steering ring.	110
H	
Handling a single load.	73
Horn.	54
Hydraulic fluid.	14
Hydraulic oil.	110
Hydraulic system	
Checking the hydraulic oil level.	123
Checking the hydraulic system for leaks.	123
I	
Identification label.	5
In the event of error code L354.	86
J	
Joystick function	
Front of the joystick.	56
Rear of the joystick.	57
L	
Lift control elements.	69
Lifting	
Base lift.	70
Main lift.	69
Lifting the truck.	103
Load handling safety rules.	67
Location of markings.	28
M	
Maintenance plan.	106
1000 hours.	113
5000 hours.	114
Managing battery charging.	47
Managing residual capacity.	81
Mast.	32
Multi-purpose grease.	110
N	
No Dynamic Load Control (DLC).	78
Noise emission values.	16
O	
Oils.	13
Operating company.	18
Operator presence detection.	41
Ordering spare parts and consumables.	107
Order picking.	90
P	
Permanent Putting Out of Commission.	129
Picking up a load at a height.	76
Picking up a load from the ground.	74
Precautions to be taken during battery maintenance.	117
Progressive stopping of the carriage in the lower position.	72
Prohibition of use by unauthorised persons.	19
Proper usage.	8
R	
Reading the capacity plate.	71
Recommended lubricants.	110
Residual dangers, residual risks.	17
Restarting work.	89
Rules for using the Dynamic Load Control.	84

S

Safety devices. 108

Safety Inspection. 20

Seat heater
 Optional. 44

Selection buttons. 45

Serial number. 29

Service plan
 10,000 hours. 114

Servicing and maintenance measures. 108

Setting a load down on the ground. 74

Settings menu. 49

Slinging the truck. 102

Spare parts list. 7

Specialist. 18

Stability. 17

Stacking a load. 75

Starting on a slope. 60

Starting the truck. 85

Starting up. 35

Steering. 32

Steering knob option. 57

Stepping on/off the truck. 40

Stopping the truck. 89

Symbols used. 9

T

Technical data for inspection and maintenance. 109

Technical description. 32

Transmission oil. 110

Transporting a load. 74

Transporting the truck. 103

Transporting the truck in the lift. 104

Travelling down slopes. 60

Travelling up slopes. 59

Truck operating instructions. 38

U

Unauthorised use. 9

Using Dynamic Load Control (DLC) version 1. 79

Using Dynamic Load Control (DLC) version 3. 81

Using the truck on a slope. 59

V

Vibrations
 Vibration characteristics for vibrations to which the body is exposed. 16

W

Wheels
 Checking the condition of the wheels. 119

Working on the electrical equipment. 108

STILL GmbH

11748011551 EN - 02/2021 - 09