

Original instructions

STILL
ELECTRONIC
DOCUMENTATION
SYSTEM

LTX10, LTX20, LTX-T04

Tractor

LTX-



first in intralogistics

Address of manufacturer and contact details ▷

STILL GmbH
Berzeliusstraße 10
22113 Hamburg, Germany
Tel. +49 (0) 40 7339-0
Fax: +49 (0) 40 7339-1622
Email: info@still.de
Website: <http://www.still.de>

Made in China



Rules for the operating company of industrial trucks

In addition to these operating instructions, a code of practice containing additional information for the operating companies of industrial trucks is also available.

This guide provides information for handling industrial trucks:

- Information on how to select suitable industrial trucks for a particular area of application
- Prerequisites for the safe operation of industrial trucks
- Information on the use of industrial trucks
- Information on transport, initial commissioning and storage of industrial trucks

Internet address and QR code ▷

The information can be accessed at any time by pasting the address <https://m.still.de/vdma> in a web browser or by scanning the QR code.



1 Foreword

Your industrial truck	2
General	2
Conformity marking	3
Declaration that reflects the content of the declaration of conformity	4
Information about documentation	5
Documentation scope	5
Date of edition and latest update of this manual	6
Copyright and trademark rights	6
Explanation of symbols used	7
Explanation of the cross-references	7
Definition of directions	8
Illustrations	8
Environmental considerations	9
Packaging	9
Disposal of components and batteries	9

2 Introduction

Technical Description	12
Use of the truck	14
Intended use of the trucks	14
Proper usage	14
Unauthorised use	14
Place of use	15
Residual risks	16
Residual dangers, residual risks	16
Stability	16
Special risks associated with using the truck and attachments	17

3 Safety

Definition of terms used for responsible persons	20
Operating company	20
Specialist	20
Drivers	20
Basic principles for safe operation	22
Insurance cover on company premises	22
Warning regarding non-original parts	22

Modifications and refitting	22
Medical equipment	23
Safety tests	24
Regular safety inspection of the truck	24
Electrical insulation test	25
Safety regulations for handling consumables	26
Permissible consumables	26
Oils	26
Battery acid	27
Disposal of consumables	28
Emissions	28
Safety devices	30
Damage, defects and misuse of safety devices	30
Battery connection cables	30
EMC - Electromagnetic Compatibility	31
4 Overviews	
General view	34
Labels	36
Identification plate	37
Operating devices 1193	39
Accessory bar (optional)	40
Display unit	41
Electronic key (option)	44
RF device (optional)	45
5 Use	
Commissioning	48
Before driving	48
Designation	50
Checks before initial use	51
Daily checks before use	52
Checking the working environment	53
Operating instructions	53

Commissioning	54
Emergency stop switch	55
Determining the drive direction	56
Forward/reverse travel	56
Steering unit	57
Stand-on/seated driving operation	57
Driving on a slope	61
Brake, horn and lighting	63
Coupling	64
Coupling the trailer	65
Driving the truck with cargo	68
Transporting the truck	70
Truck storage	71
Measures to be carried out before storing a forklift truck	71
Putting the tow tractor back into service	71
Disposal of old trucks	72
6 Maintenance	
General maintenance information	74
General	74
Staff training and qualifications for maintenance and repairs	74
Battery maintenance personnel	74
Services not requiring special qualifications	75
Ordering spare parts and wear parts	75
Recommended lubricants	76
Technical inspection and maintenance characteristics	77
Safety regulations for maintenance	78
Safety measures for maintenance and repair	78
Work on the electrical equipment	78
Safety devices	78
Settings	78
Daily checks before starting work	79
Checking the travel direction control function	79
Checking the brakes	79
Testing the steering unit	81
Testing safety devices	81

Checking the battery charging status	83
Opening the battery hood	84
Plugging in/unplugging the battery connector	84
Checking the condition of cables, terminals and battery connector	85
Removing/replacing the battery	85
Maintenance plan as required	92
Cleaning	92
Accessing the electrical compartment	92
Checking the auxiliary seat condition	94
Steering tiller:check condition	94
Check fuses	94
Inspection and maintenance overview	96
1000 hour service plan	96
10000 hour service plan	97
Tractor motor	99
Traction motor:Cleaning the motor housing	99
Gearbox	100
Servicing the reducer	100
Steering/braking/wheels	101
Steering/wheels/brakes	101
Checking the brake air gap	104
Battery	105
Checking the on-board charger	105
Battery maintenance	105
Removing/replacing the battery	106
7 Technical data	
Datasheet	114

1

Foreword

Your industrial truck

Your industrial truck

General

The truck described in these operating instructions corresponds to the applicable standards and safety regulations.

If the truck is to be operated on public roads, it must conform to the existing national regulations for the country in which it is being used. The driving permit must be obtained from the appropriate office.

The truck has been fitted with state-of-the-art technology. Following these operating instructions will allow the truck to be handled safely. By complying with the specifications in these operating instructions, the functionality and the approved features of the truck will be retained.

Get to know the technology, understand it and use it safely - these operating instructions provide the necessary information and help to avoid accidents and to keep the truck ready for operation beyond the warranty period.

Therefore:

- Before commissioning the truck, read the operating instructions and follow the instructions.
- Always follow all of the safety information contained in the operating instructions and on the truck.

Conformity marking

The manufacturer uses the conformity marking to document the conformity of the industrial truck with the relevant directives at the time of placing on the market:

- CE: in the European Union (EU)
- UKCA: in the United Kingdom (UK)
- EAC: in the Eurasian Economic Union

The conformity marking is applied to the nameplate. A declaration of conformity is issued for the EU and UK markets.

An unauthorised structural change or addition to the industrial truck can compromise safety, thus invalidating the declaration of conformity.



Declaration that reflects the content of the declaration of conformity

Declaration

STILL GmbH
Berzeliusstraße 10
22113 Hamburg Germany

We declare that the specified machine conforms to the most recent valid version of the directives specified below:

Industrial truck type	corresponding to these operating instructions
Model	corresponding to these operating instructions

- "Machinery Directive 2006/42/EC" ¹⁾
- "Supply of Machinery Safety Regulations 2008, 2008 No. 1597" ²⁾

Personnel authorised to compile the technical documents:

See declaration of conformity

STILL GmbH

¹⁾ For the markets of the European Union, the EU candidate countries, the EFTA States and Switzerland.

²⁾ For the United Kingdom market.

The declaration of conformity document is supplied with the industrial truck. The declaration shown explains the conformity with the provisions of the EC Machinery Directive and the Supply of Machinery Safety Regulation 2008, 2008 No. 1597.

The declaration of conformity must be carefully stored and made available to the responsible authorities if necessary. It must also be handed over to the new owner if the industrial truck is sold on.

An unauthorised structural change or addition to the industrial truck can compromise safety, thus invalidating the declaration of conformity.

Information about documentation

Documentation scope

- Operating instructions
- Operating instructions for attachment parts (special equipment)
- Spare parts list
- VDMA rules for the proper use of industrial trucks (EU countries only)

These operating instructions describe all measures necessary for the safe operation and proper maintenance of the truck in all possible variants at the time of printing. Special designs to meet customer requirements are documented in separate operating instructions. If you have any questions, please contact your service centre.

Enter the production number and the year of production located on the nameplate in the field provided:

Production no.

Year of production

Please quote these numbers for all technical enquiries.

Operating instructions are provided with each truck. These instructions must be stored care-

fully and must be available to the driver and operator at all times.

If the operating instructions are lost, the operator must immediately request a replacement from the manufacturer.

The operating instructions are included in the spare parts list and can be reordered there as a spare part.

Personnel responsible for operating and maintaining the equipment must be familiar with these operating instructions.

The operating company (see ⇒ Chapter "Definition of terms used for responsible persons", Page 20) must ensure that all operators have received, read and understood these instructions.

Thank you for reading and complying with these operating instructions. If you have any questions or suggestions for improvements, or if you have found any faults, please contact your service centre.

Information about documentation

Date of edition and latest update of this manual

The publication date of these operating instructions is printed on the cover sheet.

The manufacturer makes continuous efforts to improve its industrial trucks, and therefore reserves the right to implement changes and to accept no claims concerning the information provided in this manual.

To receive technical assistance, please contact the service centre authorised by your closest manufacturer.

Copyright and trademark rights

These instructions must not be reproduced, translated or made accessible to third parties—including as excerpts—except with the express written approval of the manufacturer.

Explanation of symbols used

DANGER

Compulsory procedure that must be followed to avoid danger to life or physical harm.

WARNING

Compulsory procedure that must followed to avoid injury.

CAUTION

Compulsory procedure that must be followed to avoid material damage and/or destruction.

NOTE

For technical requirements that require special attention.

ENVIRONMENT NOTE

To prevent environmental damage.

Explanation of the cross-references

Cross references are used to direct the reader to the appropriate section or chapter.

Examples:

- Cross reference to a section: ⇒ Chapter "Explanation of the cross-references", Page 7
- Cross reference to a chapter: ⇒ Chapter "Definition of terms used for responsible persons", Page 20

Information about documentation

Definition of directions

The directions front (1), rear (3), right (2) and left (4) are seen from the position of the operator; the load is at the rear.

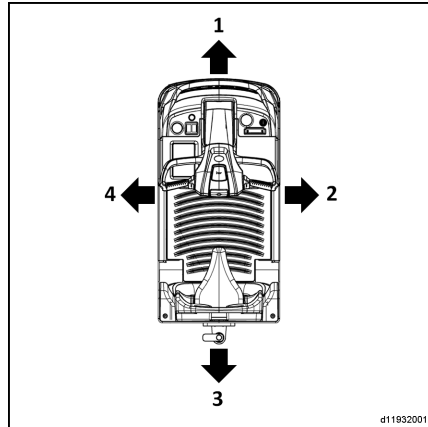

Illustrations

At many points in this documentation the (mostly sequential) operation of certain functions or operating procedures is explained. To illustrate these operations, schematic representations of a truck are used.



NOTE

These schematic representations do not represent the design state of the documented truck. They only serve to illustrate operating procedures.

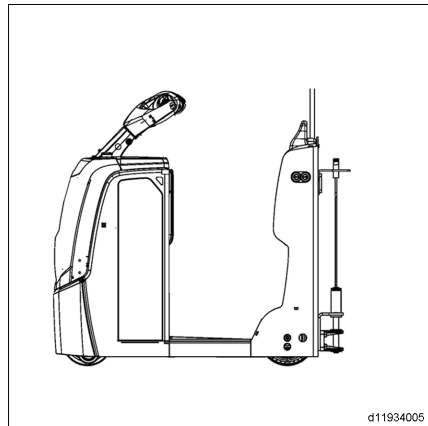

Environmental considerations

Packaging

During delivery of the truck, certain parts are packaged to provide protection during transport. This packaging must be removed completely prior to initial start-up.



ENVIRONMENT NOTE

The packaging material must be disposed of properly after delivery of the truck.

Disposal of components and batteries

The truck is composed of different materials. If components or batteries need to be replaced and disposed of, they must be:

- disposed of,
- treated or
- recycled in accordance with regional and national regulations.



NOTE

The documentation provided by the battery manufacturer must be observed when disposing of batteries.



ENVIRONMENT NOTE

We recommend working with a waste management company for disposal purposes.

Environmental considerations

2

Introduction

Technical Description

Technical Description

Maximum design load capacity of LTX10, LTX20 and LTX-T04 type 1193 tow tractors:

LTX10	1000 kg
LTX20	2000 kg
LTX-T04	400/1000 kg

These tractors are used in seated /standing mode.



NOTE

The platform of LTX-T04 can load 400kg cargo, and at the same time, the truck can tow 1000kg cargo.

The LTX10, LTX20 and LTX-T04 are configured:

- As standard with a 3 point wheel base and 2 castor wheels
- 10 km/h in forward gear, 3 km/h in reverse gear, laden and unladen for the LTX10.
- 8 km/h in forward gear, 3 km/h in reverse gear, laden and unladen for the LTX20.
- 8 km/h in forward gear, 3 km/h in reverse gear, laden and unladen for the LTX-T04.
- Optional forward/reverse coupling approach control for coupling to a trailer.

LTX10, LTX20 travels a distance of 0.3 m each time the button (forward or reverse) is held down.

LTX-T04 travels a distance of 4 m each time the button (forward) is held down.

These tractors offer excellent performance, thanks to their structure that includes:

- a fixed front chassis with the mechanical and electrical units necessary for truck movements
- a battery (technical compartment)
- a driver's compartment
- a driving platform
- a tractor chassis at the rear

Maintenance and programming the truck is facilitated by the on-board Can Bus technology.

Drive

The traction and travel of the tractor are provided by:

- a 1.5 kW traction motor.
- a drive unit placed in the centre of the chassis.
- two stabilisers fixed on the right and the left of the chassis.

Power is supplied by a 24 volt lead-acid battery with a capacity of 200 Ah.

The power supply to the traction motor is controlled by an L.A.C controller which provides perfect control of speed, acceleration and braking.

Braking

The LTX10, LTX20 and LTX-T04 Type 1193 are equipped with two braking systems:

- An electromagnetic safety brake that also serves as a parking brake.

The latter is applied automatically in the following situations:

- the driver leaves the driving platform.
- truck stationary, direction reverser in neutral.
- power off.

The safety brake is applied automatically in the event of a fault in the traction and/or steering control systems.

- A counter-current electrical brake that is applied automatically when the control is released and when the direction of travel is reversed.

Balancing mechanism

The 3-point chassis has 2 height-adjustable fixed castor wheels.

Towing system

Nominal load:

- LTX10:1000 kg
- LTX20:2000 kg
- LTX-T04:400/1000 kg

Coupling options:

single position of LTX10: 276 mm

single position of LTX20: 276 mm

single position of LTX-T04:165 mm

Driver's compartment

The standard equipment in the driver's compartment comprises:

– **A dashboard with:**

- a multifunction display;
- an ignition key or digicode allowing the truck to be used by authorised personnel without an ignition key;
- an emergency stop button;
- a diagnostic connector;
- trays for pens and pencils;
- A suspended platform with operator presence sensor.
- A height-adjustable auxiliary seat, incorporating:
 - height adjustment locking handle

Use of the truck

Use of the truck

Intended use of the trucks

CAUTION

This machine was designed for the transport and storage on racks (pallet stackers only) of loads packed on pallets or in industrial containers designed for this purpose.

The dimensions and capacity of the pallet or container must be adapted to the load being transported and must ensure stability.

The table of characteristics and performance attached to this user manual gives you the information you need to check that the equipment is suitable for the work being carried out.

Any specific usage must be authorised by the site manager; an analysis of the potential risks associated with this usage will enable him to put in place any necessary additional safety measures.

Proper usage

The truck described in these operating instructions is suitable for transporting loads.

The truck may only be used for its proper purpose as set out and described in these operating instructions.

If the truck is to be used for purposes other than those specified in the operating instructions, the approval of the manufacturer and, if applicable, the relevant regulatory authorities must be obtained beforehand to prevent hazards.

The maximum load is specified on the capacity rating plate (load diagram) and must not be exceeded; see also the chapter entitled "Before picking up a load".

Unauthorised use

Any danger caused as a result of unauthorised use becomes the responsibility of the operator or driver and not that of the manufacturer.

Use for purposes other than those described in these operating instructions is prohibited.

Transporting people is prohibited.

The tow tractor must not be used in areas where there is a risk of fire, explosion or corrosion, or in areas that are particularly dusty.

Place of use

The truck can be used outdoors and in buildings. The truck must not be used outside in bad weather! Operation on public roads is permitted only if the special equipment specified in the Road Traffic Licensing Regulations is installed.

The various regulations applicable in different countries for driving the truck on public roads must be observed.

The sites on which the truck is used must comply with the current regulations (condition of the ground, lighting etc.).

The ground must have sufficient load capacity (concrete, asphalt). The driveways, work areas and working widths must correspond with the specifications in the operating manual (see⇒ Chapter "Before driving", Page 48).

The truck can be operated on a slope in compliance with the data and specifications indicated (see ⇒ Chapter "Before driving", Page 48).

If your truck is to be used in a refrigerated storage area, it must be configured accordingly and, if necessary, approved for that environment (see ⇒ Chapter "Designation", Page 50).

The operator (see ⇒ Chapter "Definition of terms used for responsible persons", Page 20) must ensure adequate fire protection in the vicinity of the truck for its use. Depending on the use, additional fire protection must be provided on the truck. In doubt, contact the relevant authorities.

Residual risks

Residual risks

Residual dangers, residual risks

Despite all operational precautions and compliance with standards and rules, the possibility of additional risks when using the tow tractor cannot be entirely excluded.

The tow tractor and all its components comply with the regulations relating to current applicable safety rules.

Persons in the vicinity of the tow tractor must be particularly cautious and react immediately in the event of any malfunction, incident, breakdown etc.

WARNING

Personnel in contact with the tow tractor must be informed of the risks related to using the tow tractor.

These operating instructions draw your attention to the safety rules.

The risks are:

- Escape of consumables due to leaks, ruptured lines and tanks etc.
- Risk of accident when driving over difficult ground such as slopes, soft or irregular surfaces or in poor visibility etc.

Stability

The stability of the truck has been tested to the latest technological standards and is guaranteed if the truck is used properly and according to its intended purpose. These standards only take into account the static and dynamic tipping forces that can arise during specified use in accordance with the operating rules and intended purpose. The risk of exceeding the moment of tilt that arises from improper use or incorrect operation cannot be excluded in extreme cases, and will impact stability.

The risks can include:

- loss of stability due to unstable or sliding loads etc.
- cornering at excessive speeds.

- Falling, tripping etc. when moving on the tow truck, especially in the wet, with leaking consumables or on icy surfaces
- Loss of stability due to the load being unstable or the load slipping etc.
- Risk of fire and explosion due to batteries and electrical voltages
- Human error — disregarding safety regulations

It is important to adjust the speed of the tow tractor depending on the load and ground conditions.

The stability of the tow tractor has been tested to the latest standards. These standards only take account of the static and dynamic tilting forces that can arise during operation that complies with the specifications and operating rules. Risks caused by misuse or incorrect operation that jeopardise the stability cannot be ruled out in extreme situations.

- moving with a load that is protruding to the side.
- turning and driving diagonally across slopes.
- driving on slopes with the load on the downhill side.
- loads that are too wide.
- swinging loads.
- ramp edges or steps.

Special risks associated with using the truck and attachments

Approval from the manufacturer and attachment manufacturer must be obtained each time the truck is used in a manner that falls outside the scope of normal use, and in cases where the driver is not certain that he can use the truck correctly and without the risk of accidents.

3

Safety

Definition of terms used for responsible persons

Definition of terms used for responsible persons

Operating company

The operating company is the natural or legal person or group who operates the truck or on whose authority the truck is used.

The operating company must ensure that the truck is only used for its intended purpose and in compliance with the safety guidelines set out in these operating instructions.

The operating company must ensure that all users read and understand the safety information in these instructions.

The operating company is responsible for the scheduling and correct performance of regular safety checks.

It is recommended that these checks comply with national performance specifications.

Specialist

A specialist is deemed to be:

- A person whose experience and technical training has allowed him to develop relevant knowledge of industrial trucks
- A person who is also familiar with national health and safety regulations and generally recognised technical directives and conven-

tions (standards, VDE regulations, technical regulations of other European Union member states or countries that are signatories to the treaty that established the European Economic Area). This expertise allows him to assess the condition of industrial trucks in terms of health and safety

Drivers

This truck may only be driven by suitable persons who are at least 18 years of age, have been trained in driving, have demonstrated their skills in driving and handling loads, and have been specifically designated to drive the truck. Specific knowledge of the truck is also necessary.

wear to be able to drive and brake in complete safety.

The driver must be familiar with the operating instructions and have access to them at all times.

Driver rights, duties and rules of behaviour

The driver must be duly informed of his rights and duties.

The driver must:

- Have read and understood the operating instructions
- Have familiarised himself with safe operation of the truck
- Be physically and mentally able to drive the truck safely

The driver must be granted the required rights.

The driver must wear protective equipment (protection suit, safety helmet, industrial goggles and protective gloves) that is appropriate for the conditions, the task and the load to be lifted. The driver must also wear safety foot-

DANGER

The use of drugs, alcohol or medications that affect reactions impair the ability to drive the truck.

Individuals under the influence of the above-mentioned substances are not permitted to perform work of any kind on or with the truck.

Definition of terms used for responsible persons

Prohibition of use by unauthorised persons

The driver is responsible for the truck during working hours. He must not allow unauthorised persons to operate the truck.

When leaving the truck, the driver must secure it against unauthorised use.

Basic principles for safe operation

Basic principles for safe operation

Insurance cover on company premises

In many cases, company premises are restricted public traffic areas.



NOTE

The business liability insurance should be reviewed to ensure that, in the event of any damage caused in restricted public traffic areas, there is insurance cover for the truck in respect of third parties.

Warning regarding non-original parts

Original parts, attachments and accessories are specially designed for this truck. We specifically draw your attention to the fact that parts, attachments and accessories supplied by other companies have not been tested and approved by STILL.

CAUTION

Installation and/or use of such products may therefore have a negative impact on the design features of the truck and thus impair active and/or passive driving safety.

We recommend that you obtain approval from the manufacturer and, if necessary, from the relevant regulatory authorities before installing such parts. The manufacturer accepts no liability for any damage caused by the use of non-original parts and accessories without approval.

Modifications and refitting

If your truck is to be used in specific conditions (refrigerated warehouse or flameproof protection), it must be specially equipped and approved for this purpose, if applicable.

If your truck is used for work that is not specified in the guidelines or in this manual and it must be modified or refitted for this purpose,

please remember that any structural modification may affect truck handling while driving and its stability, and may lead to accidents. You should therefore contact the manufacturer before carrying out any modification. No modification that may affect stability is permitted without the manufacturer's authorisation.

Any constructional modification or transformation of your truck is forbidden without prior written permission from the manufacturer. Authorisation from the relevant authority may also be required.

You may only make a modification or alteration to your truck, **if the manufacturer is no longer in business and is unlikely to be taken over by another company**, and only on condition that:

- the modification or alteration is designed, tested and implemented by one or more engineers who are experts in the field of industrial trucks and their safety
- records are kept of the design, test(s) and implementation of the modification or alteration
- appropriate changes are approved and made to the capacity plate(s), decals, labels and operating instructions
- a permanent and clearly visible label is attached to the truck indicating the nature of the modification or alteration as well as the date of the modification or alteration, and the name and address of the company that carried out the work.

Medical equipment

When a driver is wearing medical equipment, e.g. heart pacemaker or hearing aids, the operation of this equipment may be affected. A doctor or the manufacturer of the medical equipment should be asked whether the equipment is sufficiently protected against electromagnetic interference.

Safety tests

Safety tests

Regular safety inspection of the truck ▷

Safety inspection based on time and extraordinary incidents

The operating company must ensure that the truck is checked by a specialist at least once a year or after particular incidents.

As part of this inspection, a complete check of the technical condition of the truck must be performed with regard to accident safety. In addition, the truck must be thoroughly checked for damage that could potentially have been caused by improper use. A test log must be created. The results from the inspection must be retained until a further two inspections have been carried out.

The inspection date is indicated by an adhesive label on the truck.

- Arrange for the service centre to perform periodic safety inspections on the truck.
- Observe guidelines for checks carried out on the truck in accordance with FEM 4.004.

The operator is responsible for ensuring any defects are remedied without delay.

- Contact your service centre.

**NOTE**

Observe the national regulations for your country!

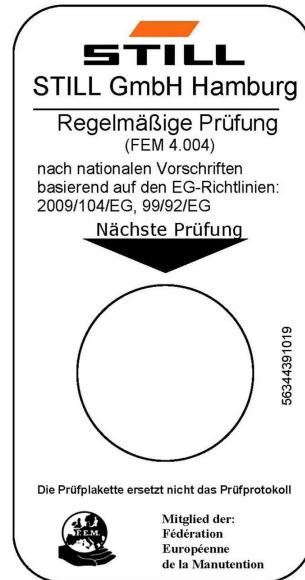

Electrical insulation test

The truck insulation must have sufficient resistance, which must be evaluated according to DIN 57117 and DIN 43539, VDE 0117 and VDE 0510 at least once a year.

NOTE

The truck's electrical system and the battery must be tested separately.

Measuring battery insulation resistance

NOTE

Nominal battery voltage < test voltage < 500 [V].

- Measure the insulation resistance using a suitable instrument.

The insulation resistance is sufficient when it has a nominal value of at least **1000 [Ω/V]** against the chassis.

Please contact the service department.

Measuring the insulation resistance of the electrical system

NOTE

Nominal battery voltage < test voltage < 500 [V].

- Make sure that there is no voltage in the truck's electrical system.
- Measure the insulation resistance using a suitable instrument.

The insulation resistance is sufficient when it has a nominal value of at least **1000 [Ω/V]** against the chassis.

Please contact the service department.

Safety regulations for handling consumables

Safety regulations for handling consumables

Permissible consumables

DANGER

Failure to observe the safety regulations relating to consumables may result in a risk of injury, death or damage to the environment.

- Observe the safety regulations when handling such materials.

Refer to the maintenance data table for the permissible substances that are necessary for operation.

Oils



DANGER

Oils are flammable!

- Follow the statutory regulations.
- No smoking, fires or naked flames!



DANGER

Oils are toxic!

- Avoid contact and consumption.
- If vapour or fumes are inhaled, move to fresh air immediately.
- In the event of contact with the eyes, rinse thoroughly (for at least 10 minutes) with water and then consult an eye specialist.
- If swallowed, do not induce vomiting. Seek immediate medical attention.



WARNING

Prolonged intensive contact with the skin can result in dryness and irritate the skin!

- Avoid contact and consumption.
- Wear protective gloves.
- After any contact, wash the skin with soap and water, and then apply a skin care product.
- Immediately change soaked clothing and shoes.

⚠ WARNING

There is a risk of slipping on spilled oil, particularly when combined with water!

- Spilt oil should be removed immediately with oil-binding agents and disposed of according to the regulations.

**ENVIRONMENT NOTE**

Oil is a water-polluting substance!

- *Always store oil in containers that comply with the applicable regulations.*
- *Avoid spilling oils.*
- *Spilt oil should be removed immediately with oil-binding agents and disposed of according to the regulations.*
- *Dispose of old oils according to the regulations.*

Battery acid**⚠ WARNING**

Battery acid contains dissolved sulphuric acid. This is toxic.

- Avoid touching or swallowing the battery acid at all costs.
- In case of injury, seek medical advice immediately.

**⚠ WARNING**

Battery acid contains dissolved sulphuric acid. This is corrosive.

- When working with battery acid, use appropriate PSA (rubber gloves, apron, protection goggles).
- When working with battery acid, never wear a watch or jewellery.
- Do not allow any acid to get onto clothing or skin or into the eyes. If this does happen, rinse immediately with plenty of clean water.
- In case of injury, seek medical advice immediately.
- Immediately rinse away spilt battery acid with plenty of water.
- Follow the statutory regulations.

Emissions



ENVIRONMENT NOTE

- Dispose of used battery acid in line with the applicable regulations.

Disposal of consumables



ENVIRONMENT NOTE

Materials that accumulate during repair, maintenance and cleaning must be collected properly and disposed of in accordance with the national regulations for the country in which the truck is being used. Work must only be carried out in areas designated for the purpose. Care must be taken to minimise any environmental pollution.

- Soak up any spilt fluids such as brake fluid or gearbox oil using an oil-binding agent.
- Neutralise any spilt battery acid immediately.
- Always observe national regulations concerning the disposal of used oil.

Emissions

Noise emissions

The values are determined using the methods set out in the European Standard EN12053 (measuring noise emissions from industrial trucks, based on Standards ISO 11201 and EN ISO 3744 and in compliance with standard EN ISO 4871). According to these methods, the truck generates the following sound pressure levels : Permanent sound pressure level in the driver's compartment:

LpAz	75 dB (A)
------	-----------

However, the specified noise levels in the truck cannot be used to determine the noise emissions occurring in workplaces in accordance with the most recent version of Directive 2003/10/EC (daily personal noise pollution). If necessary, these values must be determined directly at the workplace in the actual

conditions present there (additional noise sources, special application conditions, sound reflections).

Vibrations

Machine vibrations were measured using an identical machine, in accordance with Standard CEN EN 13059 "Test methods for measuring vibration by industrial trucks".

Trials have shown that the amount of hand-arm vibration when using the steering wheel and controls is less than 2.5 m/s^2 for industrial trucks. For this reason there is no statutory limit for this type of measurement.

The vibration to the operator:

- For LTX10, LTX20, 1.30 / 1.46 (Stand / Seat)
- For LTX - T04, 1.09 / 1.11 (Stand / Seat)

The personal stress on the operator caused by vibrations during a day's work must be noted if necessary at the actual work place so as to be able to consider all the other factors such as the state of the track, the intensity of use, etc.

Traction battery emissions

Battery charging releases an explosive oxygen/hydrogen gas mixture (oxyhydrogen). This gas mixture is highly explosive and must not be ignited. Risk of explosion may be reduced in a well-ventilated area, away from all sources of open flames or sparks. Obey the safety regulations when handling batteries.

Safety devices

Safety devices

Damage, defects and misuse of safety devices

The driver must report any damage or other defects to the truck or attachment immediately to the supervisory personnel.

Trucks and attachments that are not functional or safe may not be used until they have been properly repaired.

Do not remove or deactivate safety devices and switches.

Fixed set values may only be changed with the approval of the manufacturer.

Work on the electrical system (e.g. connecting a radio, additional headlights etc.) is only permitted with the manufacturer's written approval. All electrical system interventions must be documented.

Battery connection cables

CAUTION

Using sockets with NON-ORIGINAL battery connection cables can be dangerous (see purchase references in the parts catalogue)

EMC - Electromagnetic Compatibility

Electromagnetic Compatibility (EMC) is a key quality feature of the truck.

EMC means

- Limiting electromagnetic interference emissions to a certain level, so as to ensure the trouble-free operation of other equipment in the environment.
- Ensuring adequate immunity to electromagnetic interference, so as to ensure normal operation in the intended position of use under expected electromagnetic interference conditions.

Therefore, EMC testing first measures the electromagnetic interference emitted by the

truck, then checks whether there is sufficient resistance to electromagnetic interference in the intended position of use. A number of measures have been taken to ensure the electromagnetic compatibility of the truck.

CAUTION

The truck must comply with EMC regulations.

When replacing the truck components, EMC protection components must be reinstalled and connected.

4

Overviews

General view

General view

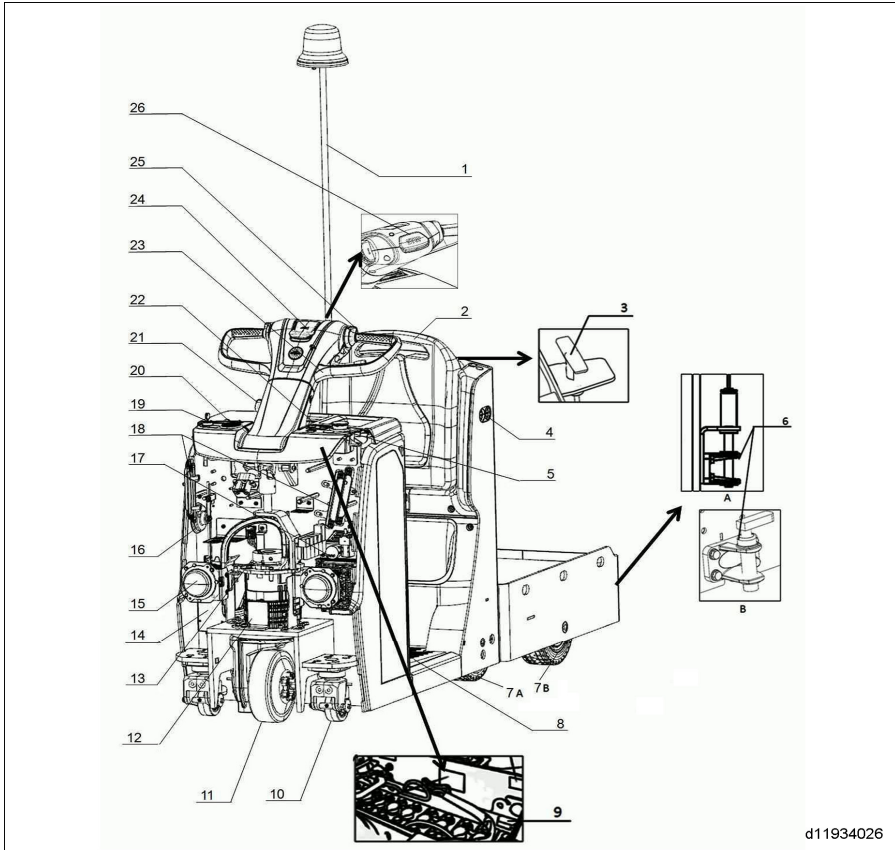

d11934026

- | | | | |
|----|---|----|-----------------------|
| 1 | Flashing beacon | 13 | Electromagnetic brake |
| 2 | Adjustable auxiliary seat | 14 | Charger |
| 3 | Hook cable | 15 | Working lights |
| 4 | Coupling approach buttons | 16 | Horn |
| 5 | Emergency stop button | 17 | Fuse & Relay box |
| 6 | Hook | 18 | Indicator lights |
| 7A | Load wheels (LTX10 / LTX20), mounted on main chassis. | 19 | Key switch |
| 7B | Load wheels (LTX -T04), mounted on tow platform. | 20 | Indicator |
| 8 | Operator platform | 21 | Diagnostic connector |
| 9 | Battery | 22 | Control panel |
| 10 | Stabiliser wheels | 23 | Steering handlebar |
| 11 | Drive wheel | 24 | Horn button |
| 12 | Electrical motor | 25 | Direction switch |
| | | 26 | Stop button |

**NOTE**

The LTX10 / LTX20 tow tractor is equipped with a tow coupling for hitching to a trailer, so there is no tow platform. The LTX -T04 tow tractor has a tow platform and a tow coupling.

Labels

Labels

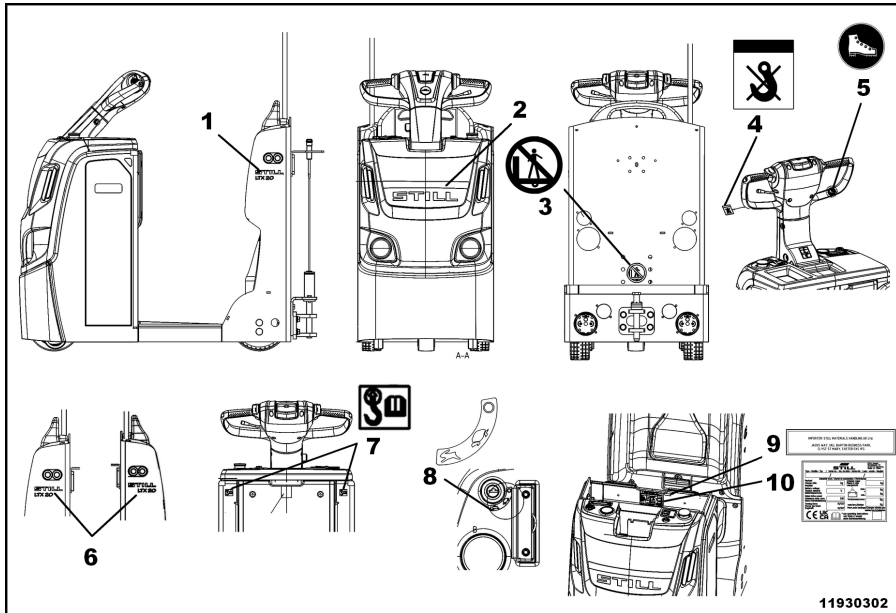

11930302

- | | | | |
|---|--------------------------------|----|--------------------------------|
| 1 | STILL Logo & truck model label | 6 | STILL Logo & truck model label |
| 2 | STILL Logo | 7 | sling sticker |
| 3 | forbid transport person label | 8 | key label |
| 4 | forbid hook label | 9 | Importer label (for UK) |
| 5 | working shoes label | 10 | nameplate |

Identification plate

Nameplate, variant 1

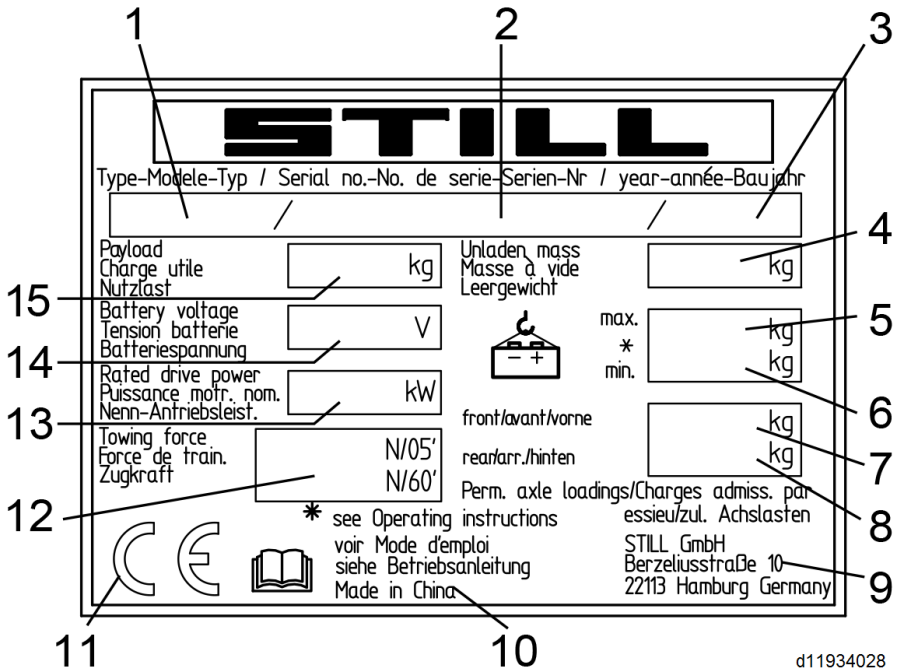

- | | | | |
|---|--|----|---|
| 1 | Type | 8 | Rear axle loading in kg |
| 2 | Serial number | 9 | Manufacturer |
| 3 | Year of manufacture | 10 | Refer to technical data listed in this operating instructions for more detailed information |
| 4 | Unladen mass in kg | 11 | CE label |
| 5 | Max. permissible battery weight in kg (for electric trucks only) | 12 | Towing force |
| 6 | Min. permissible battery weight in kg (for electric trucks only) | 13 | Rated drive power in kW |
| 7 | Front axle loading in kg | 14 | Battery voltage in V |
| | | 15 | Payload in KG |

Identification plate

Nameplate, variant 2

1
STILL GmbH
Berzellusstr. 10
D-22113 Hamburg
Made in China

Type - Modèle - Typ / Serial no. - No. de série - Serien-Nr. / year - année - Baujahr

Industrial truck / Chariot de manutention / Flurförderzeug

14
13
12
11
10
9

2
3
4
5
6
7

Payload / Charge utile / Nutzlast [] kg

Battery voltage / Tension batterie / Batteriespannung [] V

Rated drive power / Puissance motr. nom. / Nenn-Antriebsleistung [] kW

Towing force / Force de train / Zugkraft [] N/05*
[] N/60*

Unladen mass / Masse à vide / Leergewicht [] kg

max. / * / min. [] kg

front/avant/vorne [] kg

rear/arr./hinten [] kg

Perm.axle loadings/Charges admiss.par
essieu/zul.Achslasten []

CE UK CA * see operating instructions / voir Mode d'emploi / siehe Betriebsanleitung

8
11930301

- | | | |
|---|---|---|
| 1 | Manufacturer | the EFTA States and Switzerland UKCA |
| 2 | Serial number | mark for the United Kingdom market EAC |
| 3 | Year of manufacture | mark for the Eurasian Economic Union market |
| 4 | Unladen mass in kg | |
| 5 | Max. / Min. permissible battery weight in kg (for electric trucks only) | 10 |
| 6 | Front / Rear axle loading in kg | 11 |
| 7 | Data matrix code | 12 |
| 8 | Refer to technical data listed in this operating instructions for more detailed information | 13 |
| 9 | Conformity marking: CE mark for the markets of the EU, the EU candidate countries, | 14 |
| | | Type |



NOTE

- It is possible for there to be multiple conformity markings on the nameplate.
- The EAC mark may also be located in the immediate vicinity of the nameplate.



NOTE

Nameplate provided according to collocation requirements.

Operating devices 1193

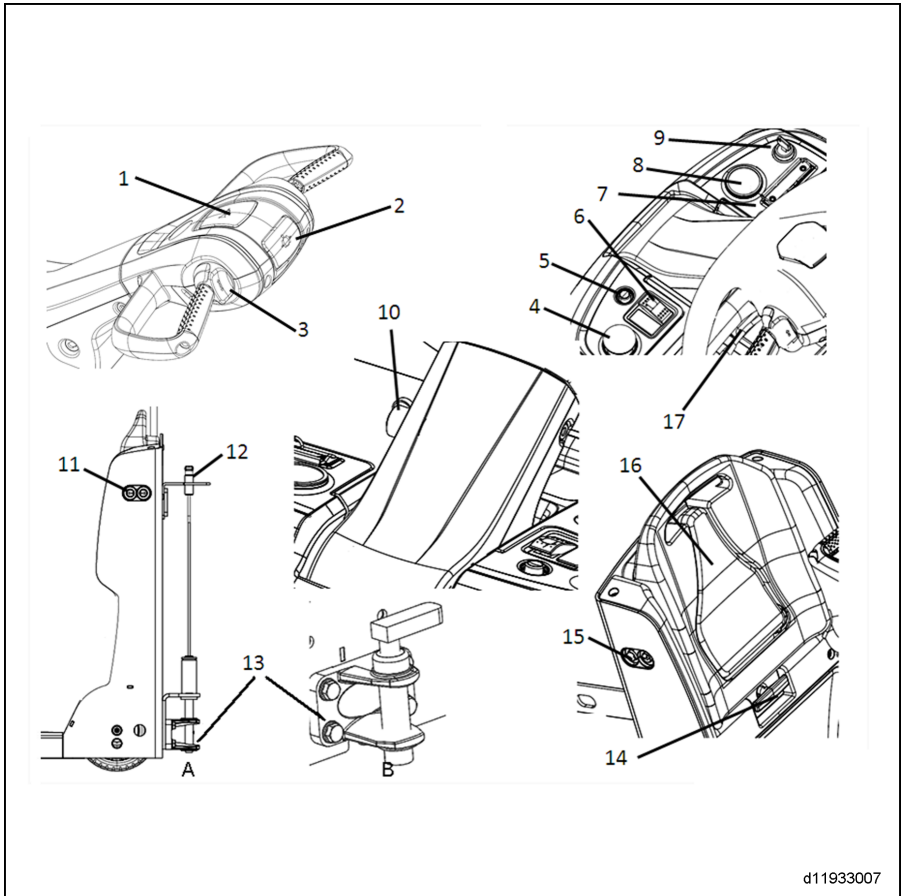

d11933007

- | | | | |
|---|--|----|--|
| 1 | Horn button | 10 | Diagnostic interface |
| 2 | STOP button | 11 | Forward/reverse inching switch |
| 3 | Forward/reverse drive direction switch | 12 | Steel cable |
| 4 | Emergency stop switch | 13 | Tow coupling |
| 5 | Tiller adjustment button | 14 | Auxiliary seat, backrest height adjustment cable |
| 6 | Lighting control switch | 15 | Forward/reverse inching switch |
| 7 | Ticket clip | 16 | Fold-down auxiliary seat |
| 8 | Display unit | 17 | Turn indicator light switch |
| 9 | Power switch | | |

Accessory bar (optional)

Accessory bar (optional)

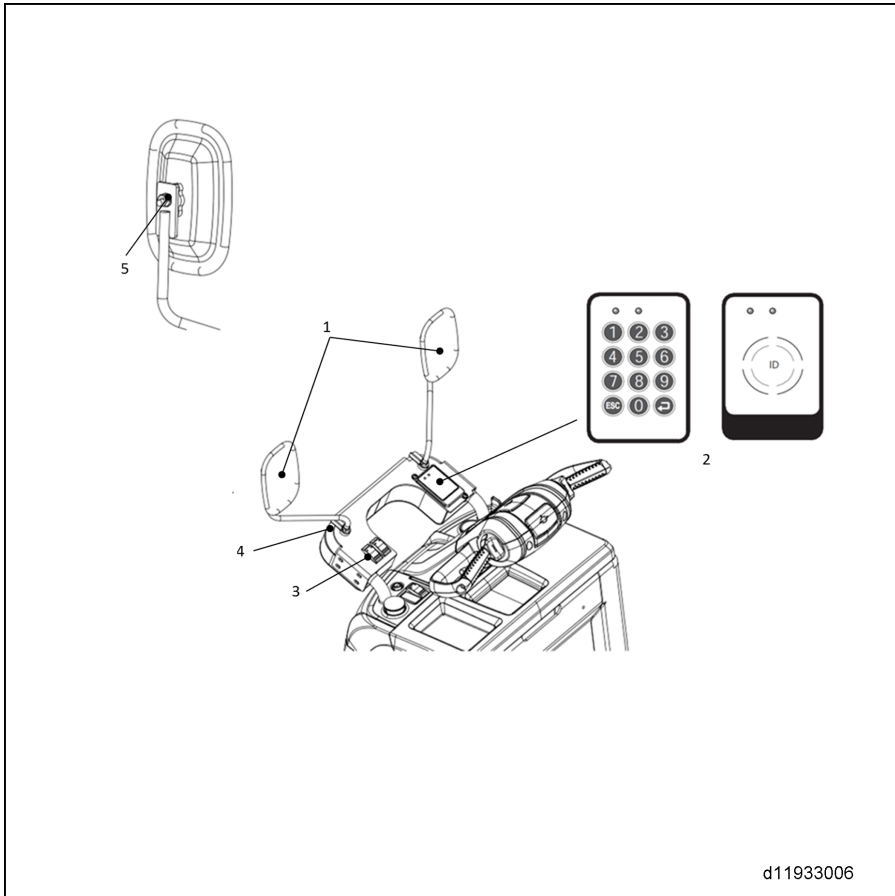

- | | | | |
|---|-------------------------------------|---|-----------------|
| 1 | Rear-view mirror | 4 | Mirror adjuster |
| 2 | RF device option or Digicode option | 5 | Mirror adjuster |
| 3 | Additional switch option | | |

**NOTE**

For more information, please check the optional booklet. The part No. of the booklet is 50988011937.

⚠ CAUTION

Beware of pinching fingers when adjusting the tiller.

Keep your fingers away from moving parts as shown at the arrow to avoid any risk of injury.

⚠ WARNING

Risk of serious injury and/or serious damage to the equipment.

Don't operate the manipulation components which are equipped on the accessory bar during travelling.

⚠ CAUTION

Risk of damage to the equipment.

Pay attention to the dimension of the truck which is equipped with the rear mirror. Maximum width of the truck could be 856 mm.

Display unit

Overview

The main functions of the display unit include:

- displays battery level
- displays maintenance service hours
- displays fault codes
- indicates fault messages by means of flashing indicator light or symbols
- displays battery charge status
- equipped with backlight

The controller transmits battery power, hours, fault codes and other information to the display unit over the CAN-BUS network.

Display unit

Display unit

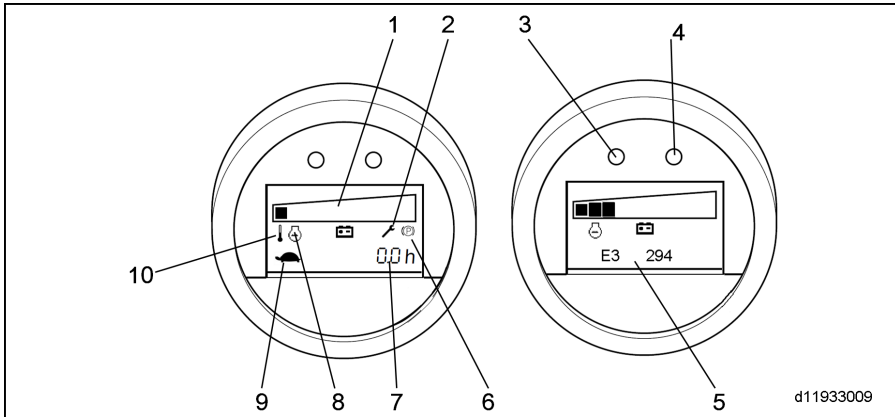

No.	Meaning	Explanation	Screen information/indication
1	10-bar symbol indicating battery charge	Fully charged:100% Low charge:10% Completely discharged:0%	10 bars remaining:charge level 91–100% 1 bars remaining:1–10% 1 flashing bar remaining:0% Note:in order to protect the battery, the display unit will show 0% remaining power when the battery is left with 20% power
2	Service reminder (red)	Flashing:less than 50 hours before next service Solid light:service interval exceeded	
3	Red indicator light	Solid light:indicates an error or warning	
4	Green indicator light	Off:indicates that the vehicle is switched off Solid light:indicates that the vehicle is switched on	
5	Error codes		Fault codes help service department engineers to correctly diagnose faults
6	Failure or brake worn (air gap)		Cannot operate vehicle

7	Hour meter	Indicates the vehicle's working hours	The hour meter commences counting when the vehicle starts working and performs functional operations When the hour meter is running, the hourglass flashes slowly The hour meter displays hours and minutes If the power supply is switched off, the time will be stored in the memory.
8	STOP alarm (red)	Multiple faults	Cannot operate vehicle
9	Creep speed travel	The LED graphic symbol will flash when travelling at creep speed.	
10	Temperature alarm (red)	Solid light: control module overheated	Stop the vehicle and wait a few minutes before running it again.

Electronic key (option)

Electronic key (option)

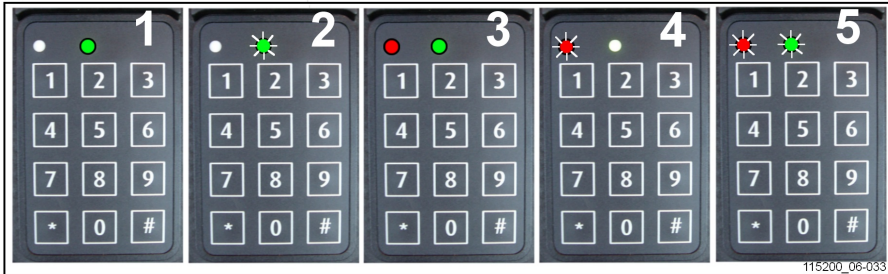

- | | | | |
|---|------------------------------|---|------------------------------------|
| 1 | Switch ON (operating mode) | 4 | Key fault or incorrect code |
| 2 | Switch OFF and awaiting code | 5 | Time delay of automatic switch-off |
| 3 | Programming mode active | | |

Operation	Enter	Status of LEDs	Comments
USE			
ON	*12345# (by default)	<ul style="list-style-type: none"> ○ red off ● continuous green (1) (correct PIN) ● red flashing ○ green off (4) (incorrect PIN) 	12345 default PIN
OFF	# (3 seconds)	○ red off ● green flashing (2)	Truck power off

PROGRAMMING (truck switch OFF only (2))			
ADMINISTRATOR CODE ESSENTIAL FOR ALL ELECTRONIC KEY SETTINGS	*00000000# (by default)	● continuous red ● continuous green (3)	Once the LEDs have gone out, the electronic key automatically reverts to "operating mode".
New operator code	*0*45678#	○ red off ● green flashing (2) (code accepted)	Example of new operator code: 45678
Allocating operator codes	*2*54321#	○ red off ● green flashing (2) (code accepted)	*2*: operator reference 10 options from 0 to 9
Deleting operator codes	*2*#	○ red off ● green flashing (2) (deletion accepted)	*2*: operator reference (between 0 and 9)
Modifying administrator codes	*9*12345678#	○ red off ● green flashing (2) (code accepted)	

PROGRAMMING (truck switch OFF only (2))			
Restoring the initial administrator code			To reactivate the default administrator code (00000000), please contact your agent or nearest dealer.
Activating the automatic switch-off	* * 2 * 1 #	● red flashing ● green flashing (5) (5 seconds before switch-off)	Power switches off automatically after 10 minutes (600 seconds by default) if the truck is not in use.
Setting the time delay of the automatic switch-off	* * 3 * 6 0 #	○ red off ● green flashing (2) (value accepted)	Example: automatically switches off after 1 minute (60 seconds) if not in use. Minimum setting = 10 seconds/maximum = 3000 seconds
Deactivating the automatic switch-off	* * 2 * 0 #	○ red off ● green flashing (2) (command accepted)	

RF device (optional)

Illustration of transponder chip



RF device (optional)

Illustration of reading device variant

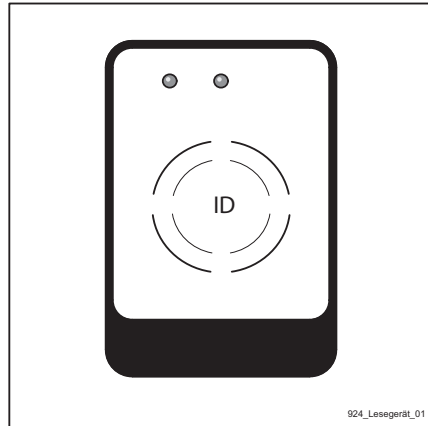

FleetManagerTM (reading device variant) consists of a housing (4) containing an integrated reading device (3).

LED 1 (1) and LED 2 (2) serve as a display element. Both LEDs cover the RGB colour space and can reproduce various colours.

In addition to the visual displays of the two LEDs, an integrated signal transmitter can sound corresponding signal tones.

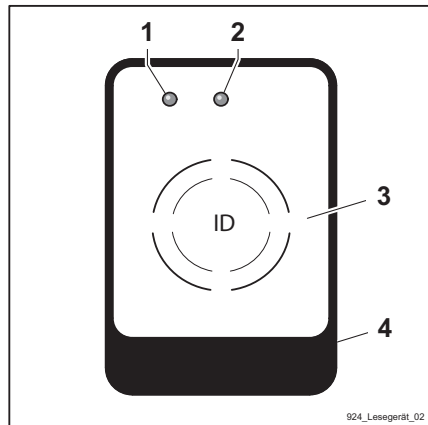

5

Use

Commissioning

Commissioning

Commissioning advice

We recommend that you avoid excessive use of the vehicle for the first 50 operating hours.

During the first few days or the first few operating hours, and after each wheel change, check the tightness of the wheel nuts to ensure that they are correctly seated before using the vehicle.



NOTE

Refer to the Maintenance section for wheel nut cross-tightening and torque.

Daily checks before driving

IMPORTANT:

Every time before starting work, it is essential to carry out checks on the operation of the vehicle, particularly the safety devices.

Before driving

People in the hazard area

Before starting the truck and while you are working, ensure that no one is in the hazard area. If anyone is in the hazard area, warn them well in advance. Stop working with the truck immediately if the people do not leave the hazard area despite the warnings.

Danger area

The hazard area is the area in which people are in danger from the tow truck movements, from its work equipment and from its trailers or from the load. The areas in which a load could fall or work equipment could lower or fall are also part of the hazard area.

Check the correct operation of the following devices:

- Forward/reverse travel function
- Electromagnetic brake function
- Automatic regenerative brake function
- Emergency stop switch function
- Horn function
- Operator presence switch
- Battery lock (only for models equipped with battery lock)

DANGER

Risk of death, injury and/or serious damage to the equipment.

If the vehicle malfunctions, immediately notify the relevant personnel and stop using the vehicle.

Dimensions of the traffic routes and manoeuvring areas ▷

	Turning radius values (Wa)
Type	Wa
LTX10, LTX20	1080 mm
LTX — T04	1660 mm

Country-specific regulations must be complied with.

Please make sure that there are no overly sharp bends, no excessively steep slopes and that no doors are too narrow or low along the truck's route.

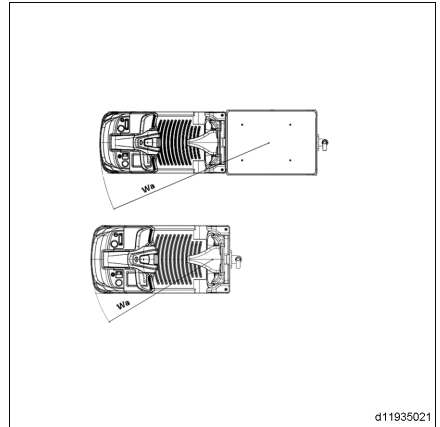

d11935021

Traffic route conditions

The traffic route surfaces must be sufficiently flat, clean and clear of fallen objects. Drainage channels, railway crossings and other similar items must be level and, if necessary, fitted with ramps so that the truck can cross without jerking.

There must be sufficient distance between the highest part of the truck or the load and the surrounding fixed installations. Consult the technical characteristics.

Rules regarding the traffic routes and the manoeuvring areas

Only traffic routes authorised by the operator or his agent may be used. Traffic routes must be obstacle free. Loads may only be discharged and stored in places designed for this purpose. The operator or his agent must ensure that no unauthorised person approaches the working area.

Hazards

Hazards on the traffic routes must be signalled by current road signs or possibly by additional warning notices.

Designation

Designation

Your truck is fitted with special equipment for use in cold stores. It can be used for two operating ranges and carries a cold store label.

The cold store equipment for the truck consists of using specialised oils (for the gears) suitable for cold stores.

Proper usage

Operating range 1: permanent use in areas with temperatures of $-5\text{ }^{\circ}\text{C}$ and for short periods of time down to $-10\text{ }^{\circ}\text{C}$. Parking outside the cold store.

Use

General

The change in temperature between the cold indoors and the heat outside causes condensation. This water can freeze when the truck goes back into the cold store and jam the moving parts of the truck. This is why the length of time the truck remains in the different temperature areas given below for the two operating ranges must be strictly adhered to.

The temperature of the traction batteries must never fall to the temperature of the cold store, otherwise they will stop working.

Prior to start-up

⚠ CAUTION

The truck must be dry and at operating temperature before being used in the cold store.

- Drive the truck for approximately 5 minutes and operate the brakes several times to ensure the truck operates safely.



Use

Operating range 1

Permanent use in areas with temperatures of $-5\text{ }^{\circ}\text{C}$ and for short periods of time down to $-10\text{ }^{\circ}\text{C}$.

Operating range 2

Alternating use indoors with temperatures down to $-32\text{ }^{\circ}\text{C}$ and outside with temperatures up to $+25\text{ }^{\circ}\text{C}$ for short periods of time even up to $+40\text{ }^{\circ}\text{C}$. The truck must not leave the cold area for more than 10 minutes, because this length of time is not long enough for the formation of condensation. If the truck stays outside for longer than 10 minutes, it must remain outside for long enough to allow the condensation to run away. This generally takes at least 30 minutes.

⚠ DANGER

If the condensation freezes in the cold store, the moving parts that have become jammed must not be freed by hand.

Parking

- Always park the truck outside the cold store.

⚠ CAUTION

The batteries must not remain discharged or unused in the cold store overnight.

- Charge the battery outside the cold store and use a spare battery.

Checks before initial use

Inspection item	Completion status	
	√	X
Dashboard settings		
Forward/reverse travel function		
Electromagnetic brake function		

Daily checks before use

Automatic regenerative brake function		
Emergency stop switch function		
Horn function		
Operator presence switch		
Battery lock (only for models equipped with battery lock)		

Daily checks before use

Inspection item	Completion status	
	√	X
Forward/reverse travel function		
Electromagnetic brake function		
Automatic regenerative brake function		
Emergency stop switch function		
Horn function		
Operator presence switch		
Battery lock (only for models equipped with battery lock)		

Checking the working environment

The places where the tow tractor is used must comply with the applicable regulations (condition of the ground, lighting etc.).

Before using the tow tractor, it is essential to check the working environment. This check can take the form of a visual inspection.

There must be no signs of leaking consumables under the tow tractor.

The battery compartment must be closed correctly and all additional equipment attached correctly.

The work area must be clear. The tow tractor's path must be free of obstacles and people.

The driver must be alert to anything that might prevent manoeuvres being carried out safely:

- There must be nobody near the tow tractor
- The driver must not use a mobile phone, an MP3 player or any other electrical equipment that could impair awareness of his/her surroundings
- There must be no signs of oil or grease on the floor

The driver must take care when transporting a load. The load dimensions can interfere with manoeuvres and restrict the field of vision. The speed of the tow tractor must also be reduced as it could tip over when braking or cornering.

Speed must be reduced when moving over obstacles to prevent the tow tractor from becoming unbalanced and vibrations in the driver's arms.

Operating instructions

The LTX10, LTX20 and LTX-T04 are for indoor use in non-hazardous atmospheres; the ambient temperature must be between -10°C and +40°C and the air humidity less than 95%.

The LTX10, LTX20 and LTX-T04 comply with the requirements of EN12895 on electromagnetic compatibility. Correct operation of the trucks can no longer be guaranteed if they are used in areas where the electromagnetic fields could exceed the thresholds specified by the standard.

The ground must be dry, clean and even. The resistance to flattening of the ground must be about 38 daN/cm².

For reasons of braking capacity and stability, the recommended maximum negotiable gradient over a short distance is limited to 5% (with loads) or 10% (without loads).

The truck can only handle a maximum cargo weight of 1 tonnes (LTX10), or 2 tonnes (LTX20) or 400/1000 kg (LTX-T04).



NOTE

The platform of LTX-T04 can load 400kg cargo, and at the same time, the truck can tow 1000kg cargo.

For uses other than those shown above, please consult our service engineers.

DANGER

Risk of serious injury and/or serious damage to the equipment.

Always adapt your driving to the ground conditions (uneven surfaces etc.), particularly hazardous working areas and the load.

CAUTION

Risk of deterioration and/or destruction of the equipment.

Always switch off the ignition and remove the key before leaving the truck.

Commissioning

⚠ DANGER

Risk of serious injury and/or serious damage to the equipment.

Always keep your hands on the controls, and switch off the power supply before touching moving parts and devices.

⚠ CAUTION

Risk of deterioration and/or destruction of the equipment

The undercarriage of this vehicle is designed to protect the driver's feet. However, the protective measures are only fully effective when the driver is wearing safety footwear.

⚠ DANGER

Risk to life and/or risk of serious damage to the equipment.

It is essential to comply with the rules on operation and safety described in the chapters "Driving with a trailer" and "Driving on a slope".

⚠ CAUTION

Risk of deterioration and/or destruction of the equipment.

The driver's feet must stay within the limits of the platform.

⚠ DANGER

Risk of serious injury and/or serious damage to the equipment.

Before setting off in forward or reverse travel, look carefully in the direction of travel to ensure that the manoeuvre can be carried out safely.

⚠ CAUTION

Risk of deterioration and/or destruction of the equipment.

The driver's platform must not be used to push loads sideways.

⚠ CAUTION

Risk of deterioration and/or destruction of the equipment.

Before using a side access vehicle, check that the battery is correctly locked.

⚠ DANGER

Risk of serious injury and/or serious damage to the equipment.

Do not use the platform or the trailers to carry passengers.

Commissioning

- Open the battery hood.
- Plug in the battery connector.
- Close the battery hood.
- Adjust the tiller height.
- Adjust the auxiliary seat height.

Emergency stop switch

- Raise the emergency stop switch (2).
- Turn on the power switch (1).
- The multifunction display screen (3) will illuminate; check the status of the vehicle.

i NOTE

Adjust your speed according to the route, the ground conditions and the load. Use the vehicle on a flat and hard surface.

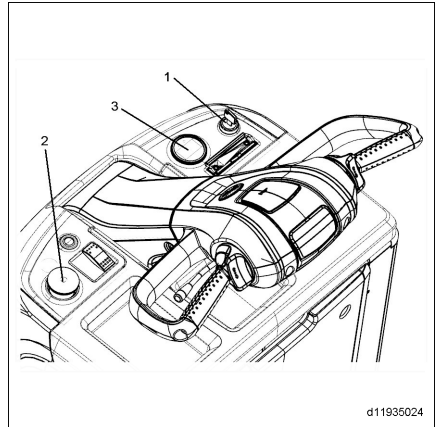

Emergency stop switch

- During normal operation, the emergency stop switch (1) must be pulled out.
- In case of danger, press down the button (1) to break the electrical circuit and apply the electromagnetic safety brake.

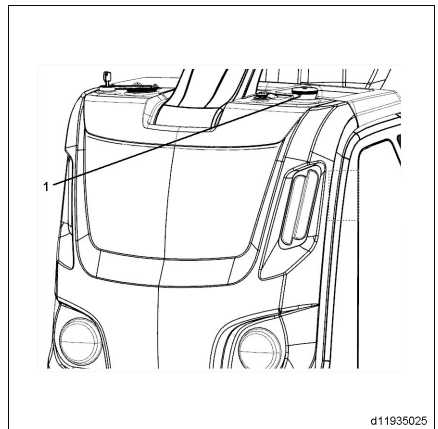

Determining the drive direction

Determining the drive direction

- The controls for direction of travel are:
- Forward travel (1) — towards the tiller
- Reverse travel (2) — towards the tow coupling

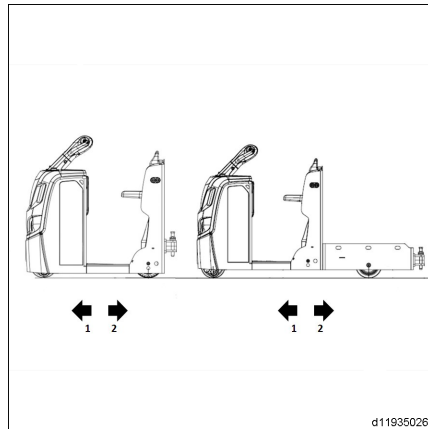

Forward/reverse travel

- Raise the emergency stop switch, turn on the power switch.



Forward travel

- Slowly press the drive switch forward with your thumb.
- The vehicle will move forward in the same direction as the direction of the drive switch.

CAUTION

Risk of damage to the components.

Do not press the switch on one side forward while pressing the switch on the other side backward.

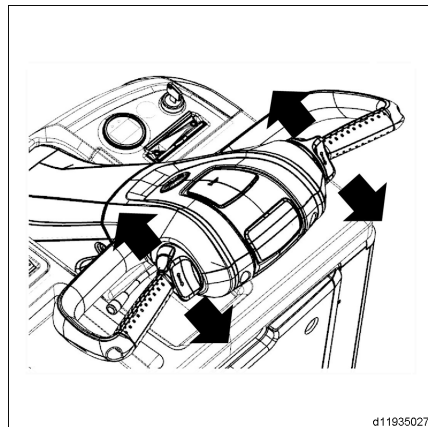

Reverse travel

- Slowly press the drive switch backward with your thumb.
- The vehicle will move backward in the same direction as the direction of the drive switch.

⚠ CAUTION

Risk of damage to the components.

Do not press the switch on one side forward while pressing the switch on the other side backward.

Steering unit

The steering for the LTX10, LTX20 and LTX-T 04 is controlled using the ergonomic tiller. ▷

⚠ DANGER

Serious risk of personal injury or damage to the equipment.

Never use the truck if the steering system is faulty.

⚠ DANGER

Serious risk of personal injury or damage to the equipment.

Sudden turns at excessive speed can cause the vehicle to overturn.

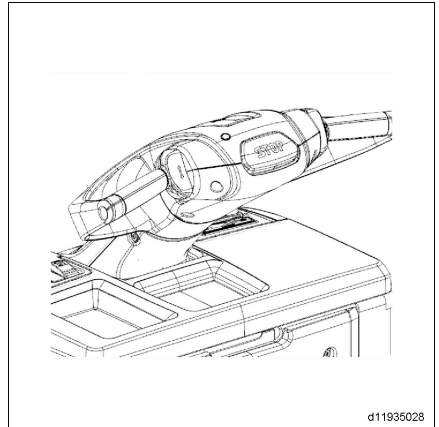

Steering directions in forward travel

- Turn the tiller clockwise — the truck should turn to the right.
- Turn the tiller anti-clockwise — the truck should turn to the left.

Stand-on/seated driving operation

⚠ CAUTION

The driver must only perform driving manoeuvres after making the following adjustments:

- Check the battery male connector is firmly attached
- Make sure the battery is fixed with fix device.
- Adjust the tiller height
- Adjust the auxiliary seat height.

Stand-on/seated driving operation

The low step and wide opening on both sides facilitate access to the driver's work station. ▷

The suspended platform, non-slip floor plate and height-adjustable auxiliary seat and tiller provide an extremely comfortable driving experience.

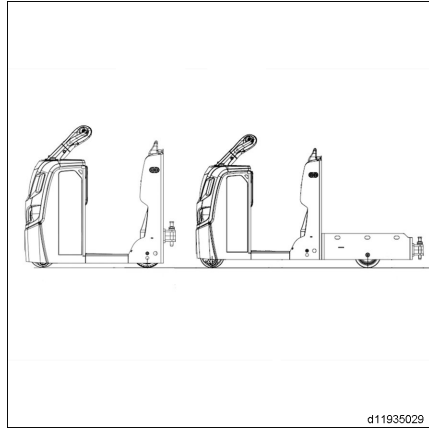

Using the auxiliary seat

- When entering the vehicle, fold out the auxiliary seat by pulling it downward. ▷

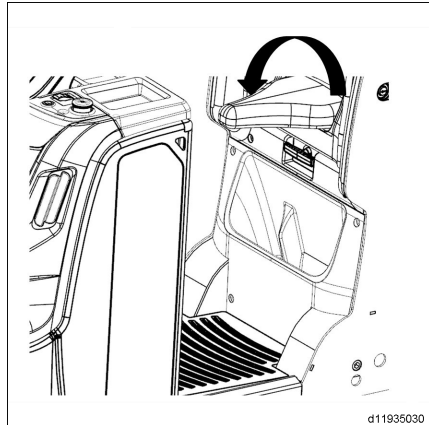

- The auxiliary seat height can be adjusted to provide a suitable driving position. ▷

To adjust the auxiliary seat height:

- Pull out the handle in the direction of the arrow.
- Adjust the auxiliary seat height by pressing down on the auxiliary seat while standing beside the vehicle.
- Once the auxiliary seat is suitably positioned, release the handle so that it returns to its original position.



NOTE

The handle must fully return to its original position with the stop pin engaged in the hole.

CAUTION

Risk of an accident.

Do not adjust the auxiliary seat height while the vehicle is travelling.

- Sliding rail for raising and lowering the auxiliary seat. ▷

WARNING

Risk of hurting fingers.

Be careful when adjusting the auxiliary seat height, don't put the fingers into the rail of the auxiliary seat.

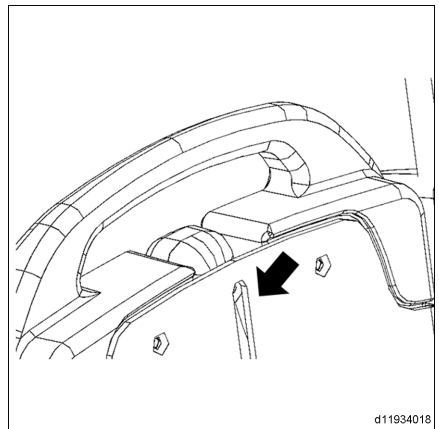
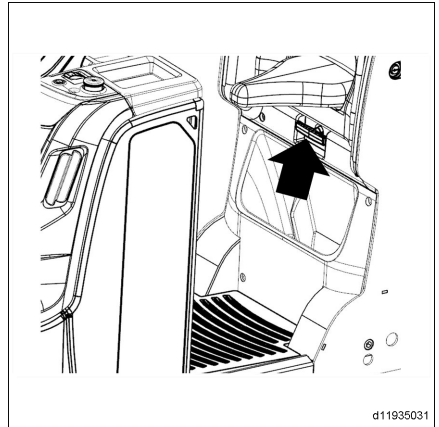

Stand-on/seated driving operation

Adjusting the tiller angle

The angle of the tiller can be adjusted to make driving more comfortable. ▷

To adjust the tiller angle:

- Press the button indicated by the arrow
- While holding down the button, adjust the tiller angle by hand
- Once the tiller is suitably positioned, release the button to secure the tiller



NOTE

Do not operate the vehicle if the tiller is at a vertical or near vertical angle. Only position the tiller at a vertical angle to facilitate battery replacement.

CAUTION

Risk of hurting the hand.

It's forbidden to put the hand under the tiller when adjust the angle of the tiller.

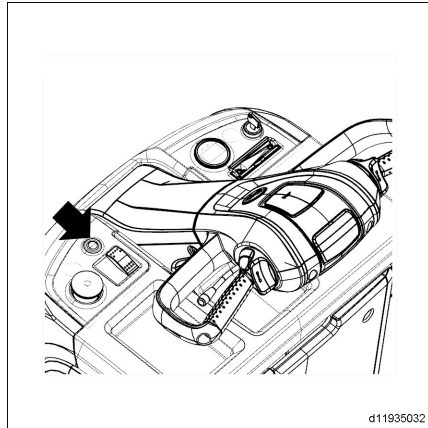

d11935032

Driving position

The driver should adopt a standing or seated driving position. ▷

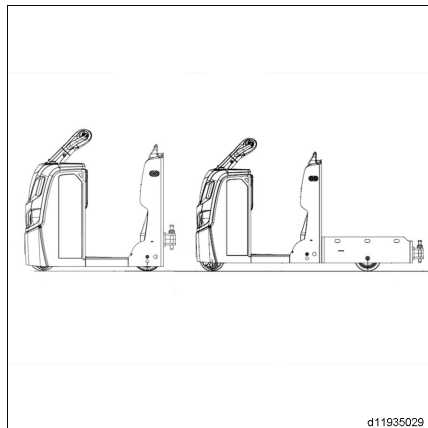

d11935029

Driving on a slope

NOTE

We recommend that you do not use the vehicle on a slope greater than 5% (with load) or 10% (without load) in order to avoid damaging the motor, brake and/or battery.

Exercise extreme caution when using the vehicle on a slope:

- Do not drive on slopes that exceed the vehicle's maximum allowable gradient. (See Technical Datasheet)
- Make sure that the floor is clean, flat, non-slip and uncluttered.

Ascending a slope

Always travel in forward gear when ascending slopes with a load. Unladen vehicles can ascend slopes in forward or reverse gear.

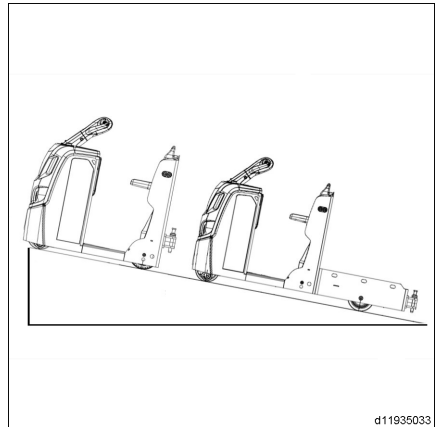

Driving on a slope

Descending a slope

Always travel in forward gear when descending slopes with a load. Unladen vehicles must descend slopes in forward gear (i.e. with the tow coupling facing uphill.)

⚠ DANGER

Risk of death, injury and/or serious damage to the equipment.

- Slow down and brake very gradually when travelling downhill.
- Never park the vehicle on a slope. Never make a U-turn or take shortcuts on a slope. The driver must always drive more slowly when working on a slope.

⚠ CAUTION

Driving on slopes greater than 5% (with load) or 10% (without load) is prohibited due to limited braking capacity.

For safety reasons if the maximum speed is exceeded, e.g. when operating on a slope over a long distance or on a very steep slope, the electromagnetic brake will be activated automatically.

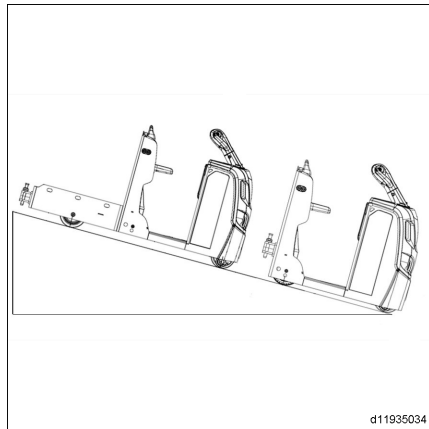

d11935034

Stopping and starting on a slope

If you have to stop and restart on a slope, follow the procedure below:

Stopping on an uphill slope:

- Release the drive switch on the tiller, the vehicle will decelerate to a standstill
- Turn off the power switch

Stopping on a downhill slope:

- Release the drive switch on the tiller, the vehicle will decelerate to a standstill
- Turn off the power switch

Starting on a slope:

- Turn on the power switch
- Push the drive switch on the tiller forward or backward depending on the required direction of travel
- The electromagnetic brake will release automatically and the vehicle will start moving

i NOTE

If you need to stop the vehicle more quickly when travelling downhill, press the drive switch into reverse, thereby using reverse braking to increase the braking force.

Brake, horn and lighting

Electromagnetic safety or parking brake system ▷

The electromagnetic brake is applied automatically in the following circumstances:

- When the drive direction switch (1) fails
- When the operator leaves the driver's platform (3)
- When the drive direction switch (1) is in the centre position and the vehicle is stationary
- When the emergency stop switch (2) is operated

Brake

- When the forward/reverse switch (1) on the tiller is released, the counter-current regenerative brake is applied until the vehicle comes to a stop.

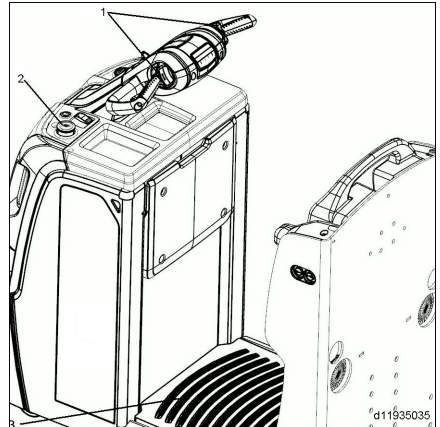

Reverse braking

Reverse braking can be performed by changing the direction of travel:

- When the vehicle is moving, press the drive direction switch (1) in the opposite direction to the vehicle's direction of travel until the vehicle comes to a stop.
- Release the drive direction switch (1).

Coupling

Horn

- To sound the horn, press the horn button (6).



NOTE

Because the vehicle has a mechanical steering unit, it may not be possible to turn corners safely with one hand unless the operator has sufficient arm strength. Therefore, to avoid the above situation when travelling, slow down almost to a standstill when approaching corners and use the horn to alert pedestrians in blind spots.

Lighting (optional)

To use the headlights, tail lights and/or hazard warning lights, press the corresponding button on the control panel.



NOTE

Because the vehicle has a mechanical steering unit, it may not be possible to turn corners safely with one hand unless the operator has sufficient arm strength. Therefore, to avoid the above situation when travelling, turn the lights on or off before driving the vehicle.

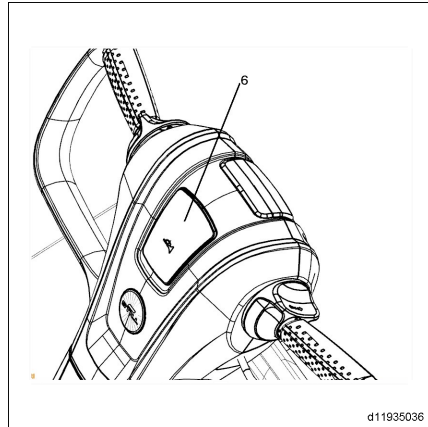

d11935036

Coupling

There are two types of the hook:

- a steel cable pulling device that can be controlled automatically from the driver's compartment. (A)
 - a rigid rod coupling. (B)
- To release the coupling, manually raise the cable handle upwards (1) or lift the tie rod (2).

WARNING

Risk of serious personal injury and/or equipment damage.

Do not operate the tow coupling unless the vehicle is parked and the brake is engaged.

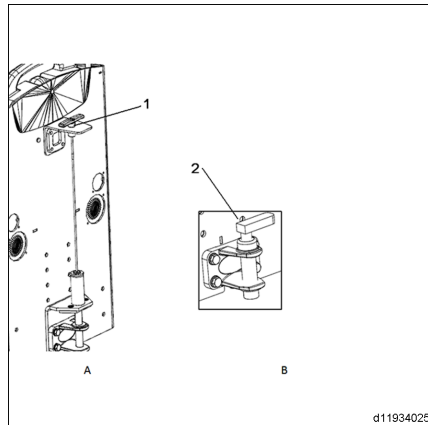

d11934025

⚠ WARNING

Risk of serious personal injury and/or equipment damage.

Do not operate the tow coupling with the unauthorised coupling pin.

Coupling the trailer

Checking the trailer

- Before connecting the trailer to the tow tractor, check that the coupling pin hole of the trailer matches the pin hole on the tow tractor.
- Make sure the trailer brake (if present) is engaged, or chock the wheels with wooden blocks to prevent the trailer from moving.
- Reverse the tow tractor towards the trailer, ensuring that the tow coupling and tow bar are aligned.

⚠ CAUTION

Risk of damage to the equipment.

Before loading, ensure that the total weight of the load and the trailer does not exceed the maximum specified weight.

⚠ CAUTION

Risk of damage to the equipment.

When coupling or uncoupling the trailer, make sure that the tow tractor and trailer are positioned on a level surface. Make sure that the trailer and tow tractor are in neutral gear and engage the parking brake.

⚠ CAUTION

Risk of damage to the equipment.

Before coupling the trailer to the tow tractor, check that the coupling pin hole of the trailer matches the coupling pin hole on the tow tractor.

Coupling the trailer

WARNING

Risk of serious injury and/or serious damage to the equipment.

During the coupling process, there must be no one between the tow tractor and the trailer.

Be sure to use the tow tractor's inching function to complete the coupling operation.

DANGER

Risk to life and/or risk of serious damage to the equipment.

Make sure that the tow tractor and trailer are correctly coupled.

Check the tow coupling by moving the vehicle slowly

The vehicle's inching function can be controlled with the driver dismounted from the work station.

CAUTION

Never place your feet too close to the vehicle when connecting the tow coupling.

Wear safety footwear at all times.

- Reverse the tow tractor towards the front of the trailer.
- Stand on the left- or right-hand side of the tow tractor.

- Press the forward or reverse buttons shown in the figure, depending on the required direction of travel; the vehicle will start moving.
- Release the button to stop the vehicle.

i NOTE

On LTX-T04 models, both sides of the vehicle are equipped with one forward button only.

Coupling the trailer

- Make sure that the trailer remains stationary. If the trailer is equipped with a braking device, make sure it is engaged. If necessary, use wooden blocks to chock the wheels.
- Lift the coupling pin.
- Operate the tow tractor so that the coupling pin hole of the trailer is aligned with the coupling pin hole on the tow tractor.
- Release the coupling pin so that it returns to its original position and locks the trailer in place.

⚠ CAUTION

Be careful not to get your fingers caught.

When coupling the trailer, wear protective gloves and pay attention to where you place your hands.

Uncoupling the trailer

- Make sure that the trailer remains stationary. If the trailer is equipped with a braking device, make sure it is engaged. If necessary, use wooden blocks to chock the wheels.

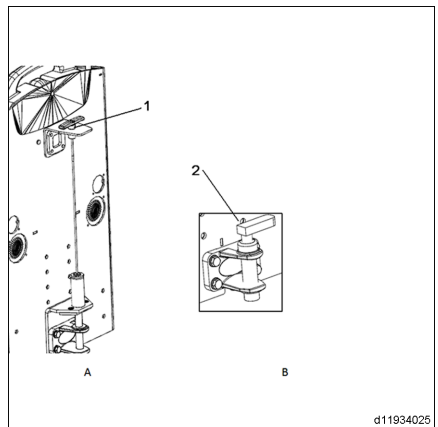
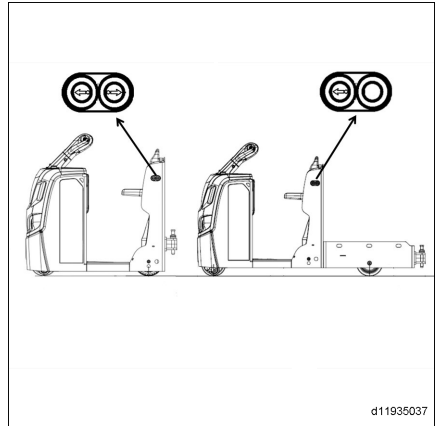

Driving the truck with cargo

- Lift the tow tractor's coupling pin.
- Uncouple the trailer.

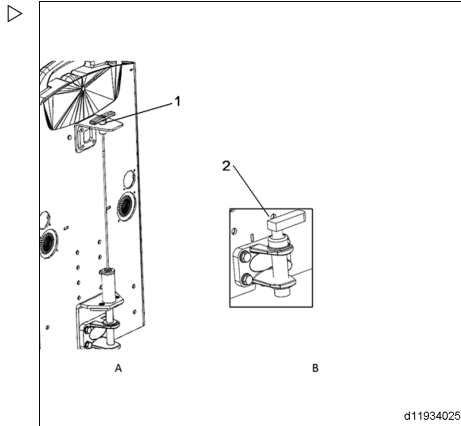

Driving the truck with cargo

- Always keep the vehicle facing forward when driving; do not travel across a slope or make a U-turn.



NOTE

Reverse travel must only be used for depositing a load; since visibility in this direction is restricted, you should only travel at very low speed.

Use a spotter in the following situations:

- When coupling multiple trailers
 - When transporting a load that overhangs the side of the trailer
 - When visibility is poor
- In order to negotiate corners smoothly, consider the type of trailer, the turning radius and the width of the trailer.
 - When approaching your destination, reduce speed in advance to stop the vehicle safely.

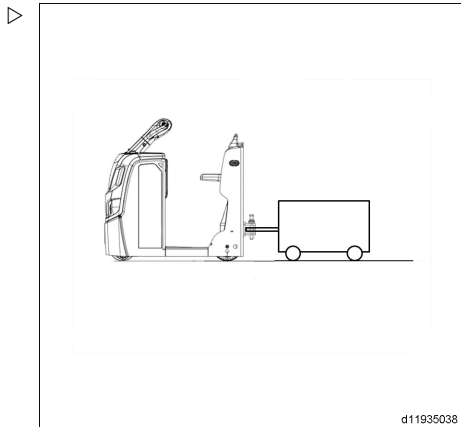

⚠ DANGER

Risk to life and/or risk of serious damage to the equipment.

Transporting passengers on the tow tractor or the trailer is prohibited.

⚠ CAUTION

Risk of serious injury and/or serious damage to the equipment.

Ensure that the load is securely stacked on the trailer with an even weight distribution and that the weight of the tow tractor and trailer is within the tolerance range.

⚠ CAUTION

Risk of serious injury and/or serious damage to the equipment.

Always comply with local traffic regulations when driving on public roads.

⚠ CAUTION

Risk of serious injury and/or serious damage to the equipment.

Slow down when negotiating corners; cornering too fast can cause the vehicle to overturn.

Drive the LTX-T04 with cargo on the platform

- When drive the LTX-T04 with cargo on the platform, use rope through hole to fix the cargo on the platform.

⚠ CAUTION

Risk of serious injury and/or serious damage to the equipment.

Ensure that the load is securely stacked on the platform with an even weight distribution is within the tolerance range.

Precautions before leaving the vehicle

- Turn off the power switch and remove the key.
- If the truck will not be used for a long time, press down the emergency stop switch and disconnect the battery connector.

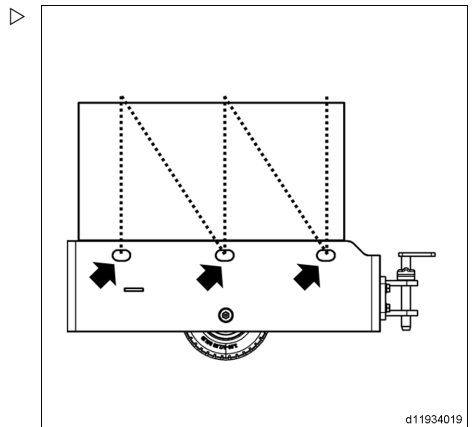

Transporting the truck

⚠ CAUTION

Risk of damage to the equipment.

Park the vehicle on a level surface away from busy traffic routes and protect it from moisture.

Transporting the truck

Lifting the truck

- Lift the truck safely with dedicated lifting gear. ▷
- Position the truck on the suitable place and lower the truck.

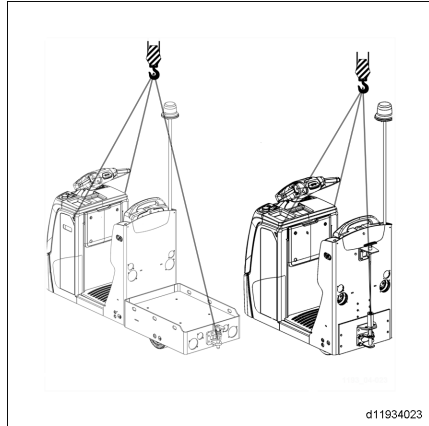

Transporting the truck

Before transporting the truck, please make sure the wheels are blocked by wood blocks in the right direction and the truck is tied from the right points with two slings. ▷

The front tie points are the hook holes in both side of the battery box shown in the illustration, and the rear tie point is the tow coupling.

⚠ CAUTION

During transportation on a lorry or truck, always fasten the truck securely.

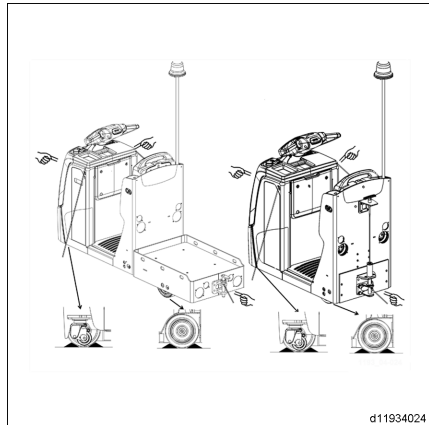

Truck storage

Measures to be carried out before storing a forklift truck

If the tow tractor is taken out of operation for over two months, the tow tractor must be parked in a well-ventilated, frost-free, clean and dry room, and the following measures must be carried out.

Measures to be carried out before storing a tow tractor

- Thoroughly clean the tow tractor.
- Check the brakes.
- Apply a thin layer of lubricating oil or lubricating grease to the surface of all unpainted components.
- Lubricate the tow tractor.
- Check the battery charge status and charge the battery if needed.
- Detach the battery connections and clean the battery. Apply non-acidic lubricating grease to the battery terminal. (Refer to the

"User Manual" provided by the battery manufacturer)

- Spray all exposed connectors with a suitable contact spray.

CAUTION

Jack up the tow tractor so that the wheels do not touch the ground in order to prevent the tyres from warping.

NOTE

Do not cover the tractor with a plastic tarpaulin as this will increase the amount of condensation that forms.

NOTE

Please contact the manufacturer for any relevant information if you need to decommission the tow tractor for more than six months.

Putting the tow tractor back into service

- Thoroughly clean the tow tractor.
- Lubricate the tow tractor.
- Apply a layer of non-acidic lubricating grease to the battery terminals.
- Check the battery charge status.
- Check the hydraulic oil. Replace the hydraulic oil if too much water is present.
- Check the tyre pressure.
- Conduct a routine inspection of the tow tractor before putting the tow tractor into use.
- Return the tow tractor to service.

Disposal of old trucks

Disposal of old trucks

The disposal of old trucks is regulated in directive 2000/53/EC from the European Parliament and Council.

We therefore recommend having this work carried out in an approved recycling plant. If you would like to carry out this work yourself, you must obtain approval from the relevant authorities as per articles 9, 10 and 11 of directive 75/442/EEC.

In addition, the following minimum requirements must be observed:

- The locations in which old trucks are stored before treatment must be areas suited to this task with impervious surfaces. These areas are also to be equipped with collection devices and separators for leaking fluids and degreasing cleaning materials
- The locations for treatment must be areas suited to this task with impervious surfaces. These areas must also be equipped with collection devices and separators for leaking fluids and degreasing cleaning materials. Suitable storage areas must be available for disassembled and partially oil-

smearing parts, as well as for tyres including fire protection measures. Suitable storage tanks for fluids such as fuel, AdBlue® (urea solution), engine oil, hydraulic oil, cooling fluid and fluids from air conditioning systems must also be provided

- In order to dispose of harmful substances from the old trucks, the batteries and LPG container must be removed. The following must also be removed, collected and stored separately: fuel, AdBlue® (urea solution), engine oil, cooling fluid, hydraulic oil and fluids from air conditioning systems
- The following parts are to be collected separately and recycled: catalytic converters, metal components containing copper and aluminium, tyres, large plastic components (consoles, fluid containers) and glass



NOTE

The operating company is responsible for adherence to the directives as well as additional country-specific regulations.

6

Maintenance

General maintenance information

General maintenance information

General

The following instructions contain all the information required for servicing your truck. Carry out the various maintenance tasks in compliance with the service plan. This will ensure your truck is reliable and in good working order and that the warranty remains valid.

Service plan

Maintenance work must be carried out according to the hour meter. Please consult the truck's maintenance plan.

The service plan is followed by advice to facilitate work.

Maintenance intervals must be reduced if the truck is used under extreme conditions (extreme heat or extreme cold, large quantities of dust).

Quality and quantity of lubricants and other ingredients

Only lubricants and other ingredients specified in this manual are authorised for use during maintenance work.

Lubricants and other ingredients required for truck maintenance are listed in the table of maintenance characteristics.

Never mix different qualities of grease or oil. If it is absolutely necessary to change brands, make sure that you rinse thoroughly beforehand.

Before changing any filters, clean the surface and area around the part thoroughly.

All containers used to pour the oil must be clean!

Staff training and qualifications for maintenance and repairs

Only qualified and authorized staff may carry out the maintenance. The annual inspection must be performed by an expert. The expert must provide his opinion and safety assessment irrespective of the internal and financial circumstances of the company. Only the safety aspect is decisive. He must have adequate knowledge and experience to assess the state of the vehicle and the effectiveness of the protective devices in accordance with the rules of technology and the basic principles of fork trucks.

Battery maintenance personnel

Batteries can only be recharged, maintained and changed by specially trained personnel who follow the manufacturer's instructions for the battery, the battery charger and the truck. Follow the battery maintenance instructions and the battery charger operating instructions.

Services not requiring special qualifications

Simple maintenance operations such as checking the battery electrolyte level can be carried out by persons with no special training. A qualification such as that outlined above is not necessary. Refer to the maintenance section of this manual for further information.

Ordering spare parts and wear parts

Spare parts are supplied by our after-sales service. Refer to the parts list for the required ordering information.

Only use spare parts recommended by the manufacturer. Unauthorised spare parts may increase the risk of accidents due to faults relating to quality or incorrect choices. Anyone who uses non-compliant spare parts is entirely responsible in the event of an accident.

General maintenance information

Recommended lubricants

CAUTION

Damage to equipment if non-recommended lubricants are used.

Only use recommended lubricants. Only the lubricants listed below are approved by the manufacturer. Do not mix lubricants. If in doubt, please contact the After-Sales Service Centre.

Transmission oil

Recommended oil:

SAE 85W 90 API GL4

Multi-purpose grease

Lithium soap grease with EP agents and MoS 2 **KPF 2N - 20** complying with the standard DIN 51825.



ENVIRONMENT NOTE

Used oil must be stored safely until it is disposed of in compliance with environmental protection measures. No one should have access to it. Do not dispose of used oil in drains or allow it to penetrate soil.

Technical inspection and maintenance characteristics

Unit	Item/lubricant	Quantity/setting/rated value
Transmission gear	Transmission gear oil	1.3 L
Drive wheels	Wheel mounting nuts	80 N.m
Castor wheels	Wheel shaft screw	20 N.m
Support wheel	Wheel shaft screw	200 N.m (for tow tractor) / 250 N.m (for platform tractor)
Traction motor	fuse	125 A
Control cable	fuse	10 A
Battery	Distilled water	As required
Hinge points	Lithium soap grease	As required

Safety regulations for maintenance

Safety regulations for maintenance

Safety measures for maintenance and repair

To prevent accidents during maintenance and repair, perform all necessary safety measures such as:

- Ensure that the truck is secured against inadvertent movement or accidental starting (disconnect the battery connector).

Work on the electrical equipment

Work on the electrical equipment of the pallet stacker is only allowed with the electrical system de-energised. Function checks, inspections and adjustments on live parts may only be carried out by trained and authorized staff under observance of suitable precautions. Rings, metal bracelets, etc must be removed before working on electric components.

To prevent damage to electrical equipment with electronic components such as an electronic travel control, remove them from the vehicle before doing any electric welding.

Modifications in the electrical system are only permitted with our approval.

Safety devices

Refit and check all safety devices for proper operation after maintenance and servicing.

Settings

Retain the vehicle-specific settings when repairing and replacing electric components. They are specified in the appropriate sections.

Daily checks before starting work

Checking the travel direction control function

- Step onto the driver's platform.
- Raise the emergency stop switch (1) and start the vehicle.
- Carefully operate the forward or reverse travel switch (2).
- The vehicle will travel forward or backward, the travel speed depends on how far the drive switch (2) is pushed.

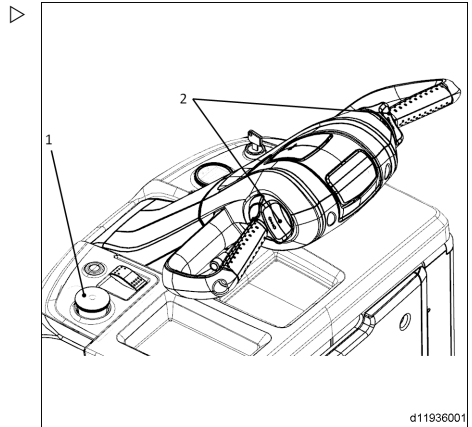

Checking the brakes

⚠ CAUTION

Do not drive the vehicle if the brake system is faulty.

Contact an authorised dealer or service engineer if a fault of any kind is discovered in the braking system.

Daily checks before starting work

Automatic braking

- Start the machine moving.
- Release the drive switch (1).
- Press the "STOP" button (2).
- The vehicle will come to a stop.

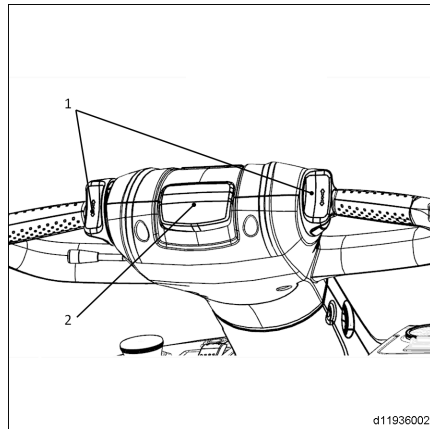

Brake the vehicle by reversing the direction of travel

- Start the machine moving.
- Push the drive direction switch (1) in the opposite direction to the direction of travel until the vehicle comes to a stop.
- Release the drive direction switch (1).

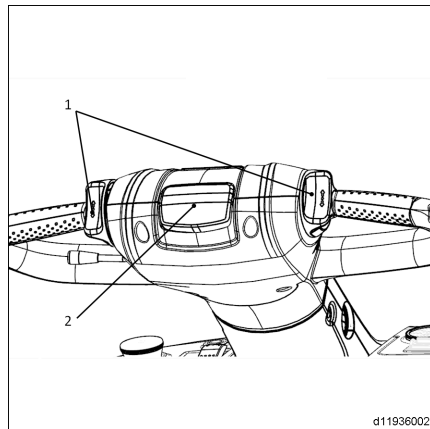

⚠ CAUTION

Risk of personal injury or destruction of the machine.
Carefully test the brake at low speed in a safe, open area free from traffic.

Parking brake

The parking brake is applied automatically if one of the following conditions is met:

- The driver leaves the operating platform (3)
- The power switch is off (4)
- The travel switch is released and the vehicle slows to a standstill (2)
- The emergency stop switch (1) is pushed

NOTE

A switch located under the foot plate of the driver's platform detects whether the driver is in the driver compartment or not.



d11936003

Testing the steering unit

- Drive the vehicle forwards slowly.
- Turn tiller clockwise — vehicle should turn to the right.
- Turn tiller anti-clockwise — vehicle should turn to the left.
- Turn tiller to middle position — vehicle should travel in a straight line.

NOTE

Stop the vehicle if the steering system is faulty.

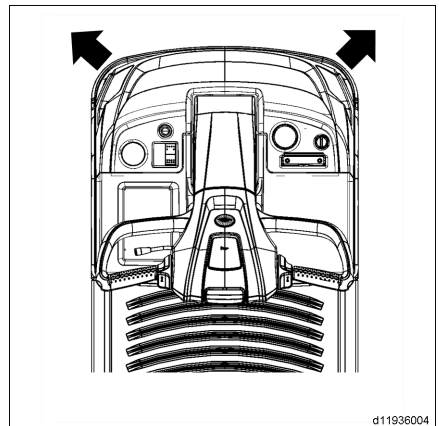

d11936004

CAUTION

Risk of destroying the machine.

Please contact an authorised dealer or service engineer if a fault of any kind is discovered in the steering system.

Testing safety devices

CAUTION

Do not drive a vehicle that has a faulty safety device.

Please contact an authorised dealer or service engineer if a fault of any kind is discovered in the safety devices.

Daily checks before starting work

Emergency stop switch

- Push the emergency stop switch (1), the vehicle's power supply should shut off; ▷
- The electrical control system and motor power supply should shut off;
- The electromagnetic brake should brake the vehicle;
- Pull up the emergency stop switch (1) to re-connect the vehicle's power supply;
- The vehicle is supplied again and all the functions are available.

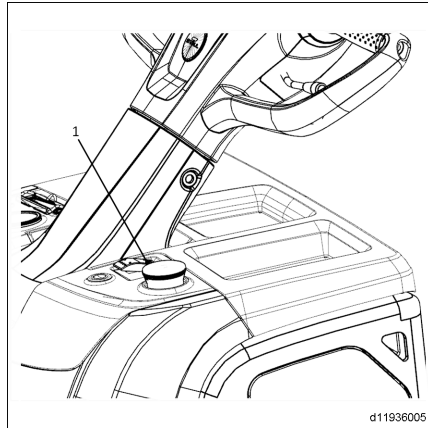

Horn

- Push the horn switch (6). ▷
- The horn should sound.

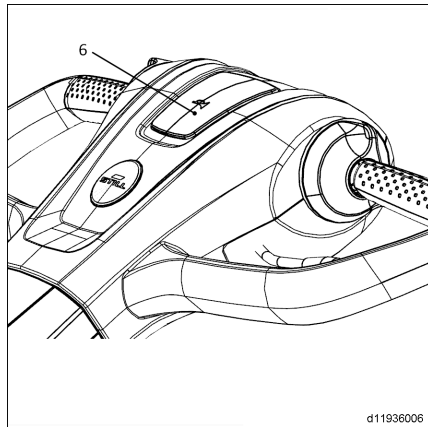

Checking the battery charging status

⚠ DANGER

Risk of death, injury and/or damage to equipment.

The battery must be charged and serviced in accordance with the instructions provided with the battery and the battery charger (if an external battery charger is used).

⚠ CAUTION

Risk of death, injury and/or damage to equipment.

The electrolyte contains sulphuric acid, which is a hazardous product. Wear gloves and goggles when working on the battery. In case of contact with eyes or skin, rinse immediately with plenty of clean water, then seek medical advice if the situation is severe. Charging the battery releases hydrogen, which creates an explosive mixture when mixed with oxygen. Therefore do not create sparks, do not smoke and keep naked flames away from a battery which is being charged or has recently been charged. To avoid the accumulation of hydrogen, charge the battery in a well-ventilated place and keep the battery hood open whilst charging. Do not place metal objects on the battery: there is a risk of creating a short-circuit.

- Before replacing the battery, check whether the battery is able to charge properly. ▷
- Plugging in the battery connector.
- Pull up the emergency stop switch (2) to power on the vehicle.
- Check the battery charge status on the multifunction display (3).

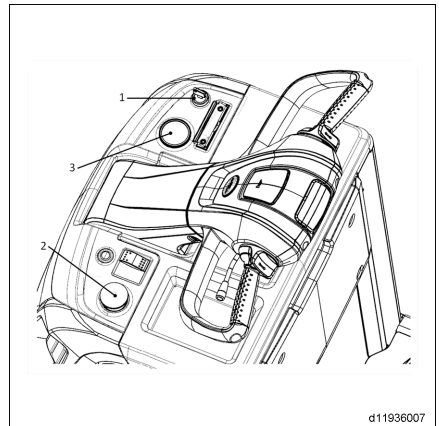

Daily checks before starting work

Opening the battery hood

- Stop the vehicle.
- Turn off the key switch (1).
- Push the emergency stop switch (2).
- Pull the battery hood out towards the auxiliary seat and remove the hood (3).



NOTE

It's better to wear protective gloves when operate the battery hood.



NOTE

Beware of getting your hand caught.

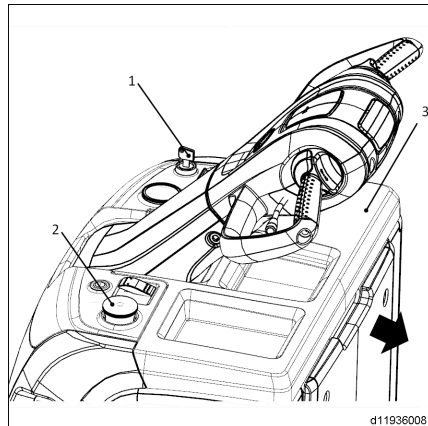

d11936008

Plugging in/unplugging the battery connector

Unplugging the connector

- Stop the vehicle and turn off the power switch.
- Open the battery hood.
- The battery connector is located at the side of the battery.
- Pull out the connector handle to disconnect it.

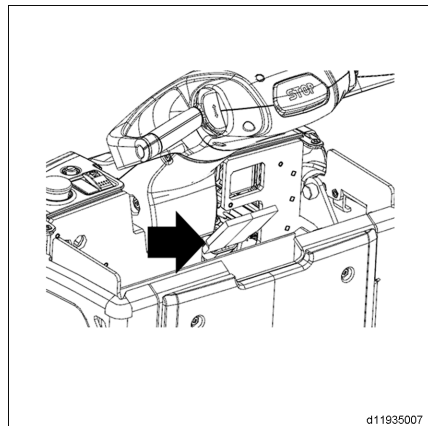

d11935007

Plugging in the connector

- Check that the connector is the right way round.
- Plug the connector plug into the socket.

⚠ CAUTION

Arcing may occur when the connector makes contact, with significant risk of electrical damage.

Do not plug in the connector unless the vehicle is powered off. Regularly check the state of the connector contact and replace it immediately if there is arcing damage or charring. Strictly adhere to the polarity signs (positive and negative) on the battery polarity. Never reverse the polarity. There are keying pins on the plug and socket to help you determine the direction of contact. These keying pins can eliminate the risk of inserting the plug the wrong way round.

Checking the condition of cables, terminals and battery connector

- Make sure that the cable insulation is not damaged and that the connector shows no signs of heating.
- Check that the positive and negative output line terminals are not sulphated (presence of white salt).
- Check the condition of the connector contact and keying pins.
- Check the condition of the locking tab on the battery connector.

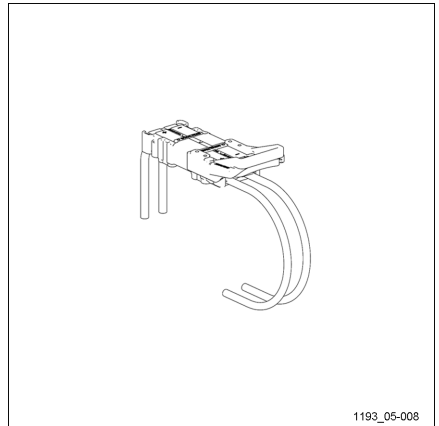
**⚠ CAUTION**

Risk of serious accidents.

If you discover that the cables, terminals and/or battery connector are defective, stop using the vehicle immediately and contact an authorised dealer or service engineer.

Removing/replacing the battery

NOTE

i NOTE

When handling batteries, make sure that all lifting equipment used (crane, hoist, slings, hooks, vehicles, handling devices) is sufficient for the weight of the battery.

Daily checks before starting work



NOTE

If installing a spare battery, make sure that the specifications of the spare battery (weight, size, voltage, capacity, connector socket) match those of the original battery. Refer to the vehicle rating plate to find out the maximum and minimum weight capacities.

⚠ CAUTION

Batteries are heavy and easily damaged; handle them with care.

The wearing of gloves is recommended.

⚠ CAUTION

Beware of pinching your fingers when removing and fitting the battery.

Keep your fingers away from moving parts to avoid any risk of trapping.

⚠ CAUTION

There is a risk of damaging the machine.

Before using the vehicle, make sure that the battery connector is securely connected and locked.

⚠ CAUTION

There is a risk of damaging the machine.

Before using the vehicle, make sure that the screws on battery fix device is secured.

Changing the battery using a hoist

- Switch off the truck and press the emergency switch.
- Open the battery hood.

- Unplug the battery connector.

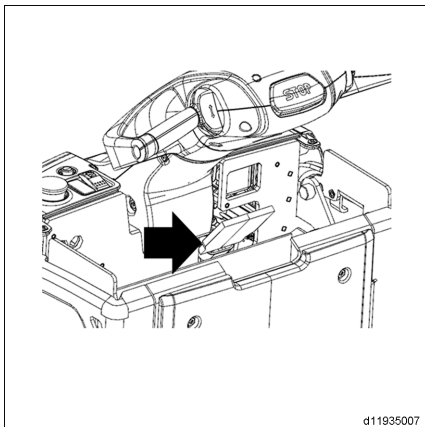

- Unscrew the screws(1) of the battery fix device on both sides.

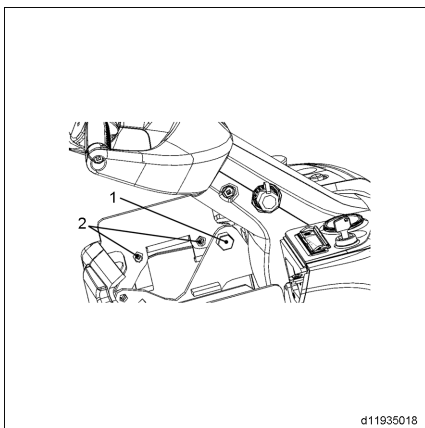

Daily checks before starting work

- Lift up the battery fix devices on both sides. ▷

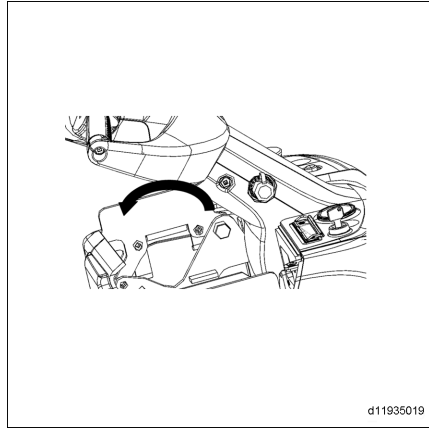

- Attach the hoist hook to the battery lifting eyes. ▷
- Carefully controlling the hoist, position the battery in the specified location.
- To install the replacement battery, perform the above procedure in reverse order.

Side access battery: changing the battery using a moveable support

- Switch off the truck and press the emergency switch.
- Open the battery hood.

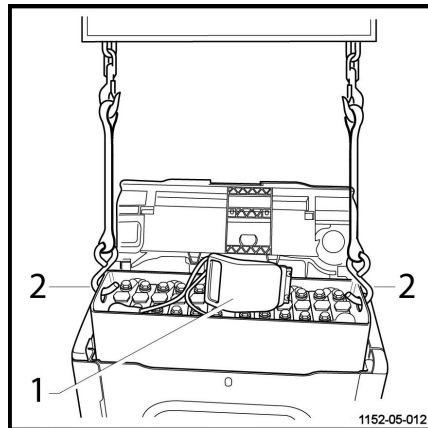

Daily checks before starting work

- Unplug the battery connector.

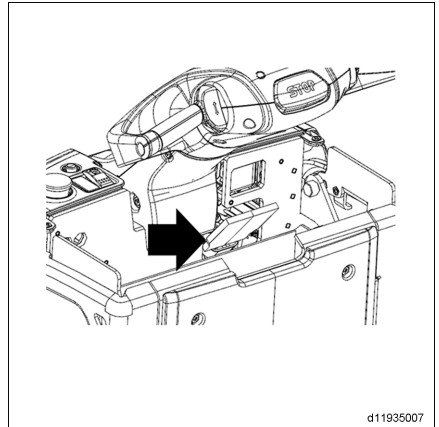

- Unscrew the screws(1) of the battery fix device on the battery removed side.

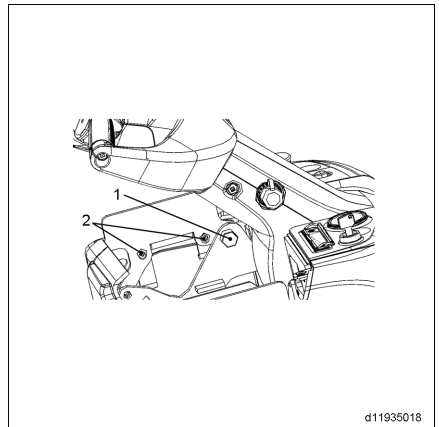

Daily checks before starting work

- Lift up the battery fix devices on the battery removed side. ▷

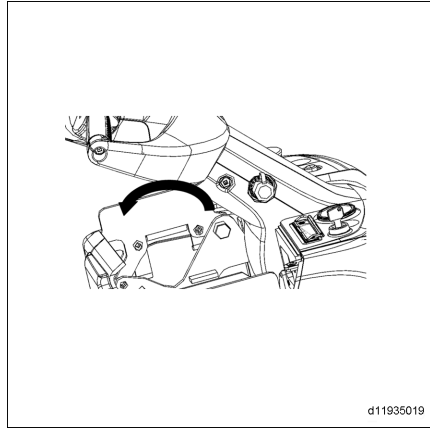

- Unscrew the screws(2) of the side panel. ▷

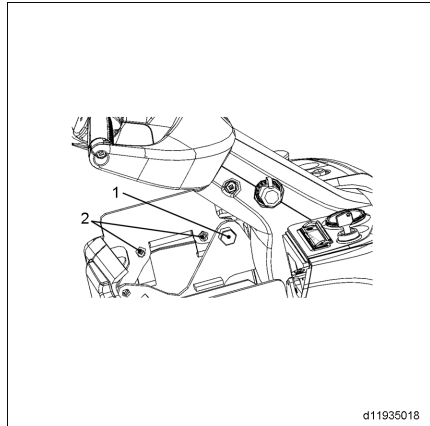

Daily checks before starting work

- The side panel is inserted on a slot. Remove the side panel.

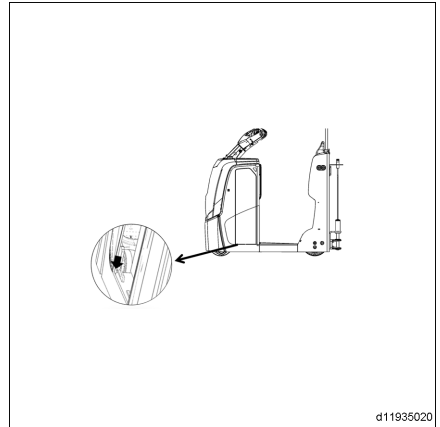

- Push the moveable support to the side, and keep the moveable support close to the truck.

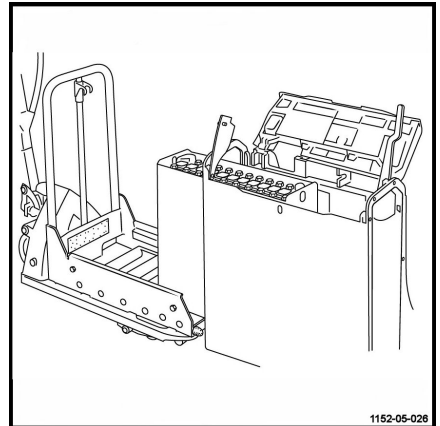
**NOTE**

Make sure that the wheel of the moveable support are locked when using the moveable support to replace the battery. Be sure that the moveable support is fixed when replacing the battery.

- Lock the wheels of the moveable support.
- Push the battery which is need to be replaced to the moveable support.
- Transport the battery to the charging station and transport the full charged battery to the side of the truck.
- To install the replacement battery, perform the above procedure in reverse order.

Maintenance plan as required

Maintenance plan as required

Cleaning

Cleaning the tractor



NOTE

Before cleaning the tow tractor, disconnect its power supply. Steam cleaning equipment or products with a strong degreasing effect should be used with great care, as they may dilute the grease used to lubricate bearings or cause electrical components to become damp. Take the necessary protection measures.

CAUTION

Cleaning may lead to deterioration or destruction of the equipment.

When cleaning the tow tractor, do not allow electrical equipment to be sprayed directly with liquid. Before cleaning, take the necessary protection measures.

If using compressed air, first remove stubborn dirt with a cold detergent. Before commencing lubrication, thoroughly clean oil filler openings and the areas around them. After cleaning, thoroughly dry the vehicle.

If you have taken comprehensive protective measures but water is still seeping in, blow the vehicle dry using compressed air to prevent rust and short-circuits.



NOTE

A vehicle that is cleaned frequently will also require more frequent greasing.

Accessing the electrical compartment



NOTE

Before doing any work

- *Push the emergency stop switch.*
- *Turn off the power switch.*
- *Disconnect the battery plug.*

Cleaning the battery and its compartment.

CAUTION

Risk of personal injury.

This operation must be carried out wearing protective gloves, goggles and clothing. Closely follow the safety precautions described in the relevant safety chapters.



ENVIRONMENT NOTE

Do not pour acidic cleaning water down the drain. For more information, refer to the battery usage instructions.

Battery in open compartment

- Check the battery frame for traces of sulphate.
- If there is only minimal sulphate build-up, just wipe the surface with a damp rag.
- If sulphate build-up is heavy, you will need to take out the battery, jet wash it and clean the frame.



NOTE

In the event of heavy sulphate build-up or excessive electrolyte spillage, contact an authorised dealer or service engineer immediately.

⚠ CAUTION

Risk of burns.

Brakes, motors, cables, and other electrical components may reach very high temperatures.

Open the electrical compartment cover

- Open the battery hood.

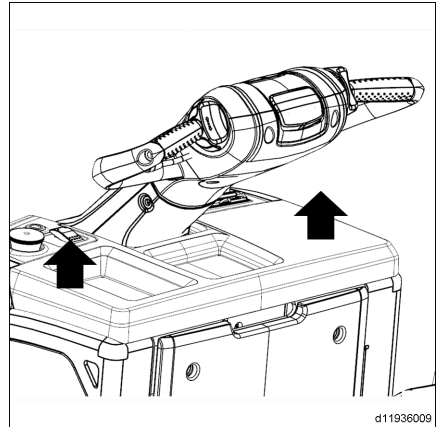

- Remove the fixing screws from the electrical compartment cover.

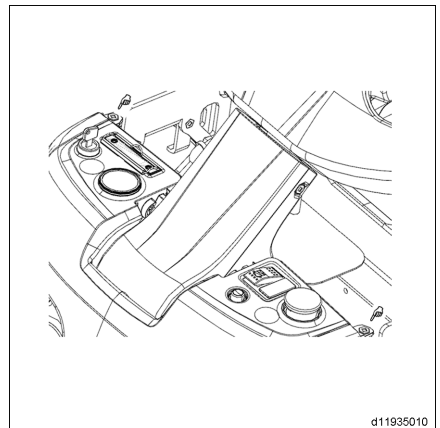
**i NOTE**

Follow the disassembly steps in reverse order to refit the electrical compartment cover.

Maintenance plan as required

Checking the auxiliary seat condition

This tow tractor is equipped with a simple auxiliary seat to support the driver's weight.

Inspect the following important points:

- Check the auxiliary seat height
- Is the height adjustment mechanism stable?
- Is the auxiliary seat cushion broken?

CAUTION

Risk of serious accident.

Do not drive the vehicle if the auxiliary seat is in poor condition.



NOTE

The driver should do these checks before operating the machine. If problems are found, maintenance must be performed by service engineers.

Steering tiller:check condition

the steering tiller is not just a control device, it also provides a support for the driver on the driver's platform.

Check the following important points:

- Tiller position is appropriate
- Tiller is securely fixed
- Tiller function is intact

CAUTION

Risk of serious accidents.

Do not drive the machine if the tiller is faulty.

Check fuses

- Remove the front cover of the tow tractor.

- Check for blown fuses.
- Change any blown fuses.

Fuse	Specification
1F1	125A
1F2	10A
1F3	10A
1F4	10A

i NOTE

We recommend that this work is carried out by a specialised service engineer.

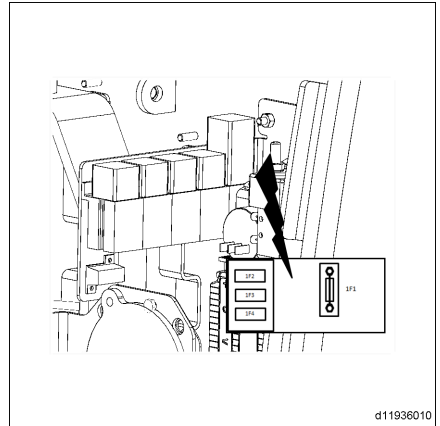

Inspection and maintenance overview

Inspection and maintenance overview

1000 hour service plan

At operating hours										Carried out	
1000										✓	✘
Preparations											
If necessary, clean the truck.											
Use diagnostic software to read the fault codes.											
Reset the service interval using the diagnostic software.											
Lubricate all pivots and lubricate on grease nipple.											
Traction motor											
Clean the motor housing.											
Wheels/brake system											
Check the wear on the tyre tread of the wheels.											
Check that the nuts are tightened.											
Check the parking brake clearance.											
Check the castor wheels clearance when stationary.											
Electrical equipment											
Disconnect power, clean circuit.											
Check the contacts and terminals of the contactors.											
Switch off the LAC controller and clean it.											
Check and clamp the connection cables and the connectors.											
Check and adjust the battery density and electrolyte level.											
Check the battery cables and connector.											
Check the adjustment of the rubber stops on the battery locking system.											
Check that the charger is working.											
Check whether the vehicle's lighting equipment, speakers, switches, etc. are working properly.											
Coupling and trailer											
Check whether the tow coupling is in working order.											
Check whether the trailer is properly connected.											
Final inspection											
Visually inspect the general condition of the undercarriage.											

At operating hours									Carried out	
1000									✓	*
Test drive the vehicle.										

10000 hour service plan

At operating hours									Carried out	
10000		20000		30000					✓	*
Preparations										
If necessary, clean the truck.										
Use diagnostic software to read the fault codes.										
Reset the service interval using the diagnostic software.										
Lubricate all pivots and lubricate on grease nipple.										
Traction motor										
Clean the motor housing.										
Transmission										
Change the reducer gear oil.										
Wheels/brake system										
Check the wear on the tyre tread of the wheels.										
Check that the nuts are tightened.										
Check the parking brake clearance.										
Check the castor wheels clearance when stationary.										
Electrical equipment										
Disconnect power, clean circuit.										
Check the contacts and terminals of the contactors.										
Switch off the LAC controller and clean it.										
Check and clamp the connection cables and the connectors.										
Check and adjust the battery density and electrolyte level.										
Check the battery cables and connector.										
Check the adjustment of the rubber stops on the battery locking system.										
Check that the charger is working.										
Check whether the vehicle's lighting equipment, speakers, switches, etc. are working properly.										

Inspection and maintenance overview

At operating hours								Carried out	
10000		20000		30000				✓	✘
Coupling and trailer									
Check whether the tow coupling is in working order.									
Check whether the trailer is properly connected.									
Final inspection									
Visually inspect the general condition of the undercarriage.									
Test drive the vehicle.									

Tractor motor

Traction motor: Cleaning the motor housing

- Unplug the battery connector.
- Open the electrical compartment.
- Clean the motor housing with compressed air.
- Check the electrical wiring and connectors for signs of overheating.
- Check that the connections are tight.

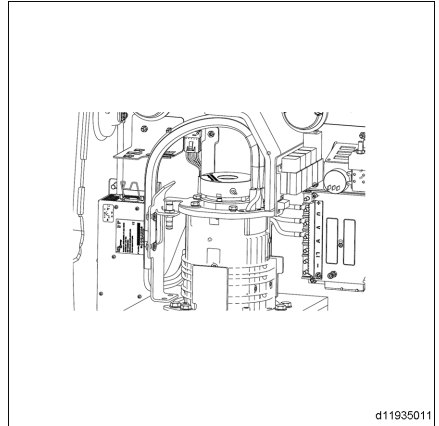

Gearbox

Gearbox

Servicing the reducer

Draining the oil



NOTE

This operation must be carried out by the service centre.

Steering/braking/wheels

Steering/wheels/brakes

Checking condition and tightness of wheels

- Use lifting equipment or a jack to raise the vehicle off the ground, then support the vehicle on suitable blocks. ▷
- Check that the wheels rotate freely and remove any coiled wires that may be obstructing them.
- Check the wear condition of the tyre treads.
- Replace wheels that are worn.
- Check the front wheels first, then the rear wheels.

⚠ CAUTION

Risk of equipment damage.

It is essential to remove any wire that may have wound round the wheel hubs and bearings.

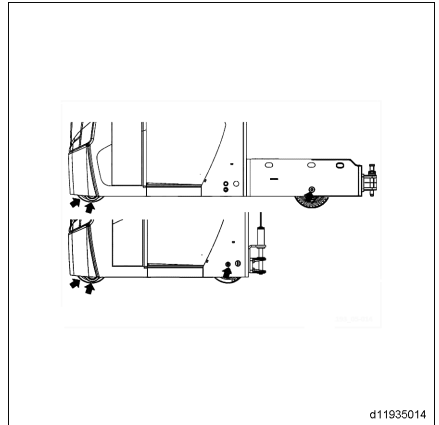

Checking that the wheels are tightened

- Use lifting equipment or a jack to raise the vehicle off the ground, then support the vehicle on suitable blocks. ▷
- Remove the front cover.
- Check the tightness of the nuts on the drive wheel, recommended torque setting: 80 N.m.
- Check the tightness of the castor wheels axle, torque setting: 20 N.m.
- Check the tightness of the rear wheel shaft, torque setting: 200 N.m. (for LTX10, LTX20)
- Check the tightness of the rear wheel shaft, torque setting: 250 N.m. (for LTX-T04)

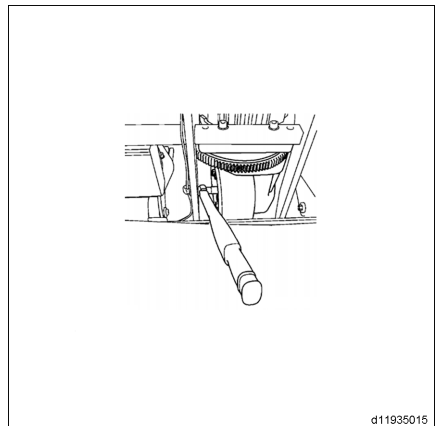

Steering/braking/wheels

⚠ CAUTION

Risk of serious injury and/or serious damage to the equipment.

These checks should be performed by an authorised service engineer. Wear protective gloves when replacing the traction wheel.

Adjusting the height of the castor wheels

- Use lifting equipment or a jack to raise the vehicle off the ground, then support the vehicle on suitable blocks.
- Adjust the height of the castor wheels according to the degree of drive wheel wear.
- Release the screw(2).
- Release the eccentric pin(1).
- Engage the pin(1) in the corresponding notch.

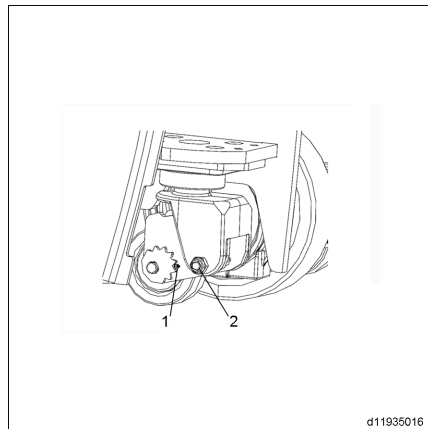

- Make sure the standard clearance is 8 mm. ▷
- Tighten the screw(2) again.

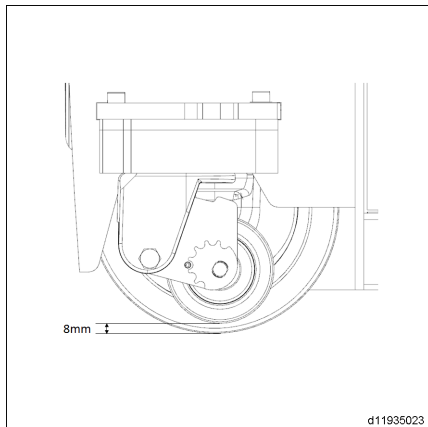

Steering/braking/wheels

Checking the brake air gap**IMPORTANT**

The mechanical braking torque is factory set.

- The brake must be checked in the braked position, i.e. with the power supply cut.
- Check the air gap on the brake using a set of wheel chocks.
- The value of the original air gap is 0.2 mm. After partial wear of the disc, the maximum air gap is 0.5 mm. Above this value, there is a risk of not being able to release the brake fully and a risk of overheating.
- If the air gap is close to the limit value of 0.5 mm, it must be adjusted.
- Loosen the three fixing screws (3).
- Adjust the three banjo bolts (4) to set the air gap to its original value of 0.20 mm.
- Retighten the three mounting screws (3).
- Check the air gap at 3 points at 120° intervals.
- Make sure that the air gap is equal right around the brake.

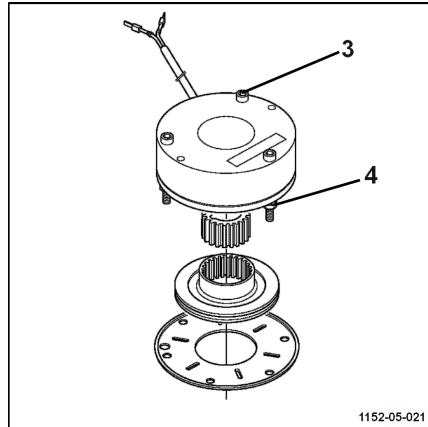
**NOTE**

We recommend that this operation be carried out by our After-Sales Service Centre.

Battery

Checking the on-board charger

- Connect the cord to the 220 V mains.
- Check that the green indicator light on the display is flashing and that the red one is off (charging in progress).
- Check that the truck is immobilised (traction is not permitted) as long as it is connected to the 220 V supply.
- Disconnect the mains cord.

Battery maintenance

The following steps relate to lead-acid batteries with electrolyte.

CAUTION

Risk of serious injury and/or serious damage to the equipment.

Avoid contact with the electrolyte. Avoid causing a short circuit. Refer to the recommendations in the daily checks section. Wear protective gloves and goggles when working on the battery. In case of contact with eyes or skin, rinse immediately with plenty of clean water, then seek medical advice if the situation is severe. Charging the battery releases hydrogen, which creates an explosive mixture when mixed with oxygen. Therefore do not create sparks, do not smoke and keep naked flames away from a battery which is being charged or has recently been charged. To avoid the accumulation of hydrogen, charge the battery in a well-ventilated place and keep the battery hood open whilst charging. Do not place metal objects on the battery: there is a risk of creating a short-circuit.

Measuring the electrolyte level and adding distilled water

- This check and any required top-up with distilled water should be carried out every week (after charging in the case of open lead-acid batteries).
- Turn off the power switch, open the battery hood, and unplug the battery connector.
- Check the electrolyte level.

- Add distilled water to top up cells with a low water level.
- Refit the plug.

CAUTION

Risk of damage to the equipment.

Only top up with demineralised water. Never top up before charging (risk of overflow).

NOTE

For more information, see the instructions provided with the battery.

Measuring the electrolyte density

Measuring the density gives an accurate indication of the charging status of each cell (only in an open lead-acid battery). This measurement can be taken before or after charging.

- The minimum density when the battery is 80% discharged is 1.14.
- The maximum density when the battery is 100% fully charged is 1.29 to 1.32. (Depends on the design)
- Note the values in your battery log book.
- Open each cell cover and check each one in turn as described above.
- After completing the measurement, refit the hood.

Battery



NOTE

Contact a service engineer if the density of the electrolyte in each battery pack is different, or the density of some battery packs is very low. Charging the battery when the density of the electrolyte is below 1.14 is very detrimental to its operating life.

Check the condition of the battery cables, terminals and connector

- Make sure that the cable insulation is not damaged and that the connector shows no signs of heating.

Removing/replacing the battery

NOTE



NOTE

When handling batteries, make sure that all lifting equipment used (crane, hoist, slings, hooks, vehicles, handling devices) is sufficient for the weight of the battery.



NOTE

If installing a spare battery, make sure that the specifications of the spare battery (weight, size, voltage, capacity, connector socket) match those of the original battery. Refer to the vehicle rating plate to find out the maximum and minimum weight capacities.

⚠ CAUTION

Batteries are heavy and easily damaged; handle them with care.

The wearing of gloves is recommended.

⚠ CAUTION

Beware of pinching your fingers when removing and fitting the battery.

Keep your fingers away from moving parts to avoid any risk of trapping.

- Check the condition of the connector contact and keying pins.
- Check the condition of the locking tab on the battery connector.

⚠ CAUTION

Risk of serious accidents.

If you discover that the cables, terminals and/or battery connector are defective, stop using the vehicle immediately and contact an authorised dealer or service engineer.

⚠ CAUTION

There is a risk of damaging the machine.

Before using the vehicle, make sure that the battery connector is securely connected and locked.

⚠ CAUTION

There is a risk of damaging the machine.

Before using the vehicle, make sure that the screws on battery fix device is secured.

Changing the battery using a hoist

- Switch off the truck and press the emergency switch.
- Open the battery hood.
- Unplug the battery connector.

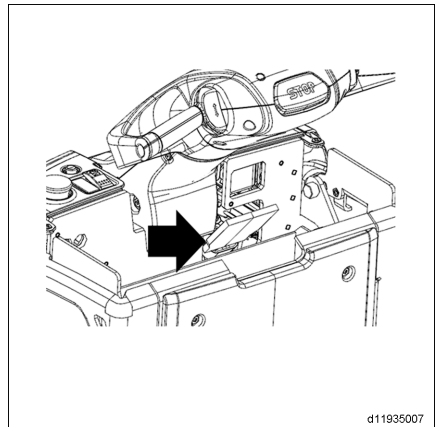

Battery

- Unscrew the screws(1) of the battery fix device on both sides. ▷

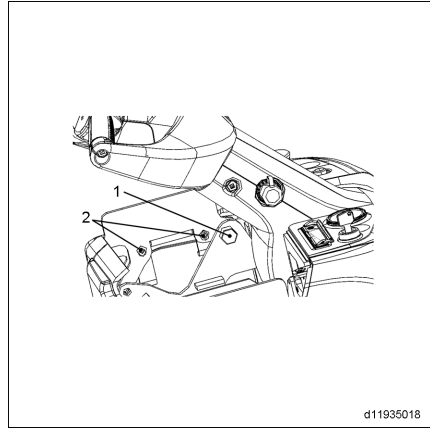

- Lift up the battery fix devices on both sides. ▷

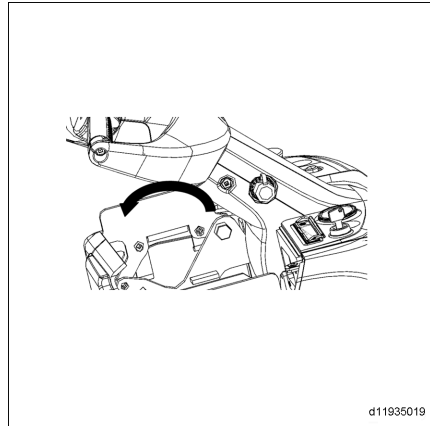

- Attach the hoist hook to the battery lifting eyes.
- Carefully controlling the hoist, position the battery in the specified location.
- To install the replacement battery, perform the above procedure in reverse order.

Side access battery: changing the battery using a moveable support

- Switch off the truck and press the emergency switch.
- Open the battery hood.

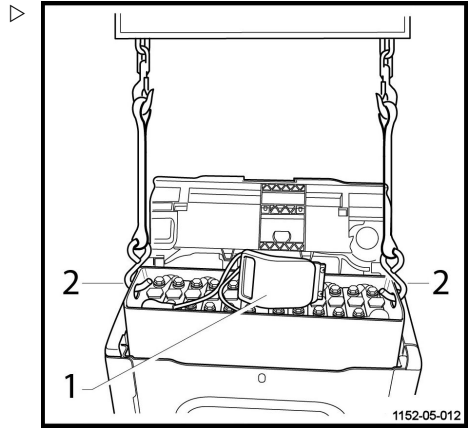

- Unplug the battery connector.

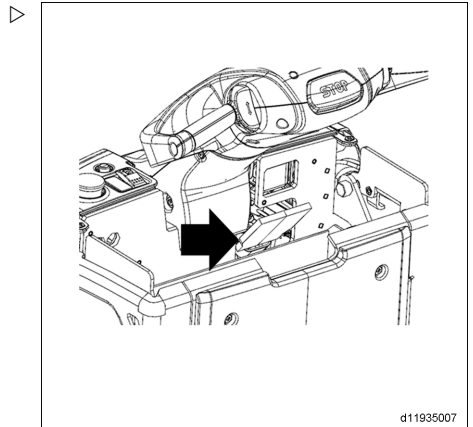

Battery

- Unscrew the screws(1) of the battery fix device on the battery removed side. ▷

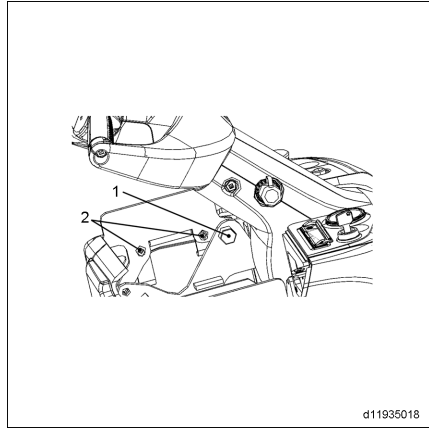

- Lift up the battery fix devices on the battery removed side. ▷

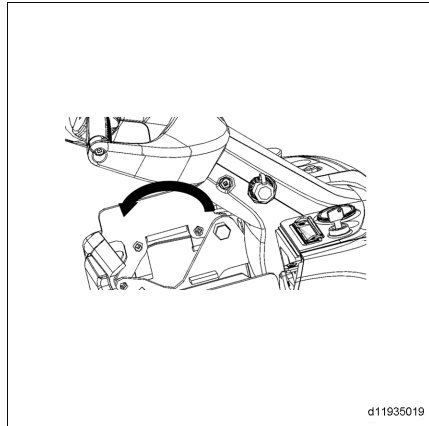

- Unscrew the screws(2) of the side panel.

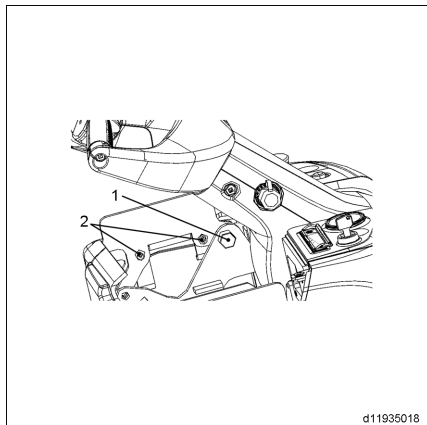

- The side panel is inserted on a slot. Remove the side panel.

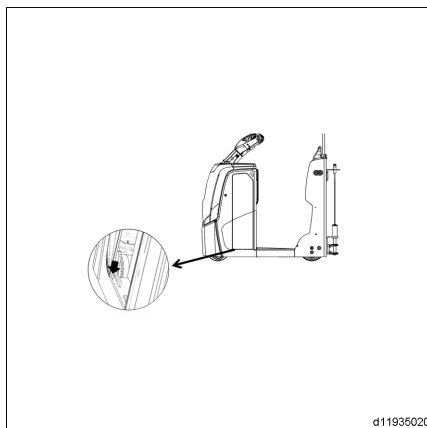

Battery

- Push the moveable support to the side, and keep the moveable support close to the truck. ▷



NOTE

Make sure that the wheel of the moveable support are locked when using the moveable support to replace the battery. Be sure that the moveable support is fixed when replacing the battery.

- Lock the wheels of the moveable support.
- Push the battery which is need to be replaced to the moveable support.
- Transport the battery to the charging station and transport the full charged battery to the side of the truck.
- To install the replacement battery, perform the above procedure in reverse order.

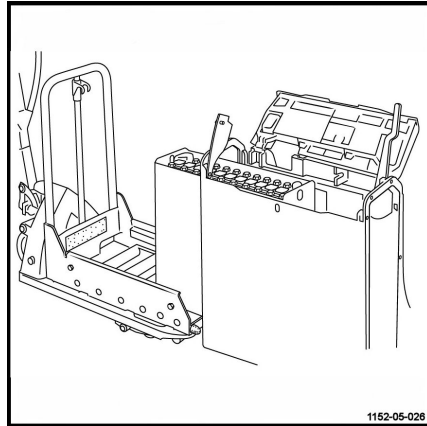

7

Technical data

Datasheet

Datasheet

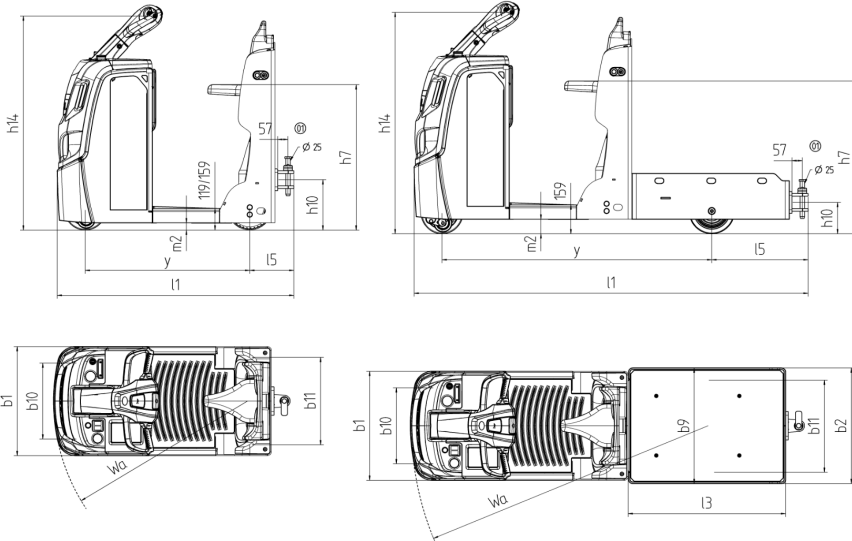

NOTE

01/2015 Version

Characteristics						
1.1	Manufacturer			Still	Still	Still
1.2	Model designation			LTX10	LTX20	LTX-T 04
1.3	Power unit			Battery	Battery	Battery
1.4	Operation			Stand-on	Stand-on	Stand-on
1.5	Load capacity	Q	kg	1000	2000	400/1000 ¹⁰⁾
1.6	Rated drawbar pull	F	N	190	400	300
1.7	Wheelbase	y	mm	907 ²⁾	907 ²⁾	1487 ²⁾

Weight						
2.1	Service weight		kg	620 ¹⁾	620 ¹⁾	755 ¹⁾
2.3	Axel load without load, front (drive)// rear (load)		kg	350 / 280	350 / 280	460 / 270

Wheels						
3.1	Tyres, front (drive)/rear (load) C=cushion rubber, P=polyurethane			C+PU/C	C+PU/C	C+PU/C
3.2	Tyre size, front (drive) wheel		mm	Ø230X75	Ø230X75	Ø230X75
3.3	Tyre size, rear (load) wheel		mm	2 X Ø250X80	2 X Ø250X80	2 X Ø250X80
3.4	Auxiliary wheels(dimensions)		mm	2 X Ø100X40	2 X Ø100X40	2 X Ø100X40
3.5	Wheels, number front (drive)/rear (load) (x=driven)			1x+2/2	1x+2/2	1x+2/2
3.6	Track width, front (drive)	b1 0	mm	414 ⁷⁾	414 ⁷⁾	414 ⁷⁾
3.7	Track width, rear (load)	b1 1	mm	480 ⁷⁾	480 ⁷⁾	505 ⁷⁾

Dimensions						
4.1	Height of backrest/seat (min/max)	h7	mm	800/985	800/985	800/985
4.2	Height of handle bar in operating position,min/max	h1 4	mm	1170/1270 ²⁾	1170/1270 ²⁾	1210/1310 ²⁾
4.3	Tow coupling height	h1 0	mm	276	276	165
4.4	Load platform height	h1 1	mm	NA	NA	289
4.5	Load platform length	l3	mm	NA	NA	868 ²⁾
4.6	Rear overhang	l5	mm	253 ⁹⁾	253 ⁹⁾	531 ⁹⁾
4.7	Load platform width	b9	mm	NA	NA	636 ²⁾
4.8	Overall length	l1	mm	1315 ²⁾	1315 ²⁾	2172 ²⁾
4.9	Overall width	b1/ b2		600 ²⁾	600 ²⁾	600/636 ²⁾

Datasheet

Dimensions						
4.1 0	Ground clearance, center of wheel-base	m ²	mm	40/80 ³	40/80 ³	80 ³
4.1 1	Turning radius	Wa	mm	1080 ⁴⁾	1080 ⁴⁾	1660 ⁴⁾

Performances						
5.1	Travel speed, with/without load		km/h	10/10 ⁶⁾	8/8 ⁶⁾	8/8 ⁶⁾
5.2	Drawbar pull (60 minutes rating)		N	190	400	300
5.3	Maximum drawbar pull (5 minutes rating)		N	1760	1760	1760
5.4	Climbing ability, with/without load, 30 minute rating		%	NA	NA	NA
5.5	Maximum climbing ability, with/without load, 5 minute rating		%	8% / 10% ⁵⁾	5% / 10% ⁵⁾	5% / 10% ⁵⁾
5.6	Service brake			Electromagnetic	Electromagnetic	Electromagnetic

Drive						
6.1	Drive motor, 60 minute rating		kW	1.5	1.5	1.5
6.3	Battery according to IEC			2 PZB	2 PZB	2 PZB
6.4	Battery voltage/rated capacity (5h)		V/A h	24/200	24/200	24/200
6.5	Battery weight (±5%)		kg	185 ⁶⁾	185 ⁶⁾	185 ⁶⁾
6.6	Energy consumption acc. to VDI cycle		kW h/h	1.102 (72 cycles ⁸⁾)	1.21 (62 cycles ⁸⁾)	1.35 (59 cycles ⁸⁾)

Others						
8.1	Type of drive control			LAC	LAC	LAC
8.2	Noise level at operator's ear		dB	75	75	75
8.3	Vibration to the operator, LTX10, LTX20 / LTX - T04		m/s ²	1.30/1.46	1.30/1.46	1.09/1.11

Figures for standard version may vary when options equipment is fitted

- 1) Including item 6.5 battery weight.
- 2) $\pm 5\text{mm}$
- 3) $\geq 95\%$
- 4) $\leq 105\%$
- 5) $\geq 100\%$
- 6) $\pm 5\%$
- 7) $\pm 4\text{mm}$
- 8) The number of laps around the standard testing track in one hour.
- 9) With single position hook.
- 10) Platform load capacity is 400 kg and hook load capacity is 1000 kg.

NUMBERS AND SYMBOLS

10000 hour service plan.	97
1000 hour service plan.	96

A

Accessing the electrical compartment.	92
Accessory bar (optional).	40
Address of manufacturer.	1
Adjusting the tiller angle.	60
Ascending a slope.	61
Attachments	
Special risks.	17

B

Battery	
Disposal.	9
Battery acid.	27
Battery maintenance.	105
Before driving.	48
Brake, horn and lighting.	63

C

Check fuses.	94
Checking the auxiliary seat condition.	94
Checking the battery charging status.	83
Checking the brake air gap.	104
Checking the brakes.	79
Checking the condition of cables, terminals and battery connector.	85
Checking the on-board charger.	105
Checking the travel direction control func- tion.	79
Checks before initial use.	51
Cleaning.	92
Cleaning the motor housing.	99
Commissioning.	48
COmmissioning.	54
Conformity marking.	3
Consumables.	26
Disposal.	28
Safety information for handling battery acid.	27
Safety information for handling oils. ...	26
Contact details.	1
Copyright and trademark rights.	6
Coupling.	64
Coupling the trailer.	65

Cross references.	7
------------------------	---

D

Daily checks before use.	52
Datasheet.	114
Date of edition of this manual.	6
Declaration of conformity.	4
Definition of directions.	8
Descending a slope.	62
Determining the drive direction.	56
Display unit.	41
Disposal	
Battery.	9
Components.	9
Disposal of old trucks.	72
Documentation scope.	5
Driver rights, duties and rules of behaviour. ...	20
Drivers.	20
Driving on a slope.	61
Driving position.	60
Driving the truck with cargo.	68

E

EC declaration of conformity in accordance with the Machinery Directive.	4
Electrical insulation test.	25
Electronic key (option).	44
EMC - Electromagnetic Compatibility	31
Emergency stop switch.	55
Emissions.	28

F

Forward/reverse travel.	56
Functional description.	8

G

General.	2
General view.	34

I

Identification plate.	37
Illustrations.	8
Insurance cover on company premises. ...	22

L

Labels.	36
--------------	----

M		
Measures to be carried out before storing a forklift truck.	71	
Measuring battery insulation resistance.	25	
Measuring the insulation resistance of the electrical system.	25	
Medical equipment.	23	
Modifications and refitting.	22	
Multi-purpose grease.	76	
O		
Oils.	26	
Opening the battery hood.	84	
Operating company.	20	
Operating devices 1193.	39	
Operating instructions.	53	
Ordering spare parts and wear parts.	75	
P		
Packaging.	9	
Place of use.	15	
Plugging in/unplugging the battery connector.	84	
Prohibition of use by unauthorised persons.	21	
Putting the tow tractor back into service.	71	
R		
Recommended lubricants.	76	
Removing/replacing the battery.	85, 106	
Residual dangers, residual risks.	16	
S		
Safety devices		
Misuse.	30	
Safety inspection.	24	
Signals.	7	
Specialist.	20	
Special risks.	17	
Stability.	16	
Stand-on/seated driving operation.	57	
Steering tiller:check condition.	94	
Steering unit.	57	
Steering, wheels, brakes.	101	
Stopping and starting on a slope.	62	
T		
Technical Description.	12	
Technical inspection and maintenance characteristics.	77	
Testing safety devices.	81	
Testing the steering unit.	81	
Transmission oil.	76	
Transporting the truck.	70	
U		
Unauthorised use.	14	
Update of this manual.	6	
W		
Warning regarding non-original parts.	22	
Working environment.	53	

