

## Original instructions

### iGo neo

Supplement to the standard operating  
instructions for the OPX

OPX 20  
OPX 25

OPX-L 12  
OPX-L 20  
OPX-L 20 S





## Address of manufacturer and contact details ▷

STILL GmbH  
Berzeliusstraße 10  
22113 Hamburg, Germany  
Tel. +49 (0) 40 7339-0  
Fax: +49 (0) 40 7339-1622  
Email: [info@still.de](mailto:info@still.de)  
Website: <http://www.still.de>



## Rules for the operating company of industrial trucks

In addition to these operating instructions, a code of practice containing additional information for the operating companies of industrial trucks is also available.

This guide provides information for handling industrial trucks:

- Support for the creation of the statutory hazard assessment
- Information on how to select suitable industrial trucks for a particular area of application
- Prerequisites for the safe operation of industrial trucks
- Information on the use of industrial trucks
- Information on transport, initial commissioning and storage of industrial trucks

### Internet address and QR code



The information can be accessed at any time by pasting the address <https://m.still.de/vdma> in a web browser or by scanning the QR code.



## 1 Foreword

<b>Your iGo neo</b> .....	2
Intelligent order picking - your iGo neo .....	2
Conformity marking .....	3
EC declaration of conformity in accordance with the Machinery Directive .....	4
<b>Using the iGo neo</b> .....	5
Intended use .....	5
Improper use .....	6
Requirements for the place of use .....	6
Cold store application (variant) .....	7
Requirements for load carriers and loads .....	8
Chassis extension for wide load carriers (variant) .....	10
Required safety distances in the aisle .....	11
Customer-specific configuration by the authorised service centre .....	12
Copyright clause for open-source programs .....	13
Declaration of conformity in accordance with the Radio Equipment Directive 2014/53/EU .....	13
<b>Roadways</b> .....	14
Requirements for the ground conditions of roadways .....	14
Suitable roadways .....	14
<b>Information about the documentation</b> .....	16
Validity of this supplement to the operating instructions .....	16
Issue date and topicality of the operating instructions .....	16
Copyright and trademark rights .....	17
Explanation of information symbols used .....	17
The term "rack" in these operating instructions .....	17
<b>Environmental considerations</b> .....	19
Disposing of components used for "Assistance" mode .....	19

## 2 Safety

<b>Definition of terms used for responsible persons</b> .....	22
Duties of the operating company .....	22
Duties of the operator .....	23
Additional requirements applicable to the authorised service centre .....	24
Specialist .....	25
<b>Basic principles for safe operation</b> .....	26
Modifications and retrofitting .....	26
Warning regarding non-genuine parts .....	27

Damage, defects and misuse of safety systems . . . . .	28
Medical equipment . . . . .	29
<b>Residual risk</b> . . . . .	30
Residual dangers, residual risks . . . . .	30
Overview of hazards and countermeasures . . . . .	31
Danger to employees when "Assistance" mode is used . . . . .	33
<b>Safety tests</b> . . . . .	35
Regular safety inspection of the truck . . . . .	35
<b>Emissions</b> . . . . .	35
<b>Labelling points</b> . . . . .	36
<b>3 Components of the iGo neo</b>	
<b>Overview of components used for "Assistance" mode</b> . . . . .	38
<b>LED signalling units</b> . . . . .	39
Information signals and warning signals on the LED signalling units . . . . .	39
Truck alignment display on the LED signalling units . . . . .	40
<b>Operator detection</b> . . . . .	41
Operator detection system . . . . .	41
Movement tracking sensors . . . . .	42
Position tracking of the remote control . . . . .	43
<b>Laser scanner</b> . . . . .	44
Function of the safety laser scanner . . . . .	44
<b>Foot protection sensors</b> . . . . .	46
Function of the foot protection sensors (OPX-L 20 S) . . . . .	46
<b>Keypad on the side of the truck</b> . . . . .	47
Functions of the keypad on the side of the truck . . . . .	47
<b>iGo neo buttons</b> . . . . .	48
Functions of the iGo neo buttons . . . . .	48
<b>Emergency off switch</b> . . . . .	49
Additional emergency off switches . . . . .	49
<b>Remote control</b> . . . . .	50
Functions of the remote control . . . . .	50
Remote control buttons . . . . .	51
Charging the remote control . . . . .	52
Changing the remote control . . . . .	54

<b>4</b>	<b>Operating the iGo neo</b>	
	<b>Checks and tasks to be carried out when commencing "Assistance" mode</b> . . . . .	56
	Safety information for carrying out the tests . . . . .	56
	Visual inspections before switching on "Assistance" mode . . . . .	56
	Checks after switching on "Assistance" mode . . . . .	57
	<b>Safety regulations in "Assistance" mode</b> . . . . .	61
	Instructions for the safe operation of the iGo neo . . . . .	61
	Priority rules in mixed "Manual/Assistance" traffic . . . . .	68
	<b>Collision avoidance of the iGo neo</b> . . . . .	69
	Limits to the detection of obstacles . . . . .	69
	Keeping roadways clear of obstacles . . . . .	73
	Collision avoidance in "Assistance" mode . . . . .	75
	"Easy Protect" collision avoidance (variant) . . . . .	77
	<b>Operating the truck in "Assistance" mode</b> . . . . .	83
	Overview of "Assistance" mode . . . . .	83
	Switching the truck on and off . . . . .	85
	Switching on "Assistance" mode . . . . .	86
	Adjusting the truck alignment . . . . .	88
	Positioning the truck correctly in the aisle . . . . .	89
	Switching between ACTIVE and PAUSED states for "Assistance" mode . . . . .	91
	Identifying the operator . . . . .	93
	Stopping automatically at the end of the racking or in a crosswise roadway . . . . .	94
	Truck behaviour in the event of an emergency stop . . . . .	96
	Moving the stop position next to the operator to the next pallet . . . . .	98
	Driving automatically without movement tracking . . . . .	100
	Lifting and lowering the fork carriage . . . . .	101
	"Z picking" mode . . . . .	103
	Setting the drive programme when operating in "Assistance" mode . . . . .	104
	Warning sounds in "Assistance" mode . . . . .	105
<b>5</b>	<b>Storage</b>	
	<b>Storing and shutting down the iGo neo</b> . . . . .	108
<b>6</b>	<b>Cleaning</b>	
	<b>Cleaning the components used for "Assistance" mode</b> . . . . .	110
<b>7</b>	<b>Transport</b>	
	<b>Transporting the truck</b> . . . . .	114

## 8 Maintenance

Maintaining the iGo neo .....	118
Maintenance - 1000 hours / yearly .....	120

## 9 Technical data

DimensionsiGo neo OPX 20, 25 .....	124
DimensionsiGo neo OPX-L 12 .....	125
DimensionsiGo neo OPX-L 20 .....	126
DimensionsiGo neo OPX-L 20 S .....	127
VDI datasheetiGo neo OPX 20, 25 .....	128
VDI datasheetiGo neo OPX-L 12, 20, 20 S .....	134



1

---

## Foreword

Your iGo neo

## Your iGo neo

### Intelligent order picking - your iGo neo



The iGo neo works with its operator as an autonomous team-mate. It accompanies the operator at every stage of the order-picking process and is always within reach. It intuitively adapts to the working rhythm of its human companion.

This autonomous team function is made possible by the motion tracking system developed by STILL. Two high-performance sensors with a 360° circumferential view monitor the entire surrounding area. The intelligent software tracks all of the operator's movements, making the iGo neo the first order picker with cognitive skills.

#### Measurable increase in efficiency

The iGo neo is based on the concept of "Automation on Demand". The operator can opt to operate the truck manually or autonomously at any time, depending on the situation. Unlike conventional automation solutions, no complex setup is required for operation.

Once it is moved to the start position at the starting point, the highly adaptive iGo neo is

ready for operation right away. The truck uses sensors to navigate at a selected distance from the racks. It intelligently adapts to the traffic situation, taking the local conditions into account and slotting seamlessly into the current material flow. The iGo neo respects junctions, obstacles and the flowing traffic of autonomous and conventional trucks. This means that autonomous and conventional trucks can drive in convoy safely for the first time.

The operator can move freely around the truck during loading and unloading. It is irrelevant whether the operator is picking orders on the right, on the left or on both sides. Time that would normally be spent climbing in and out is saved. Walking along unnecessary routes is a thing of the past. The fast, faultless picking system moves straight to the central position.

The result is a measurable increase in process safety and efficiency.

#### Safety first

The iGo neo uses intelligent navigation and reliable safety monitoring to maintain a safe

distance from obstacles. The surrounding area and people in the vicinity are completely protected.

The iGo neo autonomously detects the entire warehouse layout using its laser environment recognition system. As well as racks and obstacles, the system identifies its operator and all other people in the area.

The safety laser scanner on the front guarantees driving safety through early identification and intelligent assessment of obstacles. The truck's own robotic computer converts the scanner data to a steady driving style that can be adjusted at any time. Damage to the load during full braking is effectively avoided.

### Less is more

The iGo neo also breaks new ground when it comes to communicating with the operator.

The innovative concept of the iGo eliminates the need for complex, cluttered operating status displays. Simple light codes and symbols convey everything that the operator needs to know during operation. The light codes are displayed via an innovative LED signal strip. The non-verbal interface to the operator means that the iGo neo overcomes linguistic, cultural and age-related limitations.

### First in intralogistics

The STILL iGo neo creates an intuitive partnership between the truck and its operator, paving the way for a safe and efficient future in intralogistics.

## Conformity marking

The manufacturer uses the conformity marking to document the conformity of the industrial truck with the relevant directives at the time of placing on the market:

- CE: in the European Union (EU)
- UKCA: in the United Kingdom (UK)
- EAC: in the Eurasian Economic Union

The conformity marking is applied to the nameplate. A declaration of conformity is issued for the EU and UK markets.

An unauthorised structural change or addition to the industrial truck can compromise safety, thus invalidating the declaration of conformity.



conformity symbols

Your iGo neo

## **EC declaration of conformity in accordance with the Machinery Directive**

The EC declaration of conformity in accordance with the Machinery Directive provided in the original operating instructions for the series-production truck is valid for the iGo neo.

## Using the iGo neo

### Intended use

The iGo neo is based on a manually operated STILL series-production truck that is equipped with additional navigation and safety components.

The truck can be used in two different modes of operation: **Manual mode** and **Assistance mode**.

**Manual mode** corresponds to normal operation of the series-production truck:

- Manual operation in ride on mode

**Assistance mode** is the additional mode of operation of the iGo neo:

- The truck detects the position of the operator and the contour of the warehouse aisle. During order picking, the truck independently follows the operator along this contour. This enables the operator to load and unload the truck without interruption. The truck maintains safety distances from single pallet positions and obstacles
- The operator can also control truck functions **Assistance mode** using a remote control

The truck must only be used for its intended purpose as described in these operating instructions. In addition, the provisions in the original operating instructions for the series-production truck apply.

If the truck is to be used for purposes other than those described in the operating instructions, the approval of the manufacturer and, if applicable, the relevant regulatory authorities must be obtained in advance to prevent hazards.

The truck is only to be used for company-internal transport in the **Manual** and **Assistance** modes of operation. Use of the truck is restricted to the commercial and industrial sector.

Regardless of the safety devices present in the system, the operator remains responsible for the safe operation of the truck at all times, even in **Assistance mode**.

## Using the iGo neo

### Improper use

The operating company or operator, and not the manufacturer, is liable for any hazards caused by improper use.

It is prohibited to use the truck for purposes other than those described in these operating instructions.

The truck is not permitted to be used:

- On or along public roads
- In areas at risk of explosion
- For transporting dangerous goods
- For transporting people or animals as a load

### Requirements for the place of use

The requirements for the place of use of the truck correspond to the requirements that are described in the original operating instructions for the series-production truck.

In addition, the following restrictions apply:

- The truck is **not** suitable for cleanroom environments
- The truck must only be used indoors in weather-protected locations
- Special controls apply for use in cold stores and in cold climates below +5°C (see the chapter entitled "Cold store application")

Permissible working environment for the truck:

Permitted temperatures		
Usage	Min. °C	Max. °C
Operation	0	40
Storage	5	45

Permitted air humidity		
Usage	Min. %	Max. % (without condensation water)
Operation	5	95
Storage	5	95

## Alternating operation between different temperature ranges

### CAUTION

Danger from the optical safety systems fogging up when moving between warm areas and cold areas

When the truck is in *Assistance* mode, ensure that the optics covers (inspection windows) on the movement tracking sensors, on the foot protection sensors and on the safety laser scanner do not fog up.

If the optics cover of the safety laser scanner fogs up, the truck may respond by initiating an emergency stop.

- Clean any fogged-up optics covers before starting operation in *Assistance* mode (see the chapter entitled "Cleaning").

The truck is not affected by this issue when in *Manual* mode.

---

## Cold store application (variant)

The truck must be fitted with special cold store equipment for operation at temperatures below +5°C.

If cold store equipment is fitted, the truck may also be operated within the temperature range between 0°C and +5°C.

### CAUTION

The truck must not be switched off or parked in the cold store area.

- Always drive out of the cold store area before parking and switching off the truck.
- 

### CAUTION

Danger from condensation water after driving out of the cold store area

After driving out of the cold store area, leave the truck to stand for at least 30 minutes until any condensation water has evaporated.

- Never drive the truck into the cold store area if it has condensation water on it.
  - Avoid the formation of ice on the truck.
-

## Using the iGo neo

### ⚠ CAUTION

Danger from the optical safety systems fogging up when moving between warm areas and cold areas

During use, ensure that the optics covers (inspection windows) on the movement tracking sensors, on the foot protection sensors and on the safety laser scanner do not fog up.

If the optics cover of the safety laser scanner fogs up, the truck may respond by initiating an emergency stop.

- Clean any fogged-up optics covers before starting operation in Assistance mode (see the chapter entitled "Cleaning").

## Requirements for load carriers and loads

Load carriers (pallets, crates, trolleys) that are wider than the truck (max. 80 cm) must not be transported in Assistance mode.



### NOTE

*As an option, trucks can be equipped or retro-fitted for load carriers with a width of up to 100 cm. See the chapter entitled "Chassis extension for wide pallets (variant)".*

The weight and type of load must conform to the specifications in the original operating instructions for the series-production truck.

The load carrier must not exceed the truck contour at the side (1). The load must not protrude beyond the load carrier in a longitudinal or lateral direction (2).

The stability of the truck must not be jeopardised by the weight and height of the load, including when cornering.

The load must be secured so that it cannot fall from the truck or slip and protrude beyond the lateral truck contour, including when cornering. The load must be stacked carefully, with the centre of gravity as low as possible.

Load carriers and loads that do not meet these specifications may be moved in Assistance mode only if the truck safety devices are adjusted in advance by the

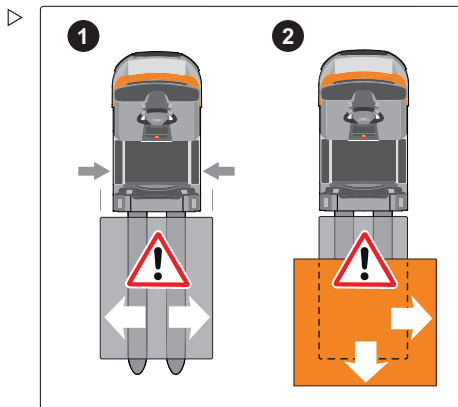



manufacturer. Adjustments of this type must be performed only by qualified personnel at the manufacturer who have been trained to complete this work.

## Using the iGo neo

## Chassis extension for wide load carriers (variant) ▷

Only load carriers that are no wider than the truck may be transported in *Assistance* mode. The chassis extensions (1) increase the truck width from 80 cm to 100 cm.

Trucks with a chassis extension (2) may transport load carriers up to a maximum width of 100 cm in *Assistance* mode.

Trucks without a chassis extension (3) may not transport load carriers wider than 80 cm.

The protective fields of the safety laser scanner are adapted for trucks with the "chassis extension for wide load carriers" variant.

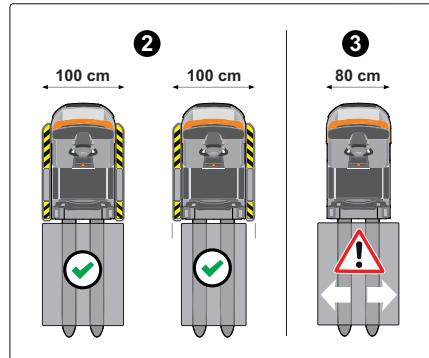
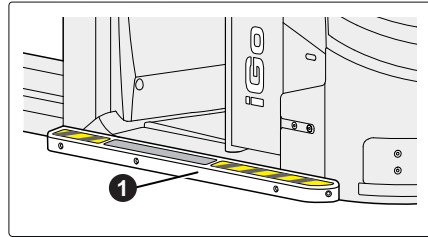

### ⚠ WARNING

Risk of injury to the feet from load carriers that are wider than the truck

When setting off in *Assistance* mode, the feet of the operator can be crushed by extra-wide load carriers.

## Required safety distances in the aisle ▷

Before using the iGo neo, the operating company must ensure that nobody could be put at risk as a result of operating the truck in *Assistance* mode. The aisle widths must allow for the required safety distance between the truck and the racks or any obstacles on the roadway.

The shaded area shows the minimum safety distances ( $X_1$ ,  $Y_1$ ,  $Z_1$ ) that the iGo neo must maintain. The authorised service centre can set increased safety distances ( $X_2$ ,  $Y_2$ ,  $Z_2$ ) according to the requirements for use.

The iGo neo maintains the following safety distances from objects in the aisle during operation in *Assistance* mode:

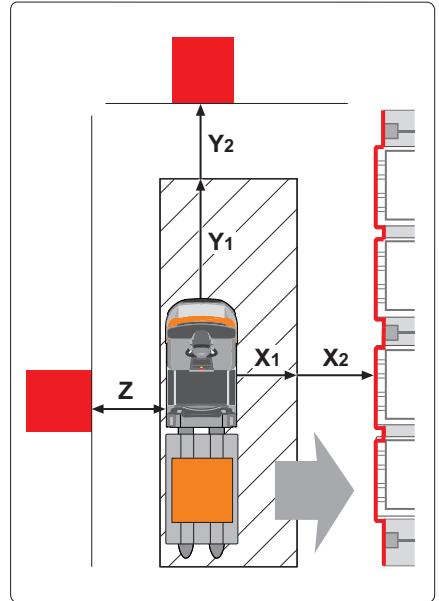

Example: Truck alignment RIGHT

Safety distances (example: "truck alignment RIGHT")		
Distance from the rack contour and obstacles on the right	$X_1$	50 cm (minimum distance)
	$X_2$	Adjustable
Distance from obstacles (front)	$Y_1$	50 cm (minimum distance)
	$Y_2$	Adjustable
Distance from the rack contour and obstacles on the left	$Z$	5 cm * (minimum distance)

The truck always maintains a distance ( $X_1$ ) of at least 50 cm from the rack contour on the side of the roadway to which the truck is aligned. This corridor is intended to ensure the safety of persons in the working environment. For safety reasons, it is recommended that a minimum distance of 50 cm is set for **both** sides of the truck ( $X_1$ ,  $Z_1$ ).

If a lateral distance ( $Z$ ) of less than 50 cm is set on the opposite side of the roadway to which the truck is aligned, suitable protective measures may be required.

## Using the iGo neo

Suitable protective measures may include:

- Floor markings
- Warning signs

## Customer-specific configuration by the authorised service centre

The authorised service centre can configure Assistance mode to suit the specific application conditions. Amongst other things, the following parameters can be set:

- Collision avoidance "Easy Protect"
- "Alternating order picking" mode (support when frequently changing sides within the aisle)
- Dynamic and maximum speed of the drive programmes
- Start/stop positions when transporting several pallets in succession
- Duration of the run-on time (robotics system) after the truck has been switched off
- Minimum distance to the rack in Assistance mode
- Minimum width of a crosswise roadway (crosswise roadway detection)
- Minimum lateral distance to any obstacles in the roadway
- Minimum distance to trucks ahead, with overhang
- Preferred truck alignment
- Adaptation to the fork length of the truck

## Copyright clause for open-source programs

STILL uses open source software to operate the iGo neo as licensed by the owners of the respective rights. The used open source software can be made available for general use, however **excluding any liability**. This exclusion of liability includes implicit warranty of marketability or suitability of the software for a particular use. For more details, please refer to the individual license documents.

On request, the license text can be made available in print.

For further information please contact us:

DE: [www.still.de/igo-opx-lizenz](http://www.still.de/igo-opx-lizenz)

EN: [www.still.de/igo-opx-licence](http://www.still.de/igo-opx-licence)

## Declaration of conformity in accordance with the Radio Equipment Directive 2014/53/EU

The manufacturers of the radio equipment installed in the industrial truck declare that the radio equipment corresponds to the Radio Equipment Directive 2014/53/EU. The declarations of conformity can be viewed at the following Internet address:

<https://www.still.de/eu-declarations.html>

## Roadways

# Roadways

## Requirements for the ground conditions of roadways

The truck is equipped with running wheels and drive wheels made from Vulkollan. The ground conditions of roadways affect the length of the braking distance (e.g. when performing an emergency stop) and therefore also have implications for the safety of persons and equipment.

The roadways on which the iGo neo will be used must be sufficiently flat, provide sufficient grip (good roughness properties) and offer sufficient load-bearing capacity. The requirements for the ground conditions are defined in the operating instructions of the series-production truck.

- Contact your authorised service centre if you are unsure about the correct conditions for the ground.

## Suitable roadways

In *Assistance* mode, the truck must only be used on suitable roadways.

The requirements for roadways described in the original operating instructions of the series-production truck also apply to trucks with the additional *Assistance* mode of operation.

In addition, the following provisions apply:

## Additional requirements for roadways suitable for the "Assistance" mode of operation

### DANGER

#### Risk of accident due to dirty roadways

Roadways must always be kept clean. Contamination resulting from moisture, oils, greases, dust, chips etc. can cause faults and reduce safety.

- Always keep roadways clean.
- For roadways, do not use any cleaning materials or care products that smooth the surface.

**⚠ DANGER****Risk of accident from sloping edges and gradients on or in the roadway**

In *Assistance* mode, the truck does not check the roadway for height differences, e.g. on sloping edges, steps, platforms, ramps and gradients. The truck will tip or fall over.

- Maintain a safe distance away from height differences on or in the roadway when the truck is in *Assistance* mode.
  - Always use *Manual* mode to drive along difficult roadways.
- 

The roadways must meet the requirements as per EN 1525 A.9.

Roadways must be free of impairments, such as holes, troughs or damage to the surface of the roadway.

The truck must not drive up and down longer gradients when in *Assistance* mode. The truck must always be in *Manual* mode when driving along these kinds of roadways.

## Information about the documentation

# Information about the documentation

## Validity of this supplement to the operating instructions

This supplement to the operating instructions applies in addition to the existing operating instructions for the series-production truck and both are to be considered as the original operating instructions. The operational and safety information in the standard operating instructions continues to be valid in its entirety unless it is specifically countermanded in this supplement to the operating instructions.

### DANGER

#### **Risk of accident!**

It is essential that information in this supplement to the operating instructions that differs to the information in the operating instructions for the series-production truck is observed!

---

## Storing the operating instructions

This supplement to the operating instructions must be kept with the operating instructions for the series-production truck so that operators and the operating company can access these instructions at any time. If the operating instructions are lost, the operating company must obtain a replacement from the manufacturer immediately. The operating instructions are included in the spare parts list and can be reordered as a spare part.

Sufficient quantities of the documentation must also be made available for staff training purposes.

## Issue date and topicality of the operating instructions

The issue date of these operating instructions can be found on the title page.

STILL is continuously working to enhance and improve the trucks. These instructions are subject to change, and any claims based on the information and/or illustrations contained



in these operating instructions cannot be asserted.

If you require technical support for the truck, please contact the authorised service centre.

## Copyright and trademark rights

These instructions must not be reproduced, translated or made accessible to third parties—including as excerpts—except with the express written approval of the manufacturer.

## Explanation of information symbols used

### DANGER

Indicates procedures that must be strictly adhered to in order to prevent the risk of fatalities.

### WARNING

Indicates procedures that must be strictly adhered to in order to prevent the risk of injuries.

### CAUTION

Indicates procedures that must be strictly adhered to in order to prevent material damage and/or destruction.

### NOTE

*For technical requirements that require special attention.*

### ENVIRONMENT NOTE

*To prevent environmental damage.*

## The term "rack" in these operating instructions

In Assistance mode, the iGo neo automatically navigates around the outer contour of an aisle. The terms rack and aisle are used in this

## Information about the documentation

context to refer to this general idea. These operating instructions also apply to storage area situations in which the truck drives along a contour formed by other load carriers (e.g. pallets in block storage areas).

## Environmental considerations

### Disposing of components used for "Assistance" mode

The instructions for environmentally friendly disposal of truck components that are specified in the operating instructions for the series-production truck also apply to components used for Assistance mode.

Environmental considerations

2

---

**Safety**

## Definition of terms used for responsible persons

# Definition of terms used for responsible persons

## Duties of the operating company

The operating company is the natural or legal person or group who uses the truck or on whose authority the truck is used.

The operating company must ensure that the truck is only used for its intended purpose and in compliance with the safety regulations in these operating instructions and the operating instructions for the series-production truck.

The operating company must ensure that all users read and understand the safety information in these operating instructions and in the operating instructions for the series-production truck. Both sets of operating instructions must be accessible to the truck operator at all times.

The operating company is responsible for scheduling and correctly performing regular safety inspections, including safety inspections on the components used for Assistance mode.

The requirements for the operating company—as well as the rights, duties and rules of behaviour of the operating company—as described in the operating instructions of the series-production truck, also apply to trucks with the additional Assistance mode of operation.

In addition, the following provisions apply:

- As part of safety training, the operating company must instruct the operator on how to handle the truck in Assistance mode. This information applies in particular for the different methods of handling the truck in the Manual and Assistance modes of operation
- The operating company must instruct all affected personnel in the safe handling of a truck in Assistance mode
- The operating company is responsible for ensuring the safe condition of roadways and ground conditions (refer to the chapter entitled "Roadways")
- The operating company must ensure that the truck is only operated by persons who have been trained in the handling of Assistance mode

- The operating company must ensure that the set maximum speed of the truck is permissible in the work area and appropriate in terms of occupational safety
- The operating company must ensure that the work area of the truck is sufficiently lit. If the work area is insufficiently lit, working spotlights must be installed on the truck and switched on so that the operator always has sufficient visibility
- It is the responsibility of the operating company to implement and announce a right-of-way rule in favour of the iGo neo

The operating company must observe the national regulations, laws and accident prevention regulations.

## Duties of the operator

The operator is the person who drives the truck in **Manual mode** or **Assistance mode**.

The requirements for the operator—as well as the rights, duties and rules of behaviour of the operator—as described in the operating instructions of the series-production truck, also apply to the operators of trucks with the additional **Assistance** mode of operation.

As a minimum, the operator must comply with the following requirements:

- Minimum age: 18 years
- A valid driving license for the truck class
- Written authorisation from the operating company

As part of safety training, the operator must receive instruction from the operating company on how to handle the series-production truck and the iGo neo.

In addition, the following provisions apply:

### Special responsibility of the operator for the remote control

The operator must never leave the remote control unattended when performing their work and must never give the remote control to anyone else. The remote control may only be operated by the operator.

## Definition of terms used for responsible persons

When the truck is switched on, the remote control must be kept in a safe place to prevent unintentional operation. The remote control can be operated unintentionally, e.g. if it is carried in a trouser pocket / jacket pocket, or if objects are placed on top of the remote control. While operating the truck, the remote control must always be kept in the supplied holder.

Once work has been completed, the operator must ensure that the remote control cannot be accessed by unauthorised persons.

## Additional requirements applicable to the authorised service centre

Any work on components used for Assistance mode must only be performed by the service centre authorised by the manufacturer.

The service engineer must have received special training from the manufacturer regarding the handling processes, technology and repair work involved with the iGo neo. It is not permitted for other persons to perform work on the components used for Assistance mode. This instruction does not apply to cleaning procedures on components that are not located inside the truck; refer to the chapter entitled "Cleaning".

The following components are used for Assistance mode:

- Safety laser scanners
- Movement tracking sensors
- Control components
- Control electronics and control software
- Emergency off switch
- LED signalling unit
- Switches
- Remote control (including reception components)
- Collision camera (variant)
- Foot protection sensors (variant)



## Specialist

A qualified person is defined as a service engineer or a person who fulfils the following requirements:

- A completed vocational qualification that demonstrably proves their professional expertise. This proof should consist of a vocational qualification or a similar document.
- Professional experience indicating that the qualified person has gained practical experience of industrial trucks over a proven period during their career. During this time, this person has become familiar with a wide range of symptoms that require checks to be carried out, such as based on the results of a hazard assessment or a daily inspection.
- Recent professional involvement in the field of the industrial truck test in question and an appropriate further qualification are essential. The qualified person must have experience of carrying out the test in question or of carrying out similar tests. Moreover, this person must be aware of the latest technological developments regarding the industrial truck to be tested and the risk being assessed.

## Basic principles for safe operation

# Basic principles for safe operation

## Modifications and retrofitting

### CAUTION

Modifications without the required approval of the manufacturer or the competent authorities will invalidate the manufacturer's CE/UKCA declaration of conformity.

If retrofitting is carried out for work that is not listed in these operating instructions or in the operating instructions for the series-production truck, approval from the manufacturer must be obtained in advance. Any modifications to the construction can impair safety in Assistance mode and cause accidents.

### Modifications to components used for "Assistance" mode

Modifications to components used for Assistance mode may be carried out only with the specific approval of the manufacturer. Approval from the relevant authority must be obtained where applicable.

In particular, the following are not permitted:

- Modifications to components used for Assistance mode (safety laser scanner, movement tracking sensors, control components, control electronics and control software, emergency off switches, LED signalling unit, switches, 3D front view camera (variant), foot protection sensors (variant), remote control / reception components).

### Use of attachment parts

Attachment parts may be fitted only with the approval of the manufacturer as attachment parts can impair the safety functions of the truck. Approved attachment parts must not protrude beyond the contour of the truck or interfere with the field of vision of the laser scanners.

In particular, the following are not permitted:

- Additional, unauthorised attachment parts (e.g. headlights, terminal/monitor support mountings, additional shelves)
- No additional bores may be made on the safety components and the truck chassis.

### Modifications to the fork and truck geometry

In particular, the following are not permitted:

- Use of fork extensions
- Modifications to the fork spacing
- Modifications to the truck geometry (e.g. length, width, height of the truck, super-structures, additional surfaces and weights, chassis extensions).

### Modifying the truck parameters

#### **⚠ DANGER**

#### **Risk of accident as a result of all safety functions being lost**

Modifications by unauthorised persons to the parameters used by safety devices are forbidden.

Modifications to the truck parameters or component parameters may be performed exclusively by qualified personnel at the manufacturer who have been trained to complete this work! All modifications must be documented.

### Warning regarding non-genuine parts

Genuine parts, components and accessories, including for Assistance mode, are specially designed for this truck. We specifically draw your attention to the fact that parts, components and accessories supplied by other companies have not been tested and approved by STILL.

## Basic principles for safe operation

### **⚠ CAUTION**

Installation and/or use of such products may therefore have a negative impact on the design features of the truck and thereby impair active and/or passive driving safety in certain circumstances.

Only the authorised service centre may perform work on the components used for Assistance mode. The manufacturer accepts no liability for any damage caused by the use of non-genuine parts and accessories without approval.

## Damage, defects and misuse of safety systems

The operator must report any damage or other defects in components used for Assistance mode to the supervisory personnel immediately. The truck must only be operated in Manual mode until the problem is completely resolved. Components used for Assistance mode include the safety laser scanner, movement tracking sensors, foot protection sensors (variant), 3D front view camera (variant), control components, control electronics and control software, emergency off switches, LED signalling unit, switches and remote control.

Trucks that are not safe for operation or for use on the road must not be used until they have been properly repaired.

Do not remove or deactivate safety systems and switches.

No additional bores may be made on the safety components and the truck chassis.

The contractually agreed set values for Assistance mode may be changed only by qualified personnel at the manufacturer who have been trained to complete this work.

Work on the electrical system (e.g. additional headlights) is only permitted with the manufacturer's written approval. All work carried out on the electrical system must be documented.

## Medical equipment

### **WARNING**

Electromagnetic interference may occur on medical devices!

Only use equipment that is sufficiently protected against electromagnetic interference.

---

Medical equipment, such as pacemakers or hearing aids, may not work properly when the truck is in operation.

- Ask your doctor or the manufacturer of the medical equipment to confirm that the medical equipment is sufficiently protected against electromagnetic interference.

## Residual risk

# Residual risk

## Residual dangers, residual risks

Despite working carefully and complying with directives and standards, the possibility of other dangers occurring when operating the truck in Assistance mode cannot be entirely excluded.

The system components used for Assistance mode comply with current safety requirements. Nevertheless, some residual risk cannot be excluded, even when the truck is used for its intended purpose and all instructions are observed.

Even beyond the narrow danger area of the truck itself, a residual risk cannot be excluded when operating the truck in Assistance mode. Persons and drivers of other trucks must exercise a heightened degree of awareness regarding the truck, so that they can react immediately in the event of any malfunction, incident or breakdown etc.

### WARNING

All persons that are in the vicinity of the truck must be instructed regarding the dangers that arise from a truck operating in Assistance mode.

In addition, your attention is drawn to the safety regulations given in these operating instructions.

Additional risks that may arise when operating the truck in Assistance mode include:

- Risk of accident due to obstructed or blind roadways
- Risk of accident due to poor operator visibility over the working area
- Risk of accident due to an unsuitable working environment that the scanner cannot detect, e.g. operation in unsuitable warehouse aisles
- Risk of accident as a result of objects protruding into the driving area that the safety laser scanner cannot detect (e.g. obstacles above or below the scanner range)
- Accidental operation of the remote control by the operator, e.g. if the remote control is carried in a trouser pocket / jacket pocket, or if objects are placed on top of the remote control

- Risk of accident at bottlenecks (e.g. narrowed aisles, obstacles on the roadway) if a small safety distance is parameterised on the opposite side of the roadway to which the truck is aligned
- Human error resulting from failure to observe the safety regulations
- Unrepaired damage or faulty and worn components
- Work performed on components in the system by unauthorised persons
- Insufficient maintenance and testing of safety components
- Testing intervals for safety components exceeded
- Risk of accident if the truck automatically restarts movement following an emergency stop when operating in Assistance mode
- Risk of accident when objects are not detected by the foot protection sensors in impermissible or poor ambient conditions

The manufacturer accepts no responsibility for accidents involving the truck caused by the failure of the operating company or the operator to note these risks either intentionally or due to lack of care.

### Overview of hazards and countermeasures

**i** NOTE

*This table is designed to help operators evaluate the hazards present in Assistance mode. It does not claim to be complete.*

- Observe the national regulations for the country in which the truck is being used.

Hazard	Course of action	Check note √ done - Not applicable	Notes
For transport systems with an assistance system for driverless operation			
Roadway quality inadequate	Clean/clear roadways	○	BetrSichVO (Workplace Safety Ordinance)

## Residual risk

Hazard	Course of action	Check note √ done - Not applicable	Notes
Load-carrying equipment incorrect; load could slip	Reposition load on pallet	○	BetrSichVO (Workplace Safety Ordinance)
Unpredictable driving behaviour	Employee training	○	BetrSichVO (Workplace Safety Ordinance)
Roadways blocked or (temporarily) closed	Mark roadways Keep roadways clear	○	BetrSichVO (Workplace Safety Ordinance)
Roadways intersect in a mix of Assistance / Manual mode	Announce right-of-way rule	○	BetrSichVO (Workplace Safety Ordinance)
Limitations to the person detection function due to the environment scanner in Assistance mode	Employee training	○	BetrSichVO (Workplace Safety Ordinance)
Obstacles such as ladders and working platforms within the movement area of the truck, e.g. for performing repair or maintenance work in the aisle	Close off roadways to the affected movement or working areas using cones. There must be no driverless trucks in the closed-off area.	○	BetrSichVO (Workplace Safety Ordinance)
Risk of accident when objects are not detected by the foot protection sensors in impermissible or poor application conditions, e.g. a contaminated or uneven area of use, mist or other view-obstructing vapours, failure to wear work shoes or work shoes that are too small	Establish application conditions in accordance with these operating instructions Employee training		



Hazard	Course of action	Check note √ done - Not applicable	Notes
Obstacles that are crosswise to the roadway or that protrude into the roadway that cannot be detected by the safety systems on the truck.	Employee training	○	BetrSichVO (Workplace Safety Ordinance)
Bottlenecks (e.g. narrowed aisles, obstacles on the roadway) if a small safety distance is parameterised on the opposite side of the roadway to which the truck is aligned.	Employee training Suitable protective measures in the vicinity of bottlenecks may include: – Floor markings – Warning signs	○	BetrSichVO (Workplace Safety Ordinance)

## Danger to employees when "Assistance" mode is used

According to the German workplace safety ordinance (BetrSichVO) and labour protection law (ArbSchG), the operating company must determine and assess hazards during operation, and establish the occupational health and safety measures required for employees (BetrSichVO). This investigation must also include any hazards that arise as a result of using Assistance mode. The operating company must therefore draw up appropriate operating instructions (§ 6 ArbSchG) and make them available to the operator. A responsible person must be appointed.

### NOTE

*Please note the definition of the following responsible persons: "operating company" and "operator".*

The construction and equipment of the truck correspond to the Machinery Directive 2006/42/EC and are therefore marked with CE labelling. These elements are therefore not included in the hazard assessment. Attachments possess their own CE labelling and likewise are not included for that reason. However, the operating company must select the type and equipment of the truck so as to comply with the local provisions for deployment.

## Residual risk

The result must be documented (§ 6 ArbSchG). In the case of applications involving similar hazard situations, it is permitted to summarise the results. The overview in the chapter entitled "Overview of hazards and countermeasures" provides advice on complying with this regulation. The overview specifies the primary hazards that, in the event of non-compliance, are the most frequent causes of accidents. If other major hazards are present as a result of the specific operating conditions, these hazards must also be taken into consideration.

The conditions of use for the truck are broadly similar in many plants, so the hazards can be summarised in one overview. Observe the information provided by the relevant employers' liability insurance association on this subject.

## Safety tests

### Regular safety inspection of the truck

#### Safety inspection based on time and extraordinary incidents

The operating company must ensure that the entire truck is inspected by a qualified person at least once a year or after unusual incidents.

As part of this testing of the entire truck, the condition and function of the components used for Assistance mode must also be checked.

The testing of these components may be performed only by the authorised service centre. The person performing the testing in the authorised service centre must have sufficient knowledge and experience to be able to assess the condition of the truck and the effectiveness of the devices according to technical conventions and the principles for testing industrial trucks. The basis for the additional testing is provided by the separate "Assistance" test log book.

In addition to the test log for the entire truck, the authorised service centre prepares a separate "Assistance" test log. The "Assistance" test log contains the test results for the components used for Assistance mode. The results of the testing must be retained at least until a further two inspections have been carried out.

It is the responsibility of the operating company to have defects rectified immediately by the authorised service centre.

## Emissions

### NOTE

*The emissions values correspond to the values listed in the standard operating instructions.*

## Labelling points

## Labelling points

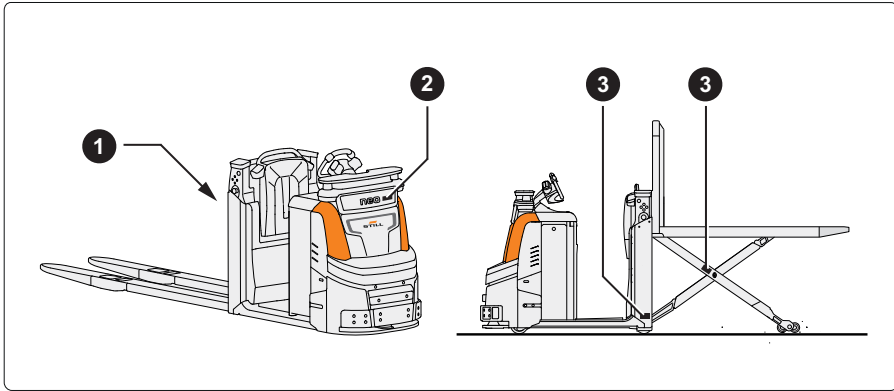

1 Warning sign: Lifting of persons with the forks is prohibited

2 Information sign: "Easy Protect" collision avoidance (variant)

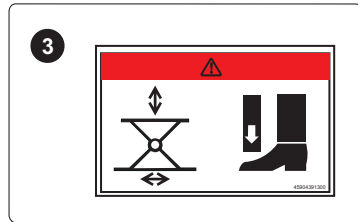

3 Warning sign: Risk of feet being crushed by the pantograph lift (OPX-L 20 S)

**3**

---

## **Components of the iGo neo**

## Overview of components used for "Assistance" mode

## Overview of components used for "Assistance" mode

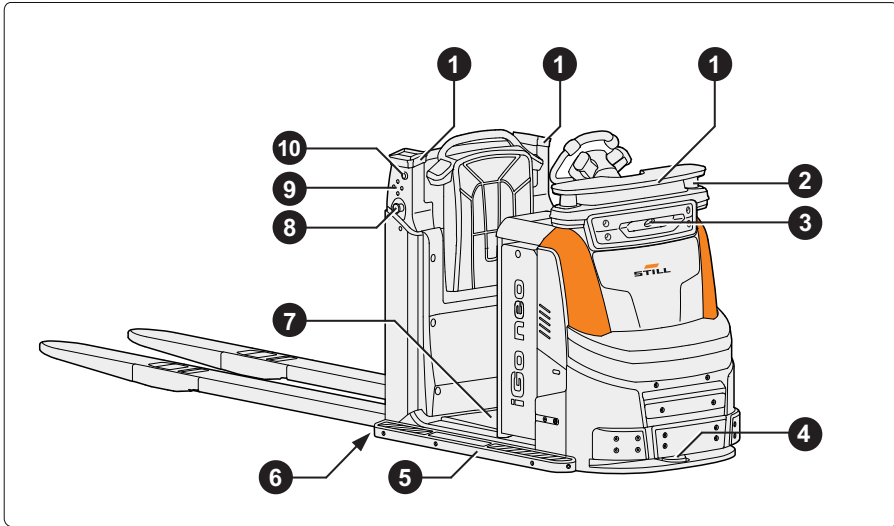

- |   |  |    |   |
|---|--|----|---|
| 1 | LED signalling units   | 8  | Additional emergency off switches (left and right-hand side of the truck) |
| 2 | Movement tracking sensors (left-hand and right-hand side of the truck) | 9  | Keypad (on the left-hand side and right-hand side of the truck):          |
| 3 | 3D camera, e.g. for "Easy Protect 3D" (variant)                        | ▲▼ | Lift/lower the fork carriage  |
| 4 | Safety laser scanner   | ▶◀ | Move the stop position next to the operator                               |
| 5 | Chassis extension for wide pallets (variant)                           | 10 | IGO neo button (left and right-hand side of the truck)                    |
| 6 | Foot protection sensors (variant)                                      |    |   |
| 7 | Driver platform  |    |   |

## LED signalling units

### Information signals and warning signals on the LED signalling units

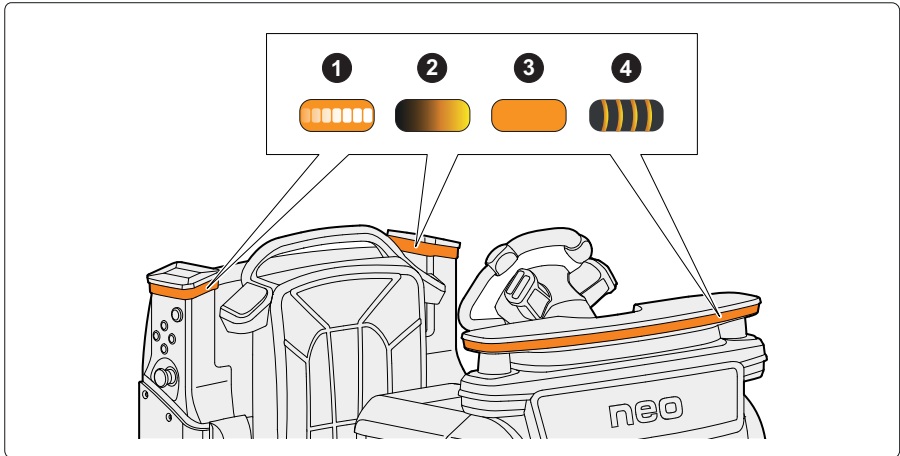

Signal	Truck function signalled
<b>1</b> Lighting zone indicates the truck alignment	Truck in Assistance mode <ul style="list-style-type: none"> <li>• The truck aligns itself with the displayed side of the aisle</li> </ul>
<b>2</b> Lighting zone pulsates slowly (approx. 1 x per second)	Truck in Manual mode <ul style="list-style-type: none"> <li>• Operator is on the driver's platform and is operating the truck manually</li> </ul>
<b>3</b> Lighting zone remains permanently lit	Remote control is not connected to the truck <ul style="list-style-type: none"> <li>• Remote control switched off or battery empty</li> <li>• Connection was not active for a long time and needs to be re-established</li> </ul>
<b>4</b> Light signal flashes rapidly (approx. 10 x per second)	Emergency stop <ul style="list-style-type: none"> <li>• Truck is stationary; triggered by the safety laser scanner or by pressing the emergency off switch</li> </ul>

#### NOTE

"Easy Protect" (variant) for collision avoidance:

- Observe additional LED signals in Manual mode, see the chapter entitled "Collision avoidance Easy Protect (variant)".

## LED signalling units

## Truck alignment display on the LED signalling units

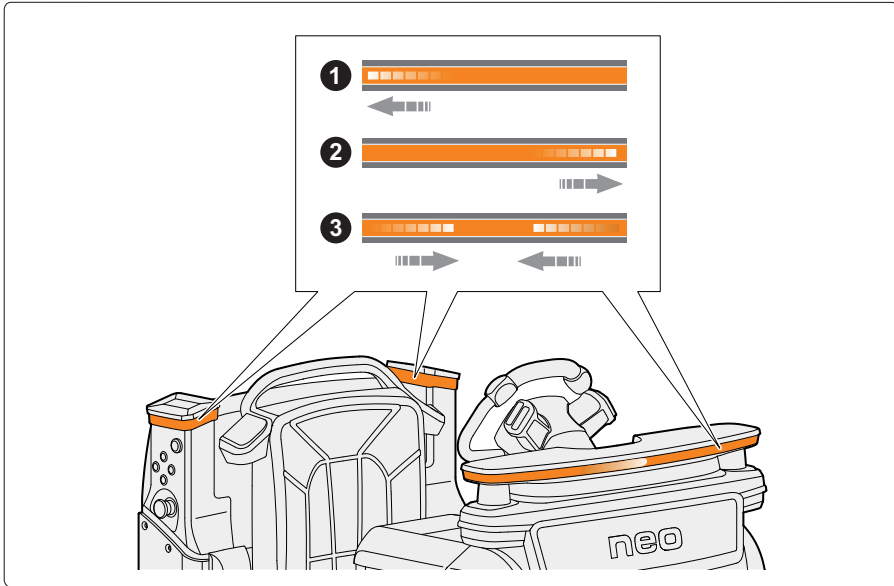

The truck alignment is the side of the aisle to which the truck is oriented in Assistance mode. The operator can use the remote control to set the RIGHT, LEFT and MIDDLE truck alignment settings.

A moving light spot on the LED signalling units indicates the selected truck alignment.

Signal		Truck function signalled
①	Light spot moves to the left along the lighting zone	Truck alignment LEFT <ul style="list-style-type: none"> <li>• Truck maintains a constant distance to the rack contour on the left</li> </ul>
②	Light spot moves to the right along the lighting zone	Truck alignment RIGHT <ul style="list-style-type: none"> <li>• Truck maintains a constant distance to the rack contour on the right</li> </ul>
③	Light spot moves towards the middle along the lighting zone	Truck alignment MIDDLE <ul style="list-style-type: none"> <li>• Truck moves in the middle between the two rack contours</li> </ul>



## Operator detection

### Operator detection system

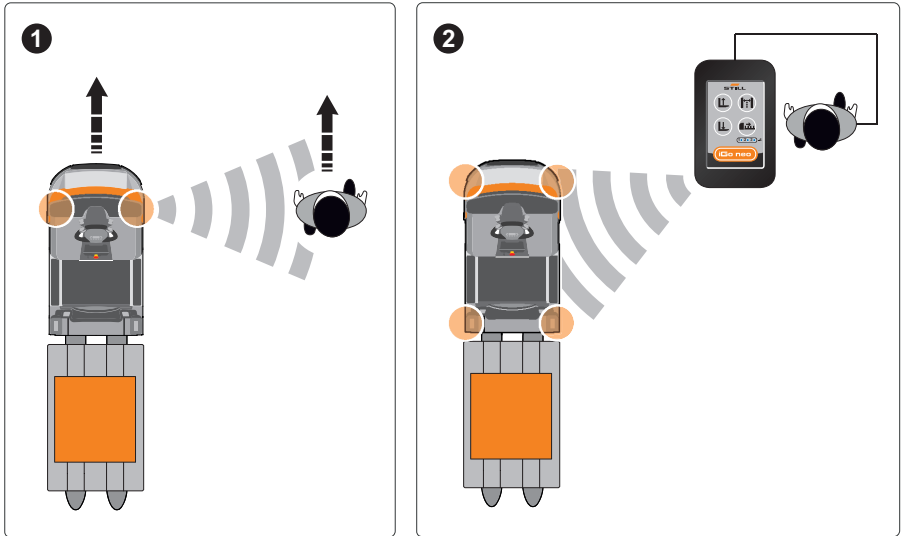

For movement tracking of the operator to be able to function, the truck has to identify the operator and track the operator's current position.

Two truck systems work together to achieve this:

- 1 The movement-tracking sensors
- 2 The position tracking of the remote control

To protect the remote control, it must be carried in the supplied holder when the truck is operated in Assistance mode.

## Operator detection

### Movement tracking sensors

The truck uses the two movement tracking sensors (1) to track the position of the operator. In combination with the position tracking of the remote control, reliable detection of the operator is guaranteed.

The sensors capture the area around the truck within a visible radius of max. 15 m. The light from the sensors is not dangerous to the human eye.

The LED signals from the movement tracking sensors show the status of Assistance mode. The symbols shown always point in the direction of the operator.

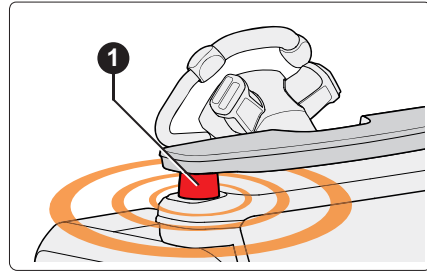

### LED signals from the movement tracking sensors

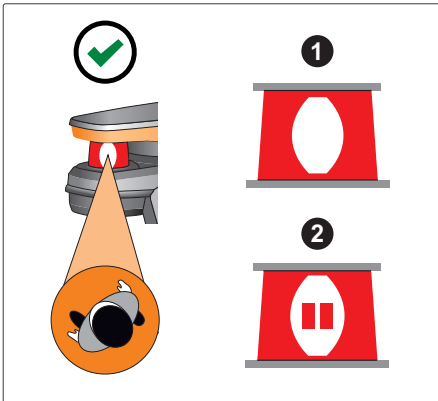

#### Operator currently detected

Symbols filled in white

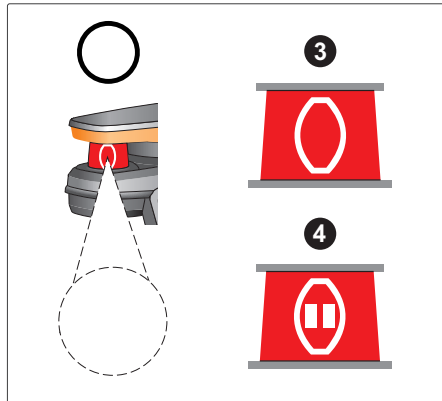

#### Operator not currently detected

Symbols with white outline

Symbol / meaning	Information
① Assistance mode ACTIVE ("Eye" symbol)	The truck follows the operator
② Assistance mode PAUSED ("Pause" symbol)	The truck does not follow the operator

Symbol / meaning	Information
<p>③ Operator not identified. ("Eye" symbol/contour)</p>	<p>The truck follows the operator</p> <ul style="list-style-type: none"> <li>• No exact approach to the selected stop position next to the operator. The truck always stops next to the operator at the height of the side signal lights</li> <li>• As soon as the operator is detected again: normal Assistance mode ACTIVE</li> </ul>
<p>④ Operator not identified. ("Pause" symbol/contour)</p>	<p>The truck does not follow the operator</p> <ul style="list-style-type: none"> <li>• As soon as the operator is detected again: Assistance mode PAUSED</li> </ul>

### Position tracking of the remote control

The truck uses the position tracking of the remote control to identify and track the position of the operator. In combination with the movement-tracking sensors, reliable detection of the operator is guaranteed at all times.

A transmitter operates inside the remote control. The position of this transmitter is permanently determined by four receivers (1) in the truck. The truck simultaneously uses the signal to identify the carrier of the remote control as the operator.

The position tracking detects the operator in a radius of max. 15 m around the truck.

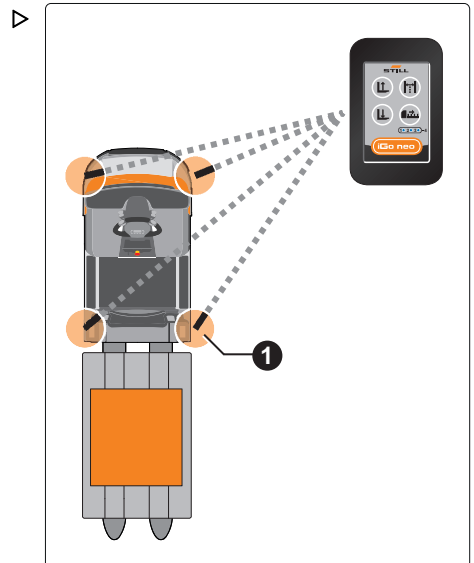

## Laser scanner

## Laser scanner

## Function of the safety laser scanner

The safety laser scanner (1) detects the rack contour and the surrounding environment. Using the spatial data, the truck can automatically follow the operator along the rack contour.

The safety laser scanner checks the roadway for obstacles while the truck is in motion.

- If the scanner detects an obstacle on the side of the roadway to which the truck is aligned, the truck automatically drives around the obstacle. The truck then continues on its path
- If an obstacle is too large to avoid, the truck will stop. The truck continues on its path as soon as the obstacle is removed
- If an obstacle enters the protective field of the safety laser scanner, the truck performs an emergency stop

The safety laser scanner poses no risk of damaging the human eye.

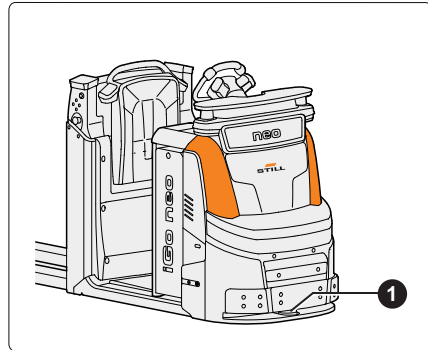

## Size and location of the monitored area

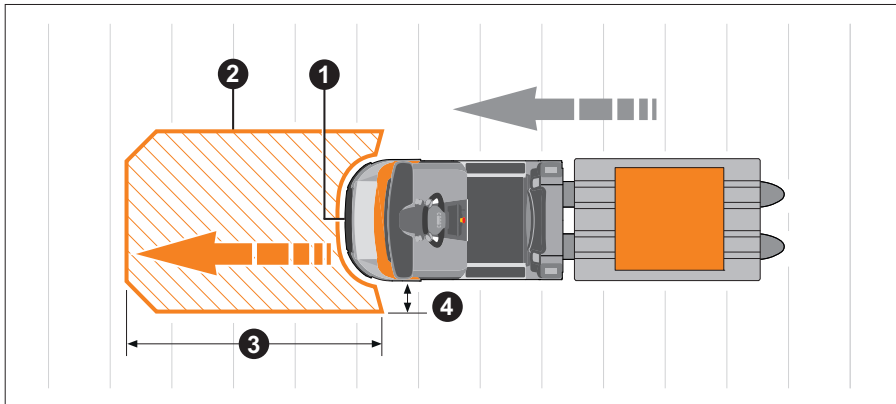

The safety laser scanner (1) monitors the area (2) in front of the truck.

- In the drive direction, the size of the monitored range depends on the current speed. At higher speeds, the monitored area (3) in front of the truck also increases
- The monitored area at the side (4) extends beyond the truck contour

The safety laser scanner detects objects horizontally at a height of 9 cm above the ground. ▷

- Observe the notes in the chapter entitled "Collision avoidance / limits to the detection of obstacles".

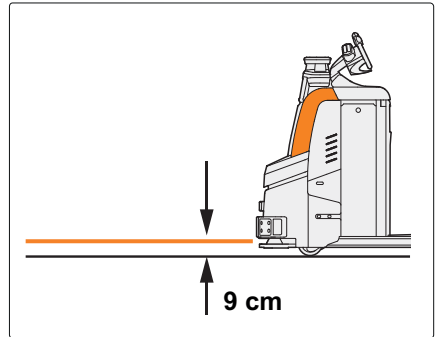

## Foot protection sensors

## Foot protection sensors

## Function of the foot protection sensors (OPX-L 20 S) ▷

The foot protection sensors (1) are only installed on truck variants with a pantograph lift. They are located on both sides next to the lower fixing point of the pantograph lift on the truck.

In Assistance mode, the operator can lower the forks with the remote control. When the fork carriage is raised, the foot protection sensors check the area under the forks.

If an obstacle is detected under the forks when the truck sets off, the truck will not set off or will stop again immediately. This protects the feet of the operator from being driven over by the load castors of the forks.

However, the operator can still lower the forks.

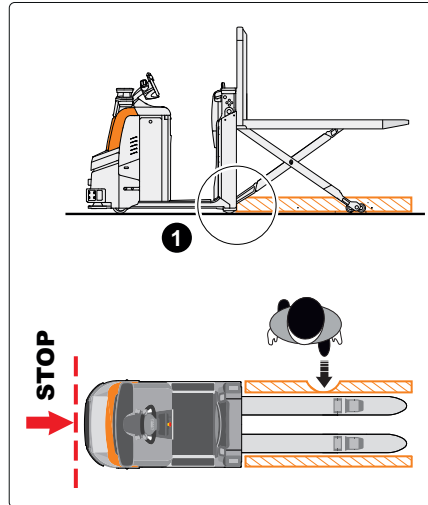
**NOTE**

*The truck does not stop for objects under the forks if it is already in motion.*

The warning signs (2) tell the operator to keep their feet away from the area around the pantograph lift at all times. ▷

**⚠ WARNING**

Risk of injury in areas not covered by the foot protection sensors

The area between the forks and the area above a lift height of 50 cm are not covered. There is a risk of injury in these areas.

- Do not enter the area between the forks.
- Keep hands and feet away from the mechanism of the pantograph lift.

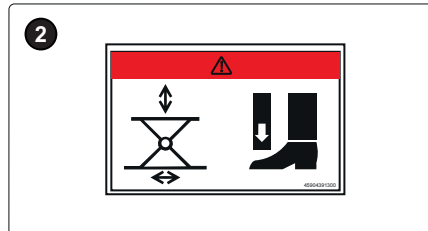

**Warning sign: Risk of feet being crushed in the vicinity of the pantograph lift**



## Keypad on the side of the truck

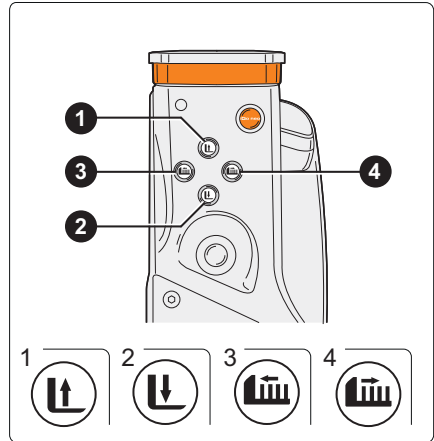

### Functions of the keypad on the side of the truck

**i NOTE**

The functions performed using the keypad on the side of the truck can also be carried out via the appropriate buttons or the remote control.



Lift and lower the fork carriage (standard assignment)	
Button 1 (  )	Lift the fork carriage *
Button 2 (  )	Lower the fork carriage *
* See the chapter entitled "Lifting and lowering the fork carriage"	

Move the stop position next to the operator (standard assignment)	
Button 3 (  )	Move the stop position next to the operator (in the direction of the drive side) *
Button 4 (  )	Move the stop position next to the operator (in the direction of the load side) *
* See the chapter entitled "Moving the stop position next to the operator"	

The authorised service centre can configure the assignment of the keypad.

## iGo neo buttons

## iGo neo buttons

## Functions of the iGo neo buttons

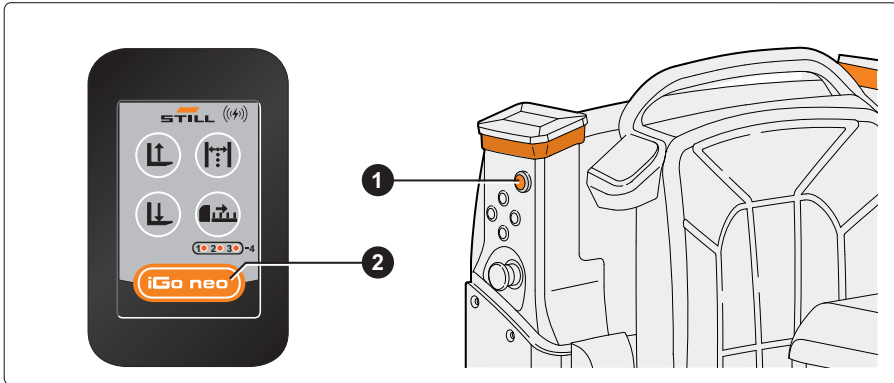

1 iGo neo button (left and right side of the truck)

2 iGo neo button (remote control)

Using the iGo neo buttons, the operator can switch between the ACTIVE and PAUSED states for Assistance mode. When an iGo neo button is pressed, the operator is identified.

iGo neo buttons ①, ②	Assistance mode		
Push 1 x <b>briefly</b>	When the truck is stationary:		
	PAUSED	→	ACTIVE
	When the truck is in motion:		
Press and <b>hold</b> once until you hear the signal tone	ACTIVE	→	PAUSED

Additional functions of the two iGo neo buttons are described in the chapters about operating the iGo neo, see the chapter entitled "Operating the truck in Assistance mode".



## Emergency off switch

### Additional emergency off switches

The truck is equipped with additional emergency off switches (1) (left and right-hand side of the truck).

- In the event of imminent danger to people, the load or the truck, press one of the emergency off switches immediately. This is the fastest way to bring the truck to a standstill.

When the emergency off switch is pressed, the truck performs an emergency stop (refer to the chapter entitled "Truck behaviour in the event of an emergency stop").

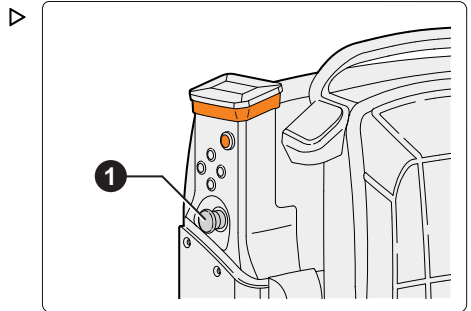

## Remote control

## Remote control

## Functions of the remote control ▷

## Switching the remote control on and off

- To switch the remote control on, push the iGo neo button (1).
- To switch off the remote control, simultaneously press the "lift" and "lower" buttons for several seconds.

The remote control switches off automatically:

- When the truck is switched off and the set run-on time of the robotics system has expired (can be set by the authorised service centre).
- When the remote control is being charged.

## Display LEDs on the remote control

The display LEDs (6) switch on when the remote control is switched on.

- If the remote control is connected to the truck, the stop position (1 - 2 - 3 - 4) of the truck next to the operator is indicated
- If the remote control is **not** connected to the truck, the battery charge level of the remote control is indicated (the LEDs flash)



- 1 Assistance mode ACTIVE / PAUSED
- 2 Lower the fork carriage
- 3 Lift the fork carriage
- 4 Switch the truck alignment in sequence
- 5 Move the truck stop position next to the operator to the next pallet
- 6 Display LEDs

## Remote control vibration signals

Information	Signal
Connecting the remote control to the truck	Three long pulses
Truck moves off <ul style="list-style-type: none"> <li>• after being at a standstill for more than two seconds</li> <li>• after an emergency stop or Assistance mode is switched to PAUSE</li> </ul>	One short pulse
Battery charge level very low (below 20%)	Three short pulses (every three minutes)
Battery charge level exhausted, remote control switches off	One long pulse

## Remote control buttons

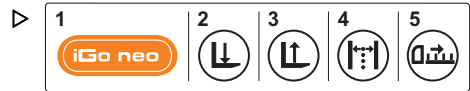

Button ❶ - Assistance mode ACTIVE / PAUSED (iGo neo button)

Operating	Assistance mode		
Push 1 x <b>briefly</b>	When the truck is stationary:		
	PAUSED	→	<b>ACTIVE</b>
Press and <b>hold</b> once (until signal tone)	When the truck is in motion:		
	<b>ACTIVE</b>	→	PAUSED

Button ❶ - Driving automatically without movement tracking (iGo neo button)

Operating	Information
Press and hold the button (min. 2 sec.).	The truck moves independently along the rack contour until the button is released. Can only be executed during "Assistance mode PAUSED"

Button ❷ - Lower the fork carriage

Button ❸ - Lift the fork carriage

Operating	Information
Hold the button down.	Release the button. Fork stops. <sup>1)</sup>
Push once briefly.	Fork moves for one second or until the next defined lift height. <sup>1)</sup>
<sup>1)</sup> See also the chapter entitled "Lifting and lowering the fork carriage"	

Button ❹ - Switch truck alignment (LEFT / RIGHT / MIDDLE)

Operating	Information
LEFT / RIGHT: Briefly push the button.	Can only be executed when the truck is stationary.
MIDDLE: Long press the button (min. ½ sec.)	

Button ❺ - Move the truck stop position next to the operator

Operating	Information
Briefly push the button.	Moves the position at which the truck automatically stops next to the operator along to the next position. Can only be executed during "Assistance mode PAUSED".

## Remote control

## Charging the remote control

**NOTE**

*A new remote control must be fully charged after it is delivered to ensure that its battery charge is correctly displayed.*

## Checking the battery charge of the remote control

If the remote control is not connected to the truck, the display LEDs on the remote control indicate the battery charge level.

- To check, switch off the truck or move far enough away from the truck so that the connection to the remote control is interrupted.
- Switch the remote control off and on again.

The display LEDs on the remote control will now show the battery charge level:



## Battery charge display

	100% - 90%	90% - 60%	60% - 30%	30% - 0%
<b>LED 1</b>	Flashing	On	On	Flashing
<b>LED 2</b>	Flashing	On	Flashing	-
<b>LED 3</b>	Flashing	Flashing	-	-

When the battery charge drops below 30% (LED 1 flashing), the remote control must be charged.

If the battery charge level drops to 0%, the remote control switches off. In *Assistance* mode, the truck either will not set off or will come to a stop. The truck can be moved only in *Manual* mode.

The minimum runtime of the remote control on a fully charged battery is 18 hours. Keeping the remote control charged prolongs the life cycle of the rechargeable batteries.

**NOTE**

*The remote control is designed for up to two shifts on a full charge. In heavy-duty applications, intermediate charging is recommended.*

### Charging the remote control

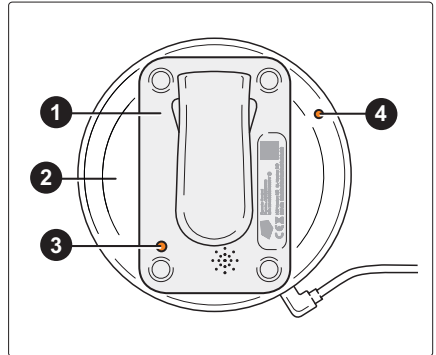

#### Notes on charging

- For a quick charge, the remote control (1) must be centred and rest directly on the charging pad (2).
- High temperatures reduce the charging speed. It is recommended to charge the remote control at ambient temperatures below 25°C. The maximum ambient temperature during charging is 40°C.
- Keep the charging pad clean. Only clean the charging pad with a dry cloth or brush.
- Remove foreign objects on the charging pad. Foreign objects can cause the charging process to fail or the charging pad to overheat during charging.

The remote control is inductively charged with the charging pad supplied.

- Connect the charging pad.
- Place the remote control on the centre of the charging pad with the keypad facing down.

The display LEDs on the remote control (3) and the charging pad (4) indicate the progress of the charging process.

#### Display LED on the remote control (back)

Display LED	Information
Red (flashing)	Battery charge under 90%
Green (flashing)	Battery charge between 90% and 99%
Green	Battery fully charged (100%)

#### Display LED on the charging pad

Display LED	Information
Blue (goes out after three seconds)	Charging pad has just been connected to the power supply
Blue (steady)	Remote control is charging
Blue (flashing)	Foreign objects detected on the charging pad (e.g. metal objects)
Green (flashing)	Excess voltage protection (only use 5 V / 9 V DC adapters)

## Remote control

### Changing the remote control

Each remote control has a unique pairing code that is defined by the manufacturer. Remote controls are only able to control the truck if the relevant pairing code has been recognised by the receiving unit. This prevents non-registered remote controls from accessing the truck.

If a truck is to be controlled using a new or additional remote control, the pairing code for the remote control must first be saved in the receiving unit on the truck.

Each receiving unit can save a maximum of 20 pairing codes. If there are already 20 pairing codes present and more codes need to be saved, all existing pairing codes must first be deleted. Individual pairing codes cannot be deleted from the memory of the receiving unit.

If multiple remote controls that are registered to a truck attempt to access the truck simultaneously, the remote control that first made contact with the truck retains control. Other remote controls do not receive access until the first remote control has stopped transmitting.

### Registering a new or additional remote control on the truck

- Contact the authorised service centre to register a remote control on the truck.

4

---

## Operating the iGo neo

## Checks and tasks to be carried out when commencing "Assistance" mode

**Checks and tasks to be carried out when commencing "Assistance" mode****Safety information for carrying out the tests****⚠ WARNING**

Damage or other defects to the components used for Assistance mode can result in accidents.

If damage or other defects are identified on the components during the following inspections, the truck must not be used until it has been properly repaired. Do not open, remove or deactivate components for Assistance mode. Do not change any predefined set values.

- Report defects to the supervisory personnel.

When commencing Assistance mode, the operator must ensure that the components used for Assistance mode are safe for operation. To do this, the following tests in this chapter must be performed.

**Visual inspections before switching on "Assistance" mode**

Before switching on Assistance mode, the operator must perform the following visual inspections:

Visual inspections before switching on Assistance mode	
•	The protective guard on the front of the truck that protects the safety laser scanner against mechanical damage must be undamaged. The alignment and the scanner's field of vision must not be impaired
•	The mountings for the movement tracking sensors must not be damaged. The alignment of the sensors must not be impaired
•	The mountings for the foot protection sensors must not be damaged. The alignment of the scanners must not be impaired
•	The LED signalling units and their mountings must not be damaged
•	The optics covers (inspection windows) in front of the safety laser scanner, the foot protection sensors and the movement tracking sensors must be free of dirt, scratches and damage.
•	The safety laser scanner, the foot protection sensors and the movement tracking sensors must not be manipulated, e.g. glued or otherwise concealed.



## Checks and tasks to be carried out when commencing "Assistance" mode

Visual inspections before switching on Assistance mode	
•	All covers must be present and sealed
•	The remote control must be undamaged and charged. To protect the remote control and to prevent operating errors, the remote control must be carried in the supplied holder when the truck is operated in Assistance mode.

- Report defects to the supervisory personnel. Do not use the truck until it has been properly repaired

## Checks after switching on "Assistance" mode

### Safety brake test after switching on "Assistance" mode

After switching on Assistance mode, the operator must perform a check to ascertain whether the truck automatically stops in front of an obstacle.

- Stop the truck in front of an unobstructed, straight section of roadway.
- Place a suitable test object (with an edge length and height of at least 20 cm) one metre in front of the truck.
- Move off the driver's platform and move the truck using the remote control so that it approaches the test object.

The truck must automatically come to a standstill just in front of the obstacle.

- Report defects to the supervisory personnel and do not use the truck until it has been properly repaired.

### Checking the "Easy Protect" collision avoidance (variant) after switching on the truck

After switching on the truck, the operator must check the function of "Easy Protect" once. The truck must reduce speed when approaching an obstacle in Manual mode.

- Switch on the truck. Wait until "Easy Protect" is ready for operation.

## Checks and tasks to be carried out when commencing "Assistance" mode

- In manual mode, drive slowly towards an obstacle (edge length and height of at least 20 cm).
- Check that the truck automatically reduces speed before reaching the obstacle.
- Steer around the obstacle. The truck must now be able to accelerate again without restriction.
- Report defects to the supervisory personnel and do not use the truck until it has been properly repaired.

### Function checking of the side emergency off switches after switching on "Assistance" mode

After switching on Assistance mode, the operator must check that the two side emergency off switches are working.

- Push and release the two side emergency off switches one at a time.

When the emergency off switches are pushed, the truck must respond as follows:

Truck response when emergency off switch is pressed	
•	The electromagnetic truck brake is audibly applied
•	The LED signalling units display the "emergency stop" signal
•	The truck emits the audible "emergency stop" warning sound

After releasing the emergency off switches and restarting the system, the movement tracking sensors must show "Assistance mode PAUSED".

**Function checking of the foot protection sensors after switching on "Assistance" mode (OPX-L 20 S)**

After switching on Assistance mode, the operator must check that the two side foot protection sensors are working. If the foot protection sensors detect an object under the forks, the truck does not move off or responds with an emergency stop. However, the operator can still lower the forks.

The foot protection sensors are only installed in trucks with a pantograph lift (OPX-L 20 S). They are located on both sides next to the lower fixing point of the pantograph lift on the truck.

The yellow display LED on the foot protection sensor (1) lights up when an object is detected in the area below or next to the forks.

- Lift the forks approximately 20 cm.
- Walk in the area to the right of the raised forks and observe the display LEDs on the foot protection sensor.
- Place one foot parallel to the fork in the area **next** to the fork. Do not lower the fork.
  - When the foot protection sensor detects your foot correctly, the yellow display LED lights up.
- Repeat the test on the left side of the truck.

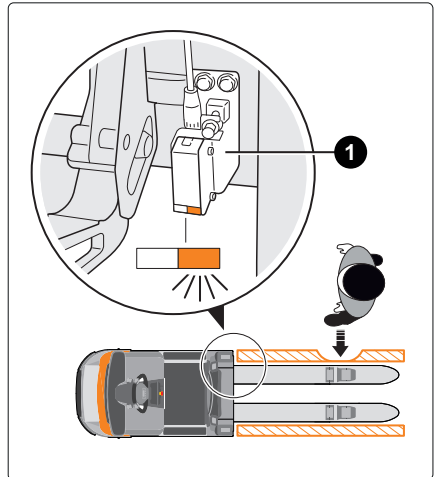

**Function checking of the foot protection sensors**  
**1** Foot protection sensor with yellow display LED

**Visual inspections after switching on "Assistance" mode**

After switching on Assistance mode, the operator must check the following truck functions during operation:

Visual inspections when Assistance mode is active	
•	Check that the truck responds correctly to entries made with the remote control
•	Check that the warning signals and information signals function in Assistance mode <sup>(1)</sup>
•	Check that the set minimum distances to the rack and to obstacles in the roadway are observed
•	Only after a change to the crosswise roadway settings by the authorised service centre: Make sure that the truck detects the crosswise roadways and stops automatically

## Checks and tasks to be carried out when commencing "Assistance" mode

- (1) Information signals and warning signals are part of the safety concept. These signals provide important information for people in the working area as they indicate that there is a driverless truck close by. The signals will help to avoid accidents. See the chapter entitled "Information signals and warning signals in Assistance mode".
- Report defects to the supervisory personnel. Do not use the truck until it has been properly repaired

## Safety regulations in "Assistance" mode

### Instructions for the safe operation of the iGo neo

#### Wear safety shoes

In the interest of safety, the operator and people in close proximity to the truck must wear work safety shoes in the correct size while the truck is being operated.

#### Observe the risk of feet being crushed when lowering the forks

##### DANGER

##### **Risk of feet being crushed by the forks of the truck**

When the truck moves off in *Assistance* mode or when lowering the load, feet can be crushed if they project beneath the forks.

- Keep your feet a safe distance away from the forks. Pay attention to the warning sound from the truck when the truck moves off in *Assistance* mode.
  - Wear suitable work safety shoes in the correct size.
-

## Safety regulations in "Assistance" mode

Observe the limitations of the foot protection sensors in the event of impermissible or poor application conditions (OPX-L 20 S)

### **⚠ DANGER**

**Risk of feet being crushed in the event of impermissible or poor application conditions**

In the event of impermissible or poor application conditions, the foot protection sensors may not reliably detect objects in certain situations.

These situations include the following:

- Uneven ground (operator's foot is in a depression)
- The truck is raised on an object (e.g. piece of wood)
- Heavily contaminated area of use
- Smoke, mist or other view-obstructing vapours
- In the event of impermissible or poor application conditions, only operate the truck in Manual mode.
- Always keep feet away from the area under the forks.
- Observe the warning signs (1) on the truck.
- Always wear suitable work safety shoes in the correct size.

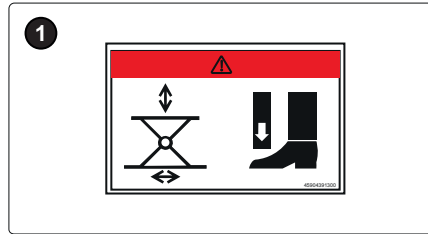

**Warning sign: Risk of feet being crushed in the vicinity of the pantograph lift**

## Averting the risk of collision using the emergency off switches

### **⚠ CAUTION**

Averting the risk of collision using the emergency off switches

If there is a risk of collision with persons or objects, push one of the emergency off switches on the truck. The truck stops immediately.

## Switch "Assistance" mode to PAUSED before entering the truck

### **⚠ WARNING**

When Assistance mode is switched on, the truck may move unexpectedly when the operator enters the truck. The operator may be injured as a result.

Before climbing into the truck, switch Assistance mode to PAUSE using the iGo neo button on the remote control or on the truck.

### Observe the risk of accident from crossing the roadway immediately in front of the truck

#### **⚠ DANGER**

**Danger for people or objects that quickly cross the roadway immediately in front of the truck.**

The safety laser scanner detects obstacles in the roadway in front of the truck. If a person or object quickly crosses the detection area (1) immediately in front of the truck, under certain circumstances the immediate emergency stop may not prevent a collision.

- Do not jump or step in the roadway if the truck is almost at the same level.
- Do not cross the roadway of the iGo neo with a manually operated truck if the iGo neo is almost at the same level. Note the fork length of the manually operated truck.
- The truck operating in Assistance mode always has priority. Observe lighting signals from the iGo neo.

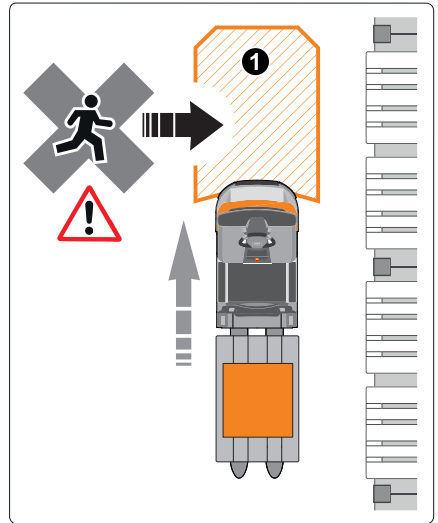

**Risk of accident from crossing the roadway immediately in front of the truck**

### Ensure that particular care is taken when there are bottlenecks in the aisle

#### **⚠ WARNING**

It is possible to set distances that are maintained between the truck and the rack contour or any obstacles. A distance of less than 50 cm can be set on the opposite side of the roadway to which the truck is aligned, if the truck is being used in narrow aisles. See the chapter entitled "Required safety distances in the aisle".

- If there are bottlenecks on the roadway, especially due to obstacles, these must be anticipated during operation.
- If the truck has to avoid obstacles, there must be no persons in the passing area. If there are persons in this area, switch Assistance mode to PAUSED immediately using the iGo neo button on the remote control or on the truck. If necessary, push the emergency off switch on the truck.
- Do not continue operation in Assistance mode until all persons have left the passing area.

## Safety regulations in "Assistance" mode

### Observing the maximum permissible dimensions of load carriers and loads

#### **⚠ DANGER**

#### **Risk of accident from load carriers and loads that protrude beyond the truck contour**

The load must not protrude beyond the truck contour in a longitudinal or lateral direction, as otherwise the load may collide with persons or the load may fall off.

- Only use suitable load carriers (refer to the chapter entitled "Requirements for load carriers and loads").

### Load individual pallets onto trucks with long forks from the side ▷

#### **⚠ WARNING**

Risk of injury in the unladen area of the fork

In the unladen area of the fork, the operator is able to get closer to the fork:

In the area behind the pallet (1) there is a risk of feet being crushed when the forks are lowered.

In the area in front of the pallet (2) there is a risk of collision with the pallet when the truck drives off.

- Always load pallets from the side.
- Do not enter the unladen area of the fork.

Trucks with long forks can transport one or two pallets.

If only one pallet is transported, the operator must always load and unload the pallet from the side. This ensures that the operator does not enter the unladen area of the fork and get injured.

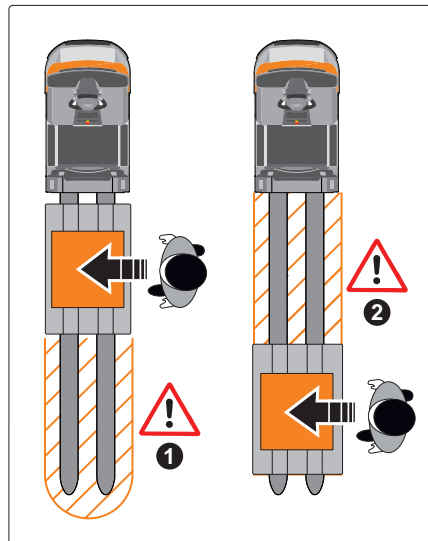

**Do not enter the unladen area of the fork in front of or behind the pallet.**



## Observe the risk of accident due to excessive speed

### **⚠ DANGER**

#### **Risk of collision due to excessive speed when operating in Assistance mode**

When operating in Assistance mode, the operator controls the driving speed of the truck via movement tracking or by using the remote control. If the speed is not adapted to the current operating situation, accidents can occur.

- When operating in Assistance mode, only allow the truck to drive at such a speed that it poses no risk to persons or objects.

## Observe information and warning signals in "Assistance" mode

### **⚠ DANGER**

#### **Risk of accident due to failure to observe warning signals**

When operating in Assistance mode, the truck emits audible and optical information signals and warning signals. The LED signalling unit provides information about Assistance mode. The warning buzzer emits an acoustic signal when the truck starts to move. The warning sound prior to moving off is issued only if the truck has been stationary for at least 10 seconds.

- Observe warning signals. Act with due care and attention

### **⚠ DANGER**

#### **Risk of accident due to faulty warning units**

When operating in Assistance mode, the truck emits audible and optical information signals and warning signals.

- Faulty components (LED signalling unit, warning buzzer) must be replaced immediately, before operation in Assistance mode is commenced or resumed.

## Safety regulations in "Assistance" mode

### Transport of people and jumping onto the truck is prohibited when operating in "Assistance" mode

#### **⚠ DANGER**

**Risk of injury for persons when travelling as a passenger or when jumping onto the truck in Assistance mode**

If people ride the truck as passengers or jump onto the truck, they are at risk of falling down or interrupting operation of the truck.

- In Assistance mode, do not travel on the truck as a passenger or jump onto the truck.

### Lifting of persons with the forks (not permitted)

#### **⚠ DANGER**

**Risk of injury when lifting persons with the forks**

- Do not use the forks to lift people.
- Never use the truck's remote control or side keypad to lift the operator or other persons with the forks.



**Warning sign on the truck: Lifting of persons with the forks is prohibited**

### Observe the risk of accident due to smoke in the event of fire or due to view-obstructing vapours

#### **⚠ DANGER**

**Risk of accident due to optical safety systems being rendered inactive by smoke in the event of fire or due to view-obstructing vapours**

The optical assistance systems (safety laser scanner, movement tracking sensors, collision avoidance camera) can be impaired by smoke in the event of fire or by other view-obstructing vapours.

- If there is smoke or other view-obstructing vapours in the area surrounding the truck, operate the truck in Manual mode only.

## Observe instructions regarding safe storage of the remote control

### DANGER

#### Risk of accident from unintentional actuation of the remote control

When the truck is switched on, the remote control must always be kept in a safe place to prevent unintentional actuation. The remote control can be actuated unintentionally, e.g. if it is carried in a trouser pocket / jacket pocket, or if objects are placed on top of the remote control.

- While operating the truck, always keep the remote control in the supplied holder.

### DANGER

#### Risk of accident if the remote control is actuated by anyone other than the operator

If anyone else actuates the remote control, the truck may move unexpectedly and injure people.

- Never give the remote control to anyone else while you are working. The remote control may only be operated by the operator.
- Never leave the remote control unattended while you are working.
- Once work has been completed, ensure that the remote control cannot be accessed by unauthorised persons.

## Observe the risk of accident due to incorrect detection of the operator

### DANGER

#### Risk of accident due to incorrect detection of the operator

In some circumstances, the truck can identify another person in the working environment as the operator. The truck may unexpectedly follow the other person for a short distance along the aisle until it detects the error.

- Immediately switch Assistance mode to PAUSE using the iGo neo button on the remote control. If necessary, push the emergency off switch on the truck.

When the truck detects the error, it stops immediately and searches for the correct operator. It continues its journey as soon as the correct operator is detected again.

## Safety regulations in "Assistance" mode

### Priority rules in mixed "Manual/ Assistance" traffic

#### DANGER

##### **Risk of collision in areas with mixed Manual/ Assistance traffic**

A truck in *Assistance* mode may not detect a second truck or may detect it too late, for example if the forks of the second truck are above or below the 9 cm scanning height of the safety laser scanner.

A truck in *Assistance* mode may start moving or stop moving unexpectedly.

- Observe the flashing and warning signals from the truck that indicate that the truck is driving or setting off in *Assistance* mode.
- Always give trucks operating in *Assistance* mode priority over trucks being driven manually.
- In areas with mixed *Manual/Assistance* traffic, always drive with extra care.

"Mixed traffic" refers to situations in which trucks in *Assistance* mode and trucks driven manually are operated in the same area.

In these areas, the following rule applies:

- Driverless trucks always have priority over manually driven trucks.

## Collision avoidance of the iGo neo

### Limits to the detection of obstacles

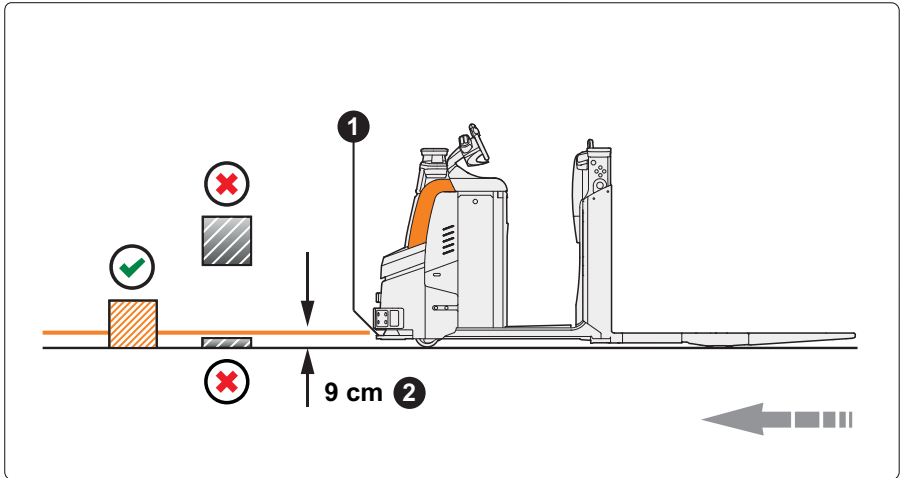

#### Detection of obstacles

- 1 Safety laser scanners
- 2 9 cm scanning height of the safety laser scanner

- ✔ Can be detected by the safety laser scanner
- ✘ Cannot be detected by the safety laser scanner

#### NOTE

The limits described here for detecting obstacles also apply to "Easy Protect" collision avoidance (variant).



#### DANGER

#### Danger of collisions with obstacles that the safety laser scanner cannot detect.

This chapter outlines the limits of the iGo neo in detecting obstacles.

- Check the roadway above all for obstacles that the safety laser scanner cannot detect and remove these obstacles.
- If there is a risk of danger, press one of the emergency off switches on the truck. The truck will immediately come to a standstill.

## Collision avoidance of the iGo neo

While the truck is in motion, the safety laser scanner horizontally scans the area in front of the truck. The scanning height is approx. 9 cm.

The safety laser scanner detects stationary objects on the ground that have the following minimum dimensions (✓ on the illustration):

- Diameter: at least 70 mm in scanning height (on the side facing the safety laser scanner)
- Height: at least 200 mm

If the safety laser scanner does not detect an obstacle because these required dimensions do not apply, the truck could ram the obstacle.

For this reason, it is necessary to pay special attention to the following obstacles (✗ on the illustration):

- Obstacles that are too low to be detected by the safety laser scanner
- Obstacles that do not reach down to the floor

Obstacles of this nature could include:

- The load on a pallet that protrudes into the roadway above the scanning height of the safety laser scanner
- A bar in a rack that protrudes into the roadway above the scanning height of the safety laser scanner
- Hand pallet trucks and their tillers, or the forks of trucks
- A cable that hangs crosswise to the roadway
- Ladders and mobile workshop hoists that protrude into the roadway
- An object that is too small or too narrow to be detected by the safety laser scanner (e.g. a narrow rack support or the leg of a chair)
- Other trucks under whose chassis the scanner can "see through".
- Trolleys whose wheels can be detected, but not the overhang.
- Bicycles that cannot be reliably detected due to narrow tyres and attachment parts.

**Be careful when driving onto or off gradients**

**⚠ DANGER**

**Risk of collision when driving onto or off gradients**

When driving onto or off gradients, the alignment of the safety laser scanner is no longer horizontal to the roadway. Under certain circumstances, obstacles may not be detected.

- Check the roadway for obstacles before driving onto or off gradients.
- Drive slowly.
- Do not drive up and down gradients in Assistance mode.

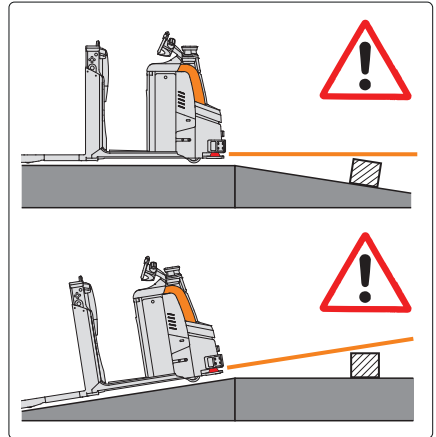

Gradients (inclines/slopes)

**Maintaining a safe distance from sloping edges and gradients**

**⚠ DANGER**

**Risk of accident from sloping edges and gradients on or in the roadway**

The collision avoidance system on the iGo neo does not check the roadway for height differences, e.g. on sloping edges, steps, platforms, ramps and gradients. The truck may tip or fall over.

- Keep a safe distance from height differences in or on the roadway.
- Do not cover difficult roadways in Assistance mode.

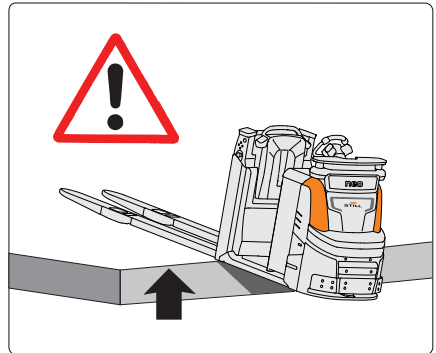

Sloping edges and gradients

## Collision avoidance of the iGo neo

### Overhang for obstacles

The safety laser scanner may not be able to detect an overhang of trucks, trolleys or objects.

If the iGo neo is used in the vicinity of objects with an overhang (1), an increased safety distance is required.

The authorised service centre can set a safety distance, (X), which takes the overhang of objects into account.

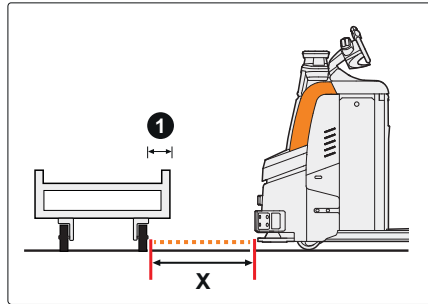
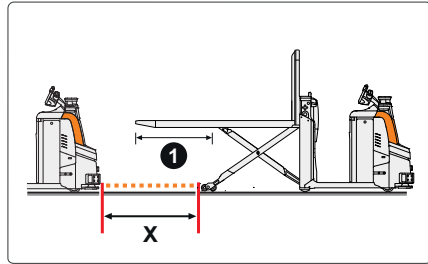



## Keeping roadways clear of obstacles

### DANGER

**Risk of accident in the event of additional work being performed in the roadway that could impede collision avoidance, e.g. in the form of people on ladders and lifting platforms.**

- If additional work is being performed in the working area, close off the roadways using cones at a maximum distance of 1.0 m.
- The cones must have a minimum height of 200 mm so that they can be reliably detected by the safety laser scanner.

### CAUTION

Increased danger of collisions with objects that the safety laser scanner cannot detect.

The safety laser scanner covers only the area close to the ground. Objects in the roadway that extend more than approx. 9 cm in height above the ground pose an increased risk of accidents. The truck does not brake automatically in such instances.

- Before moving the truck, check the roadway for obstacles that the safety laser scanner cannot detect. Pay particular attention to objects that extend laterally into the roadway. Clear the roadway
- Pay attention to cables, ladders and workshop hoists that cross the roadway. Remove these obstacles
- Pay attention to half-open roll-up doors as the safety laser scanner cannot detect half-open roll-up doors.

For collision avoidance, the roadways must be level and free of obstacles in order for the safety laser scanner to be able to detect the working environment correctly.

- Before moving the truck, check the roadway for any obstacles. Clear the roadway

## Collision avoidance of the iGo neo

Pay particular attention to objects in the roadway that extend more than approx. 9 cm in height above the ground, e.g. long objects that protrude out of the rack. The safety laser scanner detects only the area close to the ground. On trucks with a collision avoidance camera (variant), this area is recorded and monitored as well.

### Minimum distance to obstacles in the roadway

Pallets, containers and similar items must always be set down in such a way that a safety distance of 50 cm is always maintained between the truck contour (including the load) and the obstacles.

If this safety distance is not maintained, the operating company must ensure that safety is guaranteed for persons and objects in another way.

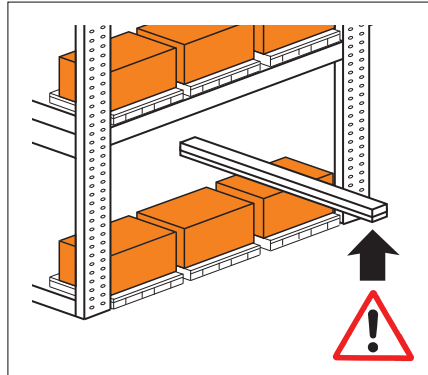

## Collision avoidance in "Assistance" mode

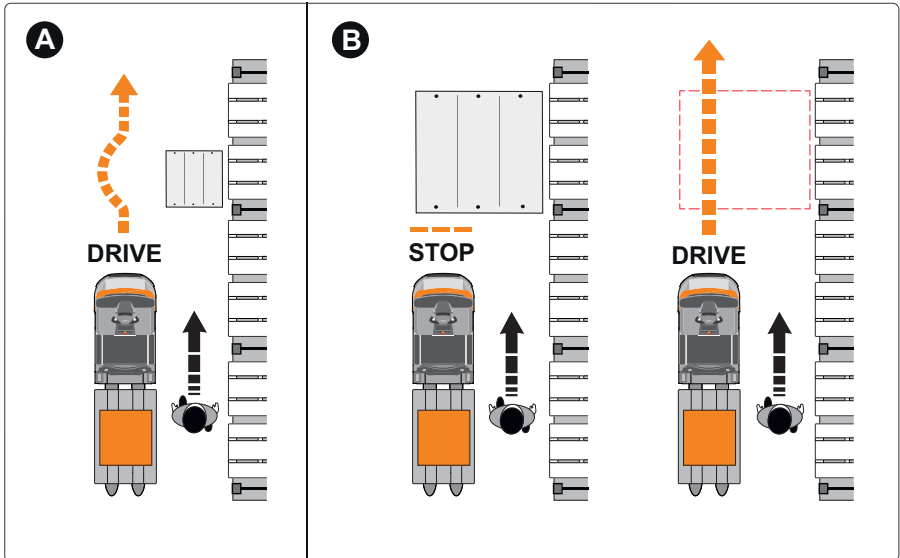
**⚠ DANGER****Danger due to collisions with obstacles that the safety laser scanner cannot detect.**

Observe the notes in the chapter entitled "Limits to the detection of obstacles".

- Make sure that the roadway is checked for obstacles that the safety laser scanner cannot detect. Remove these obstacles.
- If there is a risk of danger, immediately bring the truck to a standstill by pressing one of the emergency off switches.

If the truck detects an obstacle on the side of the roadway to which the truck is aligned, the truck automatically avoids the obstacle and continues on its path (A).

If an obstacle is too large to drive around, the truck stops in front of the obstacle (B). Assistance mode is resumed without intervention from the operator as soon as the obstacle is removed.

## Collision avoidance of the iGo neo

**Minimum distance to obstacles**

The authorised service centre can configure a minimum distance (1) at which the truck may pass an obstacle when in Assistance mode.

- Observe the notes in the chapter entitled "Required safety distances in the aisle".

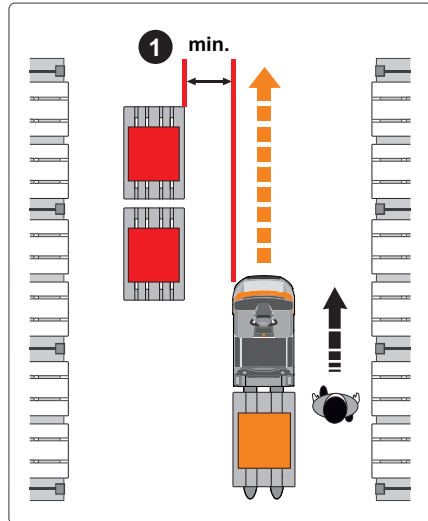

## "Easy Protect" collision avoidance (variant)

### ⚠ CAUTION

Limitations of assistance systems

"Easy Protect" collision avoidance is an assistance system. It supports the operator in avoiding collisions in manual drive mode. The operator must be aware of the limitations of this system. The operator must not rely exclusively on the system.

The operator remains responsible for handling the truck safely.

The "Easy Protect" assistance system is an addition to the collision avoidance system on the iGo neo. It supports the operator in avoiding collisions even in manual drive mode.

When the operator approaches an obstacle in the roadway, "Easy Protect" flexibly reduces the driving speed. "Easy Protect" takes into account the position of the obstacle, the driving speed and the current steering angle when cornering.

The operator can safely avoid the obstacle or stop in front of it in time. The truck does not brake to a standstill in front of the obstacle.

"Easy Protect" does not interfere with the steering of the truck.

Trucks with "Easy Protect" collision avoidance are marked with an information sign. ▷

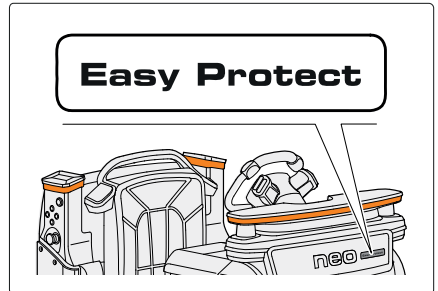

## Collision avoidance of the iGo neo

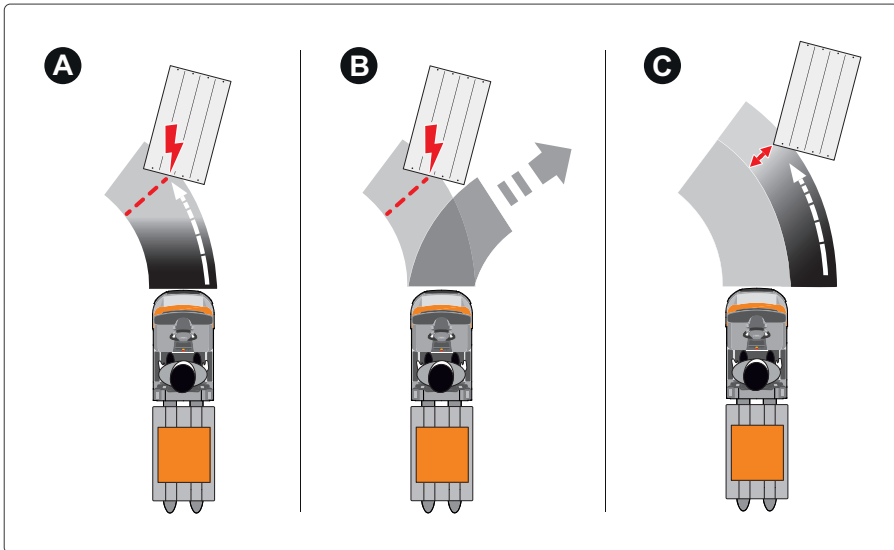

"Easy Protect" flexibly adjusts the driving speed to support the operator in their driving situation:

- A When approaching an obstacle, the truck brakes softly. The operator can avoid the obstacle in a safe and controlled manner. The truck does not brake to a standstill.
- B During the brake intervention, the truck detects that the operator is steering around the obstacle. The brake intervention ends and the driving speed is enabled.
- C When approaching an obstacle, the truck proactively checks the distance at which the obstacle is passed. The truck adjusts its speed according to the distance. In doing so, "Easy Protect" brakes more strongly in curves than when driving straight ahead.

The speed limitation is lifted as soon as the obstacle is no longer in the field of vision of the safety laser scanner.

## Driving safety regulations with "Easy Protect"

The limits of the safety laser scanner in detecting obstacles also apply to "Easy Protect" collision avoidance. Observe the notes in the chapter entitled "Limits to the detection of obstacles".



The safety laser scanner detects obstacles at a scanning height of 9 cm. "Easy Protect" may react too late to trucks, trolleys and objects with overhang (1). In manual drive mode with "Easy Protect", the operator must brake or avoid objects with an overhang in good time.

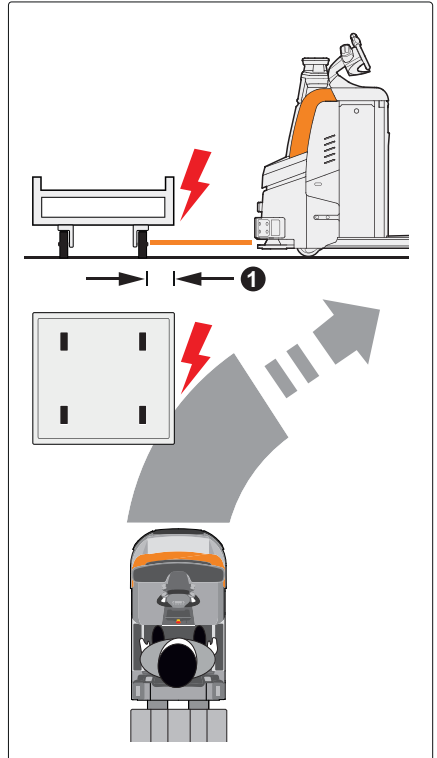

### CAUTION

Risk of accident if driving speed is too high

Even with "Easy Protect", the operator must avoid dangerous situations by driving carefully.

- Do not drive at high speed towards obstacles or people.
- Do not drive towards oncoming trucks.

### CAUTION

"Easy Protect" is ready for operation approx. 30 seconds after the truck is switched on.

The LED signalling units indicate when "Easy Protect" is ready for operation.

- Drive carefully until the initialisation is complete.

## Collision avoidance of the iGo neo

As soon as the operator drives backwards (in the load direction), the truck can collide with obstacles next to or behind the truck. "Easy Protect" only reacts to obstacles detected by the safety laser scanner in front of the truck.

- When steering when reversing, pay particular attention to obstacles next to the truck, as the truck swings out at the front.

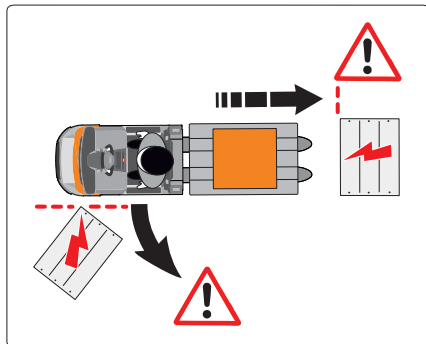

## Driving with "Easy Protect"

"Easy Protect" is ready for operation approx. 30 seconds after the truck is switched on. When the operator enters the driver's platform, the central part of the LED signalling unit lights up permanently.

### ⚠ CAUTION

"Easy Protect" does not brake the truck to a standstill in front of an obstacle

"Easy Protect" slows the truck down to creep speed. The operator has to stop or avoid the obstacle themselves.

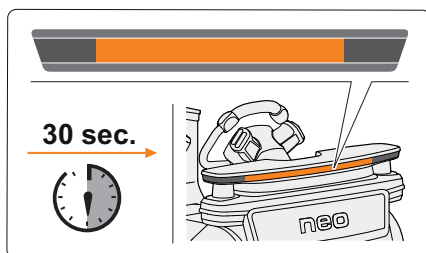

If no obstacles are detected in the roadway (1), "Easy Protect" does not intervene in drive mode.

When approaching an obstacle (2), "Easy Protect" flexibly reduces the driving speed. The truck brakes.

When approaching approx. 25 cm (3), the truck only travels at creep speed. The truck does not brake to a standstill in front of the obstacle. The operator must avoid the obstacle or stop.

When the obstacle is no longer in the field of vision of the safety laser scanner (4), "Easy Protect" enables the driving speed again.

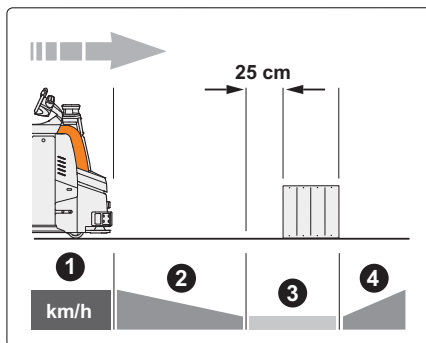



The LED signalling unit informs the operator about "Easy Protect".

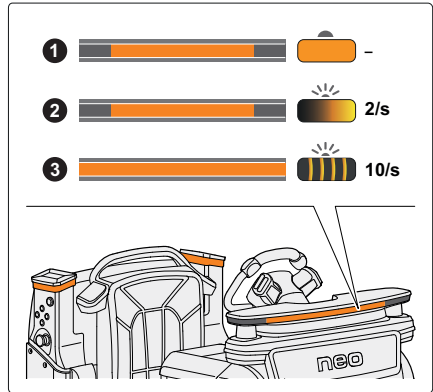

Display on the LED signalling unit

Signal	Truck function signalled
① Central part of the lighting zone remains permanently lit	"Easy Protect" ready for operation • No obstacle detected in the roadway
② Central part of the lighting zone flashes (approx. twice per second)	Brake intervention through "Easy Protect" • Truck approaching an obstacle
③ Light signal flashes rapidly (approx. 10 x per second)	Caution: distance between truck and obstacle not more than 25 cm • The operator must avoid the obstacle or stop

### Briefly interrupting "Easy Protect"

**⚠ CAUTION**

Risk of accident when interrupting "Easy Protect"  
The operator may only interrupt "Easy Protect" if objects or persons cannot be damaged.

In order to increase the flexibility of "Easy Protect" in certain driving situations, the operator can interrupt the speed limitation for a short time. This can be helpful, for example, if driving is restricted by a faulty or contaminated safety laser scanner.

The interruption is only possible if "Easy Protect" has already slowed down to almost creep speed in front of an obstacle.

- Move the accelerator to the zero position once and actuate it again immediately within one second. The truck accelerates slowly to the speed set by the operator.

## Collision avoidance of the iGo neo

The interruption of "Easy Protect" ends automatically as soon as the obstacle is no longer in the field of vision of the scanner. The truck returns to normal drive mode with "Easy Protect".

The interruption also ends when the operator leaves the driver's platform or the truck moves backwards (in the fork direction).

### Configuring "Easy Protect"

The authorised service sets the intensity level at which "Easy Protect" intervenes in drive mode. The settings are made in the service software.

The aim of the setting is to optimally support the working procedure of the operator.

#### Brake intervention intensity levels

1	Early intervention (earliest brake intervention in the event of obstacles)
2	STANDARD (normal brake intervention in the event of obstacles)
3	Late intervention (latest brake intervention in the event of obstacles)

In addition, the authorised service centre sets whether and with which buttons the operator can select the intensity level themselves.

#### Setting the selection options

- Fixed intensity level (no selection by the operator)
- Selection of the intensity level by the operator
  - Button assignment of the "Blue-Q" button
  - Button assignment of the "Tortoise" button
  - Standard specification (without actuating any of the buttons)



#### NOTE

*The iGo neo is prepared for the "Easy Protect" variant ex works. Contact the authorised service centre to use "Easy Protect" permanently or for trial purposes.*

## Operating the truck in "Assistance" mode

### Overview of "Assistance" mode

#### CAUTION

Risk of accident as a result of differences between the Manual and Assistance modes of operation.

In Manual mode, the safety devices that are available in Assistance mode do not assist the driver. The truck does not brake automatically or steer automatically.

- For "Easy Protect" collision avoidance (variant), observe the operating information.
- Pay full attention when operating the truck, taking safety into account at all times.

The operator can switch between the Manual and Assistance modes of operation:

- Manual mode corresponds to the operation of the OPX series-production truck
- Assistance mode is the additional mode of operation of the iGo neo

### "Assistance" mode

Assistance mode supports the operator when picking items from the rack or placing them into the rack. The truck detects the position of the operator and the contour of the warehouse aisle. During order picking, the truck independently follows the operator along this contour. This enables the operator to load and unload the truck without interruption.

Whenever the operator is standing on the driver's platform of the truck, the truck is in Manual mode.

As soon as the operator leaves the driver's platform, the truck switches to Assistance mode.

Assistance mode can be ACTIVE or PAUSED.

- In ACTIVE mode, the truck follows the operator automatically (movement tracking)
- In PAUSED mode, the truck remains stationary or stops

The operator switches between the ACTIVE and PAUSED statuses using the remote control or the assistance button on the truck. The

## Operating the truck in "Assistance" mode

operator can control other truck functions using the remote control (e.g. lifting and lowering).

In Assistance mode, the truck moves only in the drive direction, not in the load direction. During this process, the truck maintains a safety distance (1) to the rack in which the operator can move safely. This safety distance is always set to at least 50 cm. Further safety distances (e.g. from obstacles in the roadway) are set by the authorised service centre.

The truck automatically drives around obstacles in the roadway, provided that safety distances and the size of the obstacle allow for this. If it is not possible to avoid an obstacle, the truck will stop in front of the obstacle.

The safety laser scanner monitors the roadway. The safety laser scanner stops the truck in the event of danger to persons or resulting from obstacles.

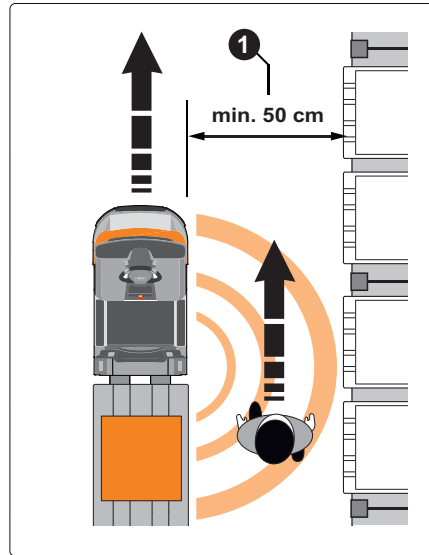

## Switching the truck on and off

### Switching on the truck

- Switch on the truck following the instructions given in the original operating instructions for the series-production truck.

The components for Assistance mode are initialised. The components are ready to operate after approximately 30 seconds.

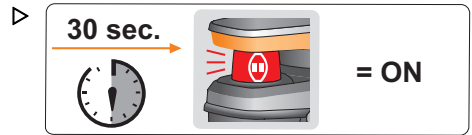

#### NOTE

*After the LED signalling units flash (after approx. 20 seconds), the truck is ready to be operated in Manual mode.*

### Switching off the truck

- Switch off the truck following the instructions given in the original operating instructions for the series-production truck. The truck is switched off.

#### NOTE

*The robotics system does not switch off automatically until the selected run-on time has elapsed. The authorised service centre can configure the run-on time to a period between 30 seconds and 60 minutes.*

## Operating the truck in "Assistance" mode

### Switching on "Assistance" mode

Before Assistance mode is available, the remote control must be connected and Assistance mode must be switched on.

### Connecting the remote control to the truck

When commencing Assistance mode, the operator must connect the remote control to the truck once.

The truck only ever executes the inputs of the remote control currently connected.

- To connect the remote control, enter the driver's platform and press the iGo neo button (1) on the remote control.

The remote control confirms successful registration by flashing the display LEDs for 5 seconds, and by a vibration signal.

If the connection is successful, the LED signalling units show the truck alignment in the aisle (LEFT - MIDDLE - RIGHT). The authorised service centre can configure the preferred initial truck alignment. If the connection fails, Assistance mode is disabled.

- While operating the truck, keep the remote control in the supplied holder at all times to ensure that the remote control cannot be damaged or actuated unintentionally.



### Switching on "Assistance" mode

- If necessary, the desired truck alignment can be adjusted using the remote control (see the following chapter "Adjusting the truck alignment").
- Press the iGo neo button on the remote control or on the truck.

Assistance mode is ACTIVE immediately. The truck follows the operator along the rack contour.

In the event of a dangerous situation, the operator can bring the truck to an immediate standstill at any time with the emergency off switches.

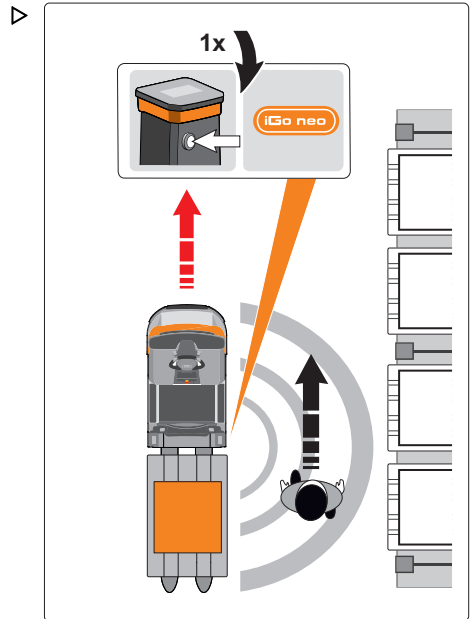

## Operating the truck in "Assistance" mode

### Adjusting the truck alignment ▷

Before order picking starts, the operator specifies whether the truck must align to the right (1), in the middle of the aisle (2) or to the left of the aisle (3). In Assistance mode, the truck then automatically follows the selected rack contour.

– Adjust the truck alignment using the remote control:

Button (A)

- Push x 1 briefly: Switch the truck alignment in sequence (LEFT ► MIDDLE ► RIGHT ► LEFT ...)

The LED signalling units signal the set truck alignment:

- Truck alignment RIGHT (1)
- Truck alignment MIDDLE (2)
- Truck alignment LEFT (3)

The truck emits a short signal tone to confirm the selection of the truck alignment. If the truck does not detect the rack contour on the side of the roadway to which the truck is aligned, the truck position must be corrected manually.

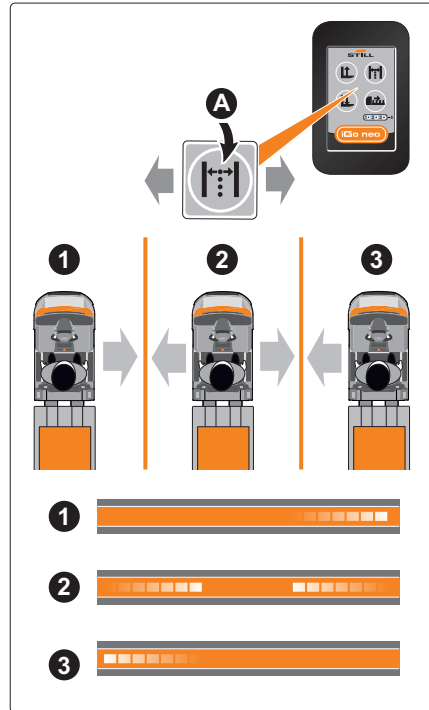



## Positioning the truck correctly in the aisle ▷

### Positioning the truck in the aisle

It must be possible for the truck to detect a straight rack contour.

The rack contour (distance between the rack uprights) must not have any gaps larger than 2.7 m (can be parameterised). Larger gaps are detected as a crosswise roadway.

It must be possible for the truck to detect the rack contour (1) over a distance of 2 to 3 m in front of the truck.

The truck must be positioned parallel to the rack.

### Specifying the distance to the rack contour

The truck retains the distance to the rack contour that it had when switched to Assistance mode ACTIVE. This distance is set when the operator leaves the driver's platform.

- Drive the truck manually to the starting point for Assistance mode.
- Position the truck at the required distance parallel to the rack. The selected distance (2) must be between 50 cm and 250 cm. If an insufficient distance is specified, the truck will steer until a distance of 50 cm (or a larger fixed distance) is reached.
- Leave the driver's platform. If necessary, switch to Assistance mode ACTIVE.

The truck follows the rack contour at the specified distance.

### NOTE

*The authorised service centre can configure a permanent distance to the rack contour.*

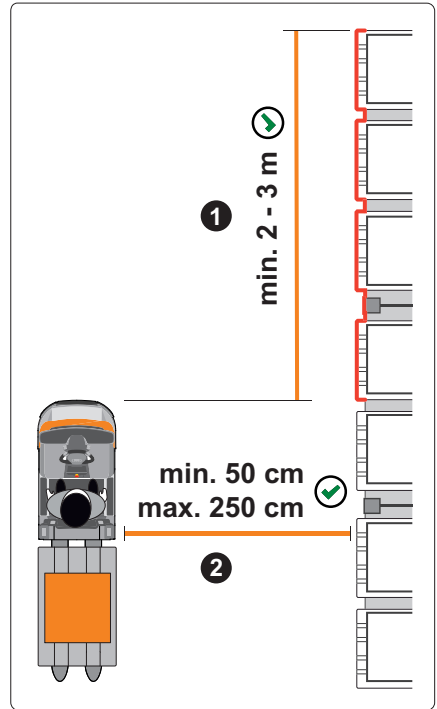

## Operating the truck in "Assistance" mode

### Correctly positioning the truck in line with the rack when the truck is aligned sideways

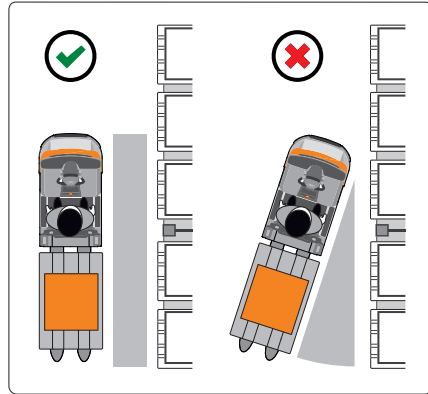

#### ⚠ CAUTION

Risk of collision if the truck is positioned at too sharp an angle in relation to the rack contour

If the truck is positioned at too sharp an angle in relation to the rack contour, the system may not correctly detect the rack under certain circumstances and will therefore collide with the rack.

- Before commencing Assistance mode, always position the truck parallel to the rack.
  - Slowly set the truck in motion. Bring the truck to an immediate standstill if the safety distance of 50 cm to the rack is not reached.
- 
- Drive the truck in Manual mode to the starting point for Assistance mode.
  - Position the truck parallel to the rack at the desired distance (min. 50 cm).

### Correctly positioning the truck in the centre of the aisle

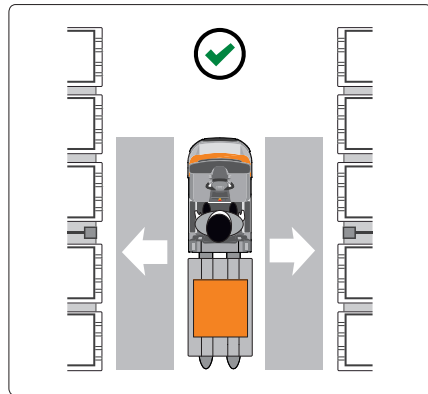

- Drive the truck in Manual mode to the starting point for Assistance mode.
- Position the truck parallel to the rack so that it is in the centre between the two racks.

### Switching between ACTIVE and PAUSED states for "Assistance" mode

Using the iGo neo button on the remote control or on the truck, the operator can switch between the ACTIVE and PAUSED states for Assistance mode.

- Before entering the truck, always switch Assistance mode to PAUSED. Allow the truck to come to a standstill. The LED displays of the movement tracking sensors must display the symbol (🚫).

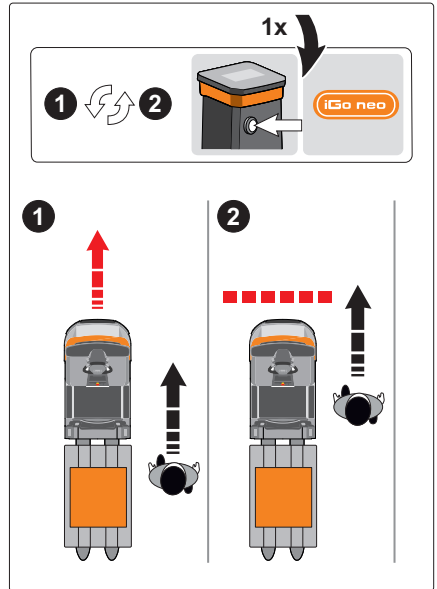

iGo neo button	Assistance mode		
Push 1 x briefly	When the truck is stationary:		
	PAUSED	→	ACTIVE
1 x long press (min. ½ sec.)	When the truck is in motion:		
	ACTIVE	→	PAUSED
1 x long press (min. ½ sec.)	When the truck is stationary:		
	ACTIVE	→	PAUSED

### Start-up signals of iGo neo

After a standstill of between two seconds and ten seconds	One short remote control pulse
After a standstill of more than ten seconds	One short remote control pulse plus warning sound
After an emergency stop or Assistance mode is switched to PAUSE	One short remote control pulse plus warning sound

## Operating the truck in "Assistance" mode

### Independently switch back from "Assistance" mode to "PAUSE"

- After an emergency stop via an emergency off switch
- After prolonged actuation (more than three seconds) of a truck button (e.g. lift/lower fork carriage buttons)
- If the operator is absent for longer than 30 seconds (remote control out of range)

## Identifying the operator

For the movement tracking to work, the truck must identify the operator. This is necessary when you start Assistance mode or if the truck has lost the position of the operator.

Identification as operator in Assistance mode
• Automatically when the operator steps off the driver's platform
• Press the assistance button on the remote control or on the truck

- Always pay attention to the LED signals of the movement tracking sensors to check whether Assistance mode is ACTIVE and focussed on the operator.

## Operating the truck in "Assistance" mode

### Stopping automatically at the end of the racking or in a cross-wise roadway

#### **⚠ CAUTION**

Risk of collision at the end of the racking or when entering the crosswise roadway

If an object, e.g. another truck, is stationary in an unfavourable position at the end of a rack or in a crosswise roadway, the truck may not detect the end of the rack under certain circumstances. Crossing trucks could then collide with the truck that is operating in *Assistance* mode.

- The operator must be particularly alert at the end of a rack. When the truck is in *Assistance* mode, the operator must ensure that the truck does not drive beyond the end of the rack. The operator is responsible for stopping the truck safely.

The truck is equipped with automatic end-of-rack detection. If the racking on the side to which the truck is aligned ends or if the racking is interrupted by a crosswise roadway, the truck will stop automatically.

### Stopping at the end of the racking

The truck detects that the rack contour does not continue and the truck stops automatically at the end of the aisle. The LED display of the movement tracking sensors (1) changes to "Assistance mode PAUSED".

- To continue in *Assistance* mode, drive the truck to a detectable rack contour in *Manual* mode.

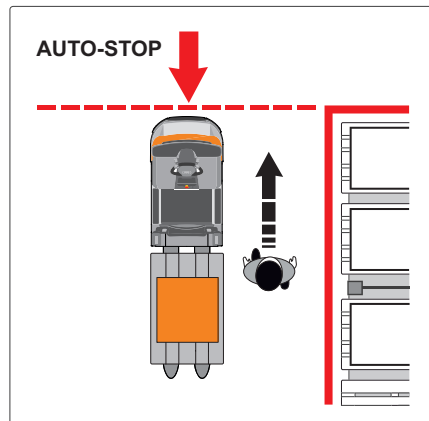

### Stopping before a crosswise roadway

The truck can cross a crosswise roadway in Assistance mode. The operator must first press the iGo neo button on the remote control or on the truck to enable the truck to proceed across the crosswise roadway.

The truck detects that the rack contour continues after the crosswise roadway. The truck stops automatically before the crosswise roadway. The LED display of the movement tracking sensors (1) changes to "Assistance mode PAUSED".

- Make sure that the truck can cross the crosswise roadway safely.
- Briefly press the iGo neo button on the remote control or on the truck once. The LED display of the movement tracking sensors changes to "Assistance mode ACTIVE". The truck follows the operator over the crosswise roadway.

If the truck fails to detect a continuation of the rack contour beyond the crosswise roadway, the truck will not move off. The truck must then be driven to a detectable rack contour in Manual mode.

#### NOTE

*The authorised service centre can configure the value for the minimum width of crosswise roadways. This improves the detection of crosswise roadways.*

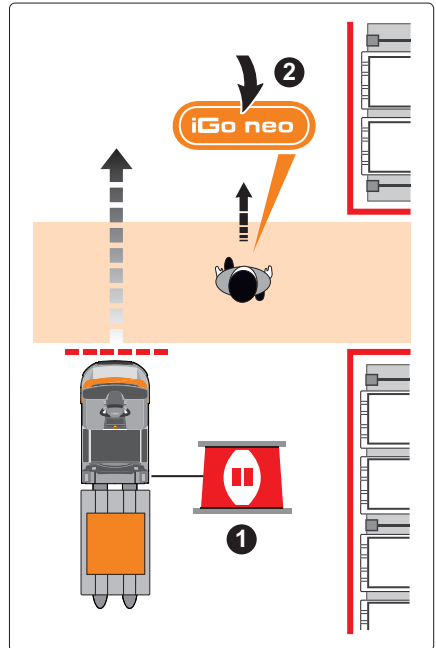

## Operating the truck in "Assistance" mode

### Truck behaviour in the event of an emergency stop ▷

If an emergency off switch is pushed or the safety laser scanner detects a sudden hazard, the truck reacts with an emergency stop.

- The electromagnetic truck brake is applied. The truck stops at the maximum deceleration rate
- The LED signalling unit shows the "Emergency stop" signal. The lighting zones flash in rapid alternation (approx. ten times per second)
- The truck emits the audible warning sound to indicate the "emergency stop" (short, rhythmic warning sounds)



### Emergency stop via the safety laser scanner

#### ⚠ CAUTION

Risk of accident when the truck starts moving again after an emergency stop.

After an emergency stop, *Assistance* mode becomes *ACTIVE* again as soon as the roadway is clear.

- Maintain a safety distance if the truck starts to move again automatically after an emergency stop.

If an obstacle appears suddenly in front of the truck or approaches the truck, the safety laser scanner detects a critical situation. The truck will automatically perform an emergency stop to prevent a collision.

*Assistance* mode is resumed without intervention from the operator as soon as the obstacle is removed.

Setting off after an emergency stop via the safety laser scanner:

- The electromagnetic truck brake is released
- The LED signalling unit stops showing the "Emergency stop" signal and changes back to the previous display. The truck stops emitting the audible warning sound to indicate the "emergency stop"
- If *Assistance* mode is *ACTIVE*, the truck emits a warning sound prior to setting off. The warning sound is output only if the



truck has been stationary for at least 10 seconds

- Pay attention to the "Assistance mode ACTIVE" LED signal of the movement tracking sensors and to the warning sound.

### Emergency stop via an emergency off switch

By pushing an emergency off switch, the operator brings the truck to an immediate standstill in the event of a dangerous situation.

After an emergency stop via an emergency off switch on the side of the truck, the truck switches to Assistance mode PAUSED.

- Release the emergency off switch (1) before recommencing operation.

Setting off after an emergency stop via an emergency off switch:

- The electromagnetic truck brake is released
- The LED signalling unit stops showing the "Emergency stop" signal and changes back to the previous display The truck stops emitting the audible warning sound to indicate the "emergency stop"
- Assistance mode only becomes ACTIVE when the operator presses the iGo neo button on the remote control or on the truck
- Pay attention to the "Assistance mode PAUSED" LED signal of the movement tracking sensors.

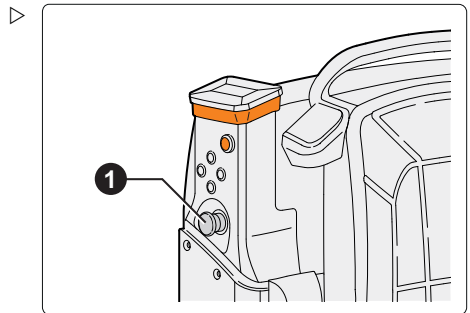

### Emergency stop via the emergency brake push button in the cockpit

If the emergency stop has been triggered via the emergency brake push button (1) in the cockpit, the truck stops immediately.

After the truck has come to a standstill, Assistance mode continues without the intervention of the operator.

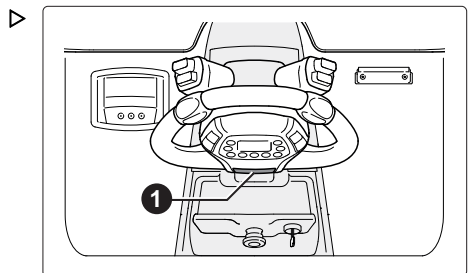

## Operating the truck in "Assistance" mode

Setting off after an emergency stop via the emergency brake push button in the cockpit:

- If Assistance mode is ACTIVE, the truck emits two brief warning sounds prior to setting off. The warning sound is output only if the truck has been stationary for at least 10 seconds
- Pay attention to the "Assistance mode ACTIVE" LED signal of the movement tracking sensors.

## Moving the stop position next to the operator to the next pallet

Trucks with long forks can transport several pallets one behind the other. The remote control can be used to move the truck stop position next to the operator so that the required pallet is always within range.

The authorised service centre can configure a maximum of four different stop positions.

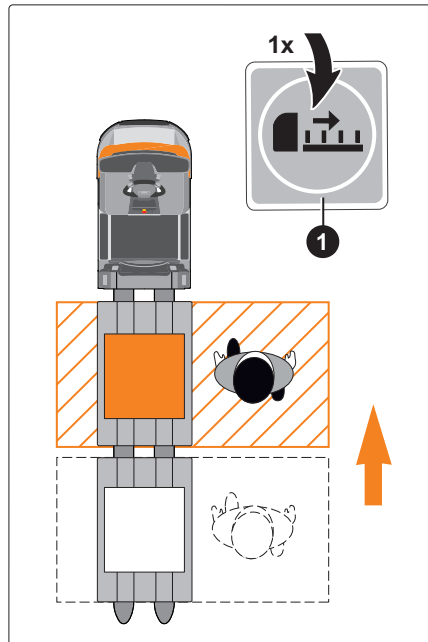

The LED display on the remote control (2) shows the position currently selected "1-2-3". If all of the LEDs are lit, position "4" is selected.

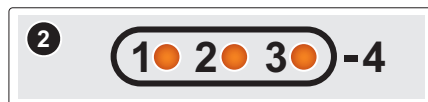

## Moving the stop position via the remote control

- Briefly push the button (1) once on the remote control. The selected stop position moves along one position in the direction of

the load side. If position "4" is reached, the selection begins again at position "1".

### Moving the stop position using the keypad on the side of the truck ▷

- Push button (1). The selected stop position moves along one position in the direction of the drive side. When the end position "1" is reached, the truck emits two short beeps.
- Push button (2). The selected truck position moves along one position in the directions of the load side. When the end position "4" is reached, the truck emits two short beeps.

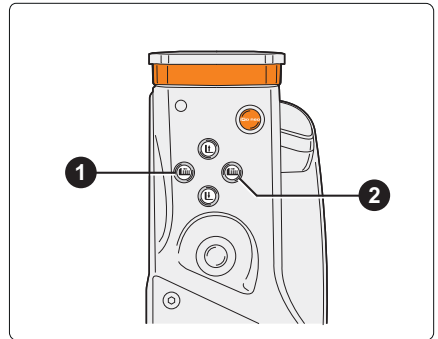

## Operating the truck in "Assistance" mode

## Driving automatically without movement tracking ▷

The operator can allow the truck to drive a short distance along the rack contour independently of the movement tracking.

- The LED displays of the movement tracking sensors must display "Assistance mode PAUSED" (1).
- Press and hold the iGo neo button on the remote control for at least two seconds. The LED signal for the movement tracking sensors changes to "operator not identified".

The truck moves along the rack contour until the button is released. The truck safety functions remain active.

- If necessary, perform operator identification again on the truck.

If the truck fails to detect a rack contour it does not set off or stops. The movement tracking sensors will show the "PAUSED" LED signal.

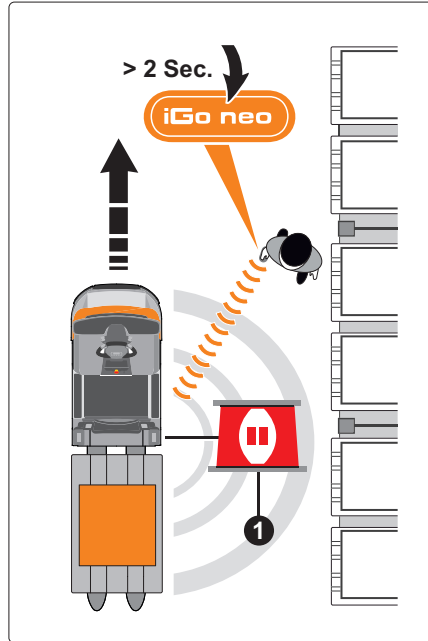

### NOTE

*The authorised service centre can deactivate the "Driving automatically without movement tracking" function on request.*

## Lifting and lowering the fork carriage ▷

In Assistance mode, the operator controls the lifting functions via the remote control or by using the keypad on the side of the truck.

Lifting or lowering starts with a short delay, accompanied by a signal tone. An increase in the frequency of the signal tone warns the operator to keep his feet away from the area under the forks.

The OPX-L 20 S can approach six fixed lift heights. The authorised service centre can adjust the intermediate lift heights and the end lift height to meet customer-specific requirements (from 01/2021 onwards).

### ⚠ WARNING

Risk of feet being crushed when lowering

- Keep feet away from the area under the forks.
- Pay attention to the increase in the frequency of the signal tone.

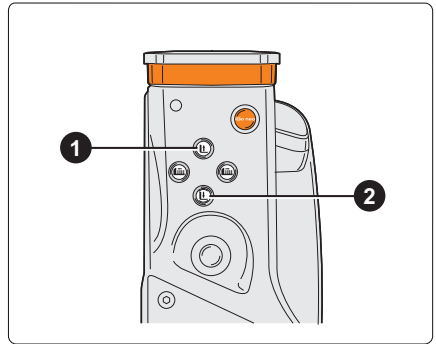
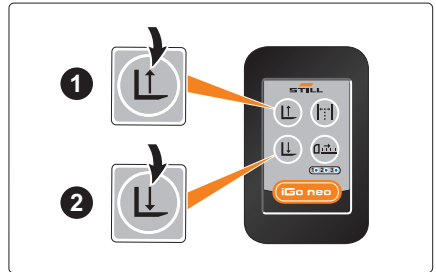

Truck type	Button ① (lift)	Button ② (lower)
OPX 20/25 (initial lift)	<ul style="list-style-type: none"> <li>• Hold the button down: The fork carriage comes to a stop when the button is released</li> <li>• Briefly push the button: The fork carriage stops after 1 sec.</li> </ul>	<ul style="list-style-type: none"> <li>• Hold the button down: The fork carriage comes to a stop when the button is released</li> </ul>
OPX-L 12 (main lift) <sup>(1)</sup> OPX-L 20 (main lift) <sup>(1)</sup>	<ul style="list-style-type: none"> <li>• Hold the button down: The fork carriage comes to a stop when the button is released</li> <li>• Briefly push the button: The fork carriage stops after 1 sec.</li> </ul>	
OPX-L 20 S (main lift) <sup>(1)</sup>	<ul style="list-style-type: none"> <li>• Long press the button (min. ½ sec.): Fork carriage moves to the upper/lower end position</li> <li>• Briefly push the button: Fork carriage comes to a stop at the next defined lift height</li> </ul>	

<sup>(1)</sup> On trucks with a main lift, the lowering procedure automatically stops at 300 mm.

- To lower the fork carriage further, push and hold the "Lower" button again
- The fork carriage comes to a stop when the button is released
- In the OPX series-production truck, the initial lift is controlled in the truck cockpit

## Operating the truck in "Assistance" mode

### **Cancelling the lifting operation or lowering procedure**

- Press the button for lifting or lowering again or press it and hold it. The lifting operation or lowering procedure stops immediately.

## "Z picking" mode

"Z picking" mode assists the operator in allowing frequent changes between the right and left side of the racking.

If the operator pushes the right-hand or left-hand iGo neo button on the truck, the alignment of the truck changes to the corresponding side. The truck now aligns itself with the rack contour on the selected side.

The distance (X) from the rack contour cannot be changed. The fixed value for the distance is configured by the authorised service centre, depending on the application conditions. The minimum distance that can be set is 50 cm.

"Z picking" mode must be set up and permanently enabled by an authorised service centre. The operator cannot switch between standard mode in which the distance can be changed and "Z picking" mode.

### Operating the truck in "Z picking" mode

- Press the iGo neo button (1) on the required picked side.

The truck then follows the operator at a fixed distance from the rack contour on the selected side. The truck then steers automatically until the specified distance is reached (2).

The truck alignment can be redefined at any time using the remote control.

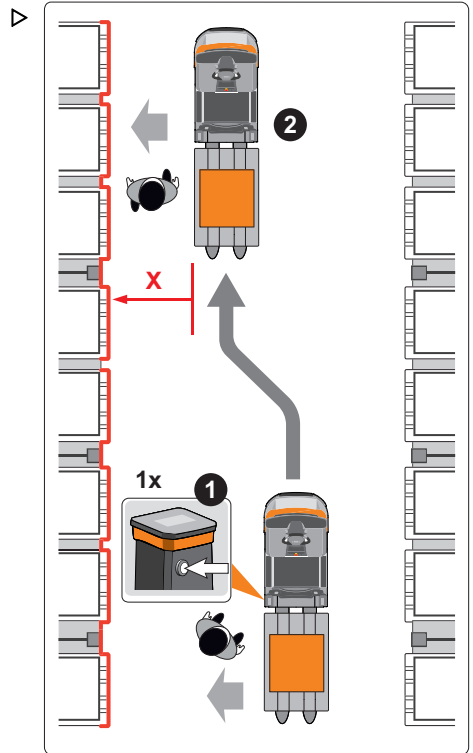

## Operating the truck in "Assistance" mode

### Setting the drive programme when operating in "Assistance" mode

In Assistance mode, the operator can select between two drive programmes (standard / tortoise). By selecting the drive programme, the operator can adjust the driving characteristics of the truck (driving dynamics, steering dynamics, braking dynamics) to suit the application situation. All safety-related features of the truck remain unchanged.

- Push the "tortoise" button to toggle between the drive programmes. The current drive programme is indicated on the display-operating unit.

The authorised service centre can configure the drive programmes for Assistance mode to suit the specific requirements of the customer.



#### NOTE

*The "Tortoise" button can also be to select the intensity level the of "Easy Protect" collision avoidance system (variant).*

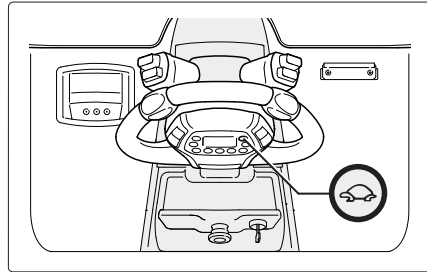



## Warning sounds in "Assistance" mode

The truck produces different warning sounds to alert the driver and bystanders that the truck is being operated in Assistance mode.

### Audible signals

Type of signal	Signal	Information
1 short warning sound	"Setting off" warning sound	Truck begins moving automatically (with Assistance mode ACTIVE). The warning sound is output only if the truck has been stationary for at least 10 seconds.
Short, rhythmic warning sounds	"Emergency stop" warning sound (safety laser scanner)	Truck has performed an emergency stop
	"Emergency stop" warning sound (emergency off switch)	The operator has pressed the emergency off switch
Brief warning sounds increasing in frequency	Lifting or lowering of the forks Increase in the frequency of the sound when lowering into the danger area for feet	Operator lifts or lowers the forks (using the remote control or the keypad on the side of the truck)

## Operating the truck in "Assistance" mode

**5**

---

**Storage**

## Storing and shutting down the iGo neo

### Storing and shutting down the iGo neo

Driverless transport vehicles cannot be stored in an operational state. They must therefore be taken out of operation.

- To shut down the truck, contact the authorised service centre.

**6**

---

## **Cleaning**

## Cleaning the components used for "Assistance" mode

### Cleaning the components used for "Assistance" mode

#### ⚠ CAUTION

If water penetrates the electrical system, there is a risk of a short circuit occurring!

- Never clean the components used for Assistance mode using devices such as high-pressure cleaners or rotating brushes.
- While cleaning the rest of the truck, avoid cleaning the components used for Assistance mode and only clean these components in accordance with the instructions specified below.

#### ⚠ CAUTION

Risk from damage to electrical components when cleaning!

Only the authorised service centre is permitted to clean the components used for Assistance mode inside the truck.

- Contact the authorised service centre.

#### ⚠ CAUTION

Risk of component damage!

If the battery male connector is disconnected while the truck is switched on (under load), an arc will be produced. This can lead to erosion at the contacts, which considerably shortens the service life of the contacts.

- Switch off the truck before the battery male connector is disconnected.
- Do not disconnect the battery male connector while the truck is switched on, except in an emergency.

### Preparing the components used for "Assistance" mode for cleaning

Before cleaning, ensure that the truck cannot move.

- Park the truck securely on a level surface.
- Disconnect the battery male connector.
- Actuate the emergency off switch.
- Contact the authorised service centre to arrange for the components used for Assistance mode **inside** the truck to be cleaned.

### Cleaning the optics covers (movement tracking sensors, safety laser scanner, foot protection sensors) ▷

#### ⚠ CAUTION

Abrasive cleaning materials can damage the surfaces of components!

Using abrasive cleaning materials that are unsuitable for plastics can cause plastic parts to dissolve or become brittle. The covers of optical sensors can become cloudy.

- Do not use aggressive cleaning materials.
  - Do not use any abrasive cleaning materials.
- 
- Clean the optics covers (inspection windows) on the movement tracking sensors (1), on the safety laser scanner (2) and on the foot protection sensors (3) regularly and in the event of contamination. The foot protection sensors are installed only on variants with a pantograph lift.
  - A static charge causes dust particles to accumulate on the optics cover. To clean the optics cover, use the cleaning material listed in the table.

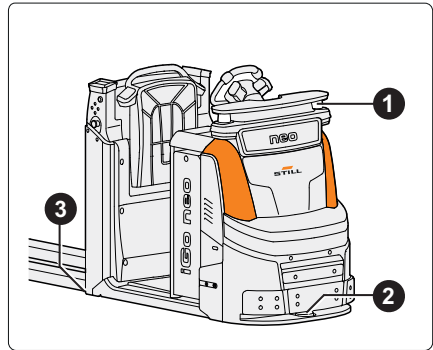

#### Recommended cleaning material for the optics covers

Cleaning material	SICK item number	STILL order number
Antistatic plastic cleaning agent	5600006	7302000907
SICK cleaning cloth	4003353	50103612103

- Remove any dust from the optics covers using a clean, soft brush.
- Moisten the SICK optics cloth with the anti-static plastic cleaning agent. Use the damp cloth to wipe the light output window on the optics covers.

### Cleaning other components used for "Assistance" mode

- Regularly clean the LED signalling unit using a soft, damp cloth without cleaning agents.
- Clean the remote control using a brush and a damp cloth. Do not use alcohol, solvents or cleaning materials.

## Cleaning the components used for "Assistance" mode

### Additional cleaning when alternating between different temperature ranges

#### CAUTION

Danger from the optical safety systems fogging up when moving between warm areas and cold areas

During use, ensure that the optics covers (inspection windows) on the movement tracking sensors, on the safety laser scanner and on the foot protection sensors do not fog up.

If the optics cover of the safety laser scanner fogs up, the truck may respond by initiating an emergency stop.

- Clean any fogged-up optics covers before starting operation in Assistance mode (see the chapter entitled "Cleaning").



7

---

Transport

## Transporting the truck

### Transporting the truck

The instructions in the operating instructions for the series-production truck apply for transporting the truck. In addition, the following provisions listed in this chapter also apply.

#### **⚠ CAUTION**

Risk of accident when using *Assistance mode* for loading purposes

When operating in *Assistance mode*, the truck can respond with involuntary steering and driving movements when used in an unsuitable environment.

- Routes to a loading point, on a loading bridge or on the transport vehicle must always be navigated in *Manual mode*.

### Crane loading of the truck not permitted

#### **⚠ CAUTION**

Risk of damage to the truck by impermissible crane loading

The mounting bracket for the LED signalling unit or the safety laser scanner can be damaged when loading by crane. Loading of the truck by crane is not permitted.

### Safety regulations for lashing down the truck

#### **⚠ DANGER**

#### **Risk of accident if the lashing straps slip!**

The truck must be lashed securely so that it cannot move during transportation.

- Make sure that the lashing straps are tightened securely and that the pads cannot slip off.

#### **⚠ CAUTION**

Risk of damage to the truck due to improper lashing

The mounting bracket for the LED signalling unit or the safety laser scanner can be damaged by lashing straps.

- Do not attach lashing straps to the LED signalling unit or the safety laser scanner or guide lashing straps over these components.

**⚠ CAUTION**

Abrasive lashing straps can rub against the surface of the truck and cause damage.

- Position slip-resistant pads underneath the lifting points (such as rubber mats or foam).

**Safety regulations for driving on loading bridges and ramps** ▷**⚠ DANGER****Risk of accident from the truck falling off the loading bridge**

Steering movements can cause the truck to fall from the loading bridge.

- Before driving across a loading bridge, ensure that the loading bridge is properly attached and secured.
- Ensure that the transport vehicle onto which the truck is to be driven has been sufficiently secured to prevent it from moving.
- Maintain a safety distance from other loading bridges, ramps, working platforms and similar objects.
- Drive slowly and carefully onto the transport vehicle.

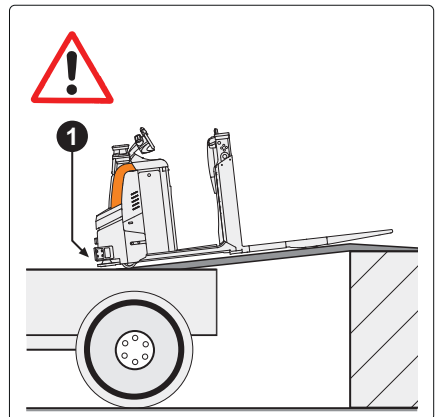
**⚠ CAUTION**

Risk of damage to the protective guard (1) and the safety laser scanner on loading bridges and ramps.

In the transition to gradients or slopes, the protective guard with the safety laser scanner can come into contact with the ground at the front of the truck. The safety laser scanner can be damaged as a result.

- Do not drive on gradients and slopes unless the ground clearance permits this without damage to any component.

## Transporting the truck

### CAUTION

Danger due to excessive transport weight on the loading bridge

The load capacity of the means of transport, the ramps and the loading bridges must be greater than the actual total weight of the truck. Components can be permanently deformed or damaged due to overloading.

- Determine the actual total weight from the nameplate on the truck.
- Only load the truck if the load capacity of the means of transport, ramps and loading bridges is greater than the total actual weight of the truck.

**8**

---

## **Maintenance**

## Maintaining the iGo neo

### Maintaining the iGo neo

This section contains all of the information required for maintaining the iGo neo. Maintenance must be performed in accordance with the points in the maintenance checklist. This is the only way guarantee that the truck remains ready for operation; it is also a pre-condition for any warranty claims.

#### Maintenance schedule

Maintenance tasks on the components for the Assistance mode of the iGo neo must be performed **in addition to the scheduled maintenance of the series-production truck**.

The intervals are defined for standard use. Shorter maintenance intervals can be defined in consultation with the operating company, depending on the application conditions of the truck.

The following factors may necessitate shorter maintenance intervals:

- Dirty, poor-quality roadways
- Dusty or salty air
- High levels of air humidity
- Extremely high or low ambient temperatures, or extreme changes in temperature
- Multi-shift operation with a high duty cycle
- National regulations for the truck or for individual components

#### Responsibility for maintenance

##### DANGER

**Work performed by unauthorised persons on components used for Assistance mode jeopardises the safety functions of the truck.**

To maintain components used for Assistance mode, contact the authorised service centre.

Maintenance work on components used for Assistance mode must only be performed by the service centre authorised by the manufacturer.

The service engineer must have received special training from the manufacturer regarding the handling processes, technology and repair work involved with the iGo neo. It is not

permitted for other persons to perform work on the components used for Assistance mode. This instruction does not apply to cleaning procedures on components that are not located inside the truck; refer to the chapter entitled "Cleaning".

The following components are used for Assistance mode:

- Safety laser scanners
- Movement tracking sensors
- Control components
- Control electronics and control software
- Emergency off switch
- LED signalling unit
- Switches
- Remote control (including reception components)
- Collision camera (variant)
- Foot protection sensors (variant)

### Safety regulations for maintenance

- Before starting any work on electrical and mechanical equipment, disconnect the system from the power supply. On the iGo neo, this is done by **disconnecting the battery male connector**.
- Secure and demarcate the working area. Use warning signs to indicate the increased level of danger.

### Maintenance documentation

The maintenance steps and results must be documented in writing and archived by the operating company.

## Maintenance - 1000 hours / yearly

## Maintenance - 1000 hours / yearly

At operating hours								Carried out			
1000		2000		3000		4000				5000	
6000		7000		8000		9000		10000			
11000										✓	✗
<b>Truck chassis</b>											
Visual inspection of the chassis extensions for wide load carriers (variant).											
<b>Safety laser scanner S300</b>											
Check the safety laser scanner and the support mounting for damage (visual inspection).											
Check the alignment and the field of vision of the SICK safety laser scanner using the SICK CDS software.											
Clean the optical cover of the safety laser scanner.											
<b>Movement tracking sensors</b>											
Check the movement tracking sensors and the mounting for damage (visual inspection).											
Check the plug contacts (power supply and communications supply).											
Check the status LEDs for the movement tracking sensors (visual inspection).											
Clean the movement tracking sensors.											
<b>LED signalling unit</b>											
Check the LED signalling unit and the support mounting for damage (visual inspection).											
<b>Components of the robotics system</b>											
Perform a visual inspection of the wiring and of the components (robotics computer, safety controller [MCU2], receiving unit for the remote control, switchbox, DC/DC converter, Digisound beeper, odometry signal transmitter, incremental transducer for revolution speed)											
Check the mechanical attachment of all components.											
Check that the screw contacts of the additional emergency off switches are securely fitted.											
Check that all screw contacts on the robotics computer are securely attached.											
Check that the earth cable between the chassis and the carrier plate is securely attached.											
<b>Robotics system</b>											



At operating hours										Carried out	
1000		2000		3000		4000		5000			
6000		7000		8000		9000		10000		✓	✘
11000											
Practical function checking of the robotics system when Assistance mode is active. Check the function of the safety laser scanner S300 and the movement tracking sensors, including the LED signals, foot protection sensors, LED signalling unit, assistance button, emergency off switch and remote control.											
Practical function checking of "Easy Protect" collision avoidance (variant) in Manual mode.											
<b>Personal protection system (MPSE)</b>											
Check the function of the personal protection system. Check the function of the emergency off switch and the safety laser scanner S300 in Assistance mode.											
Check the emergency off switching signal in "DiaMon".											
<b>General</b>											
Read out and check the error numbers and clear the list.											
Reset the maintenance interval.											

Maintenance - 1000 hours / yearly

## Technical data

## Dimensioni iGo neo OPX 20, 25

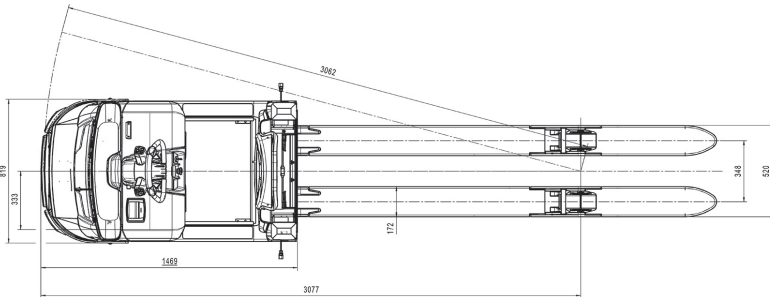
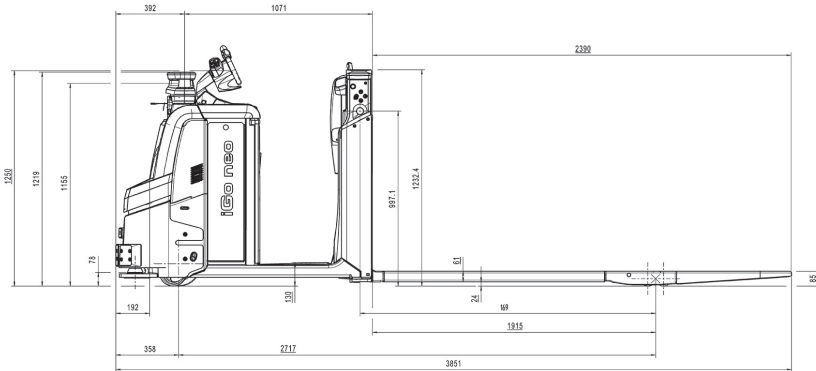
Dimensions  
iGo neo OPX 20, 25

# Dimensions iGo neo OPX-L 12

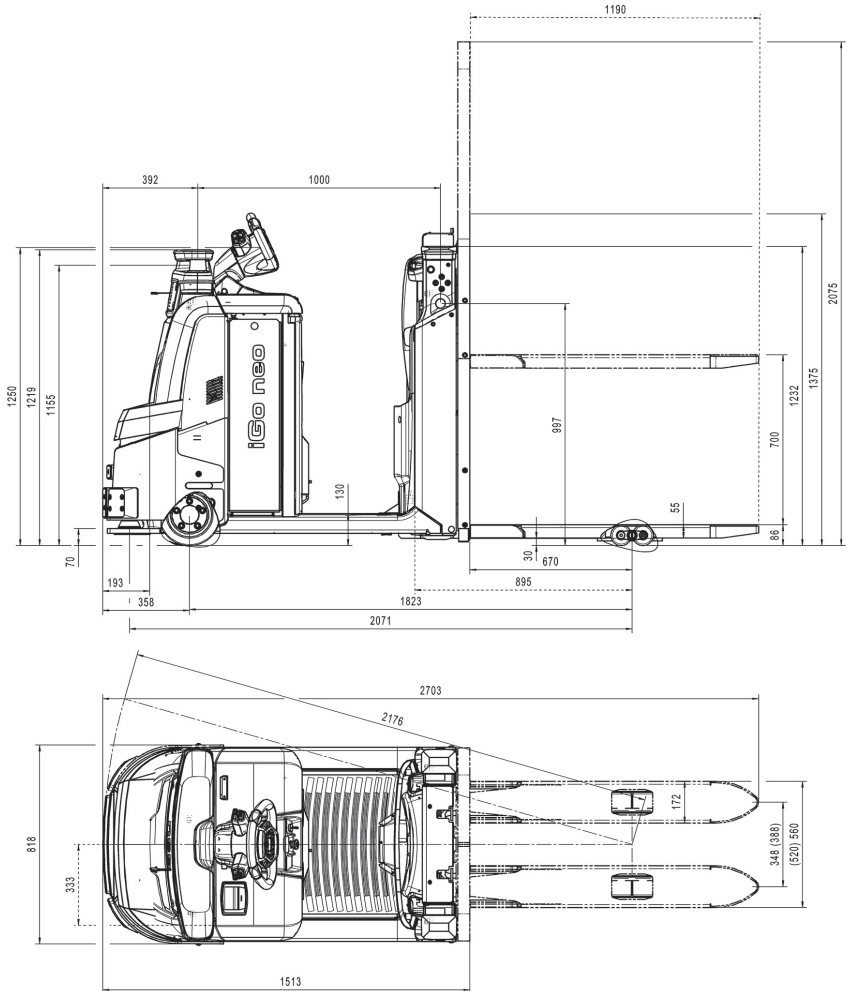

DimensioniGo neo OPX-L 20

Dimensions  
iGo neo OPX-L 20

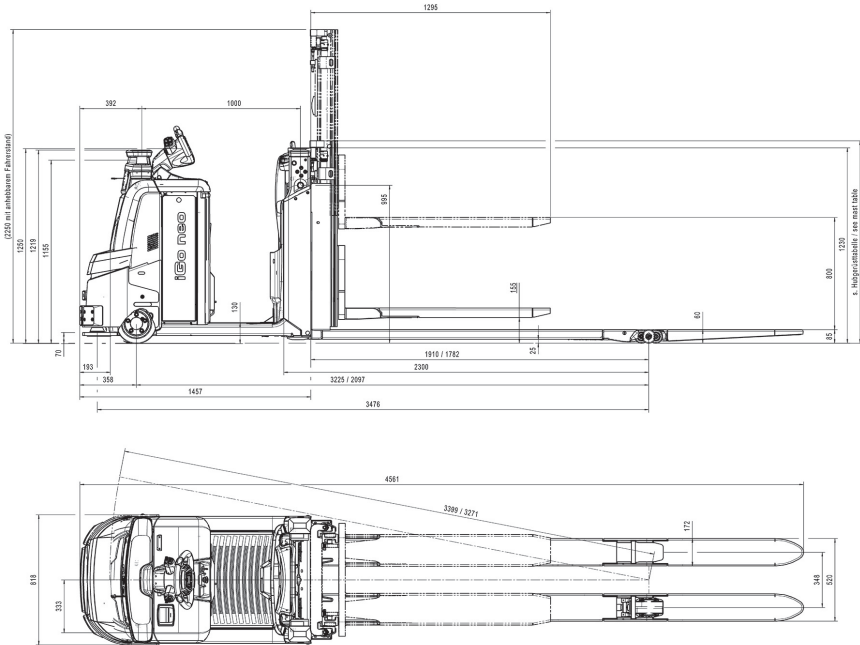

# Dimensions iGo neo OPX-L 20 S

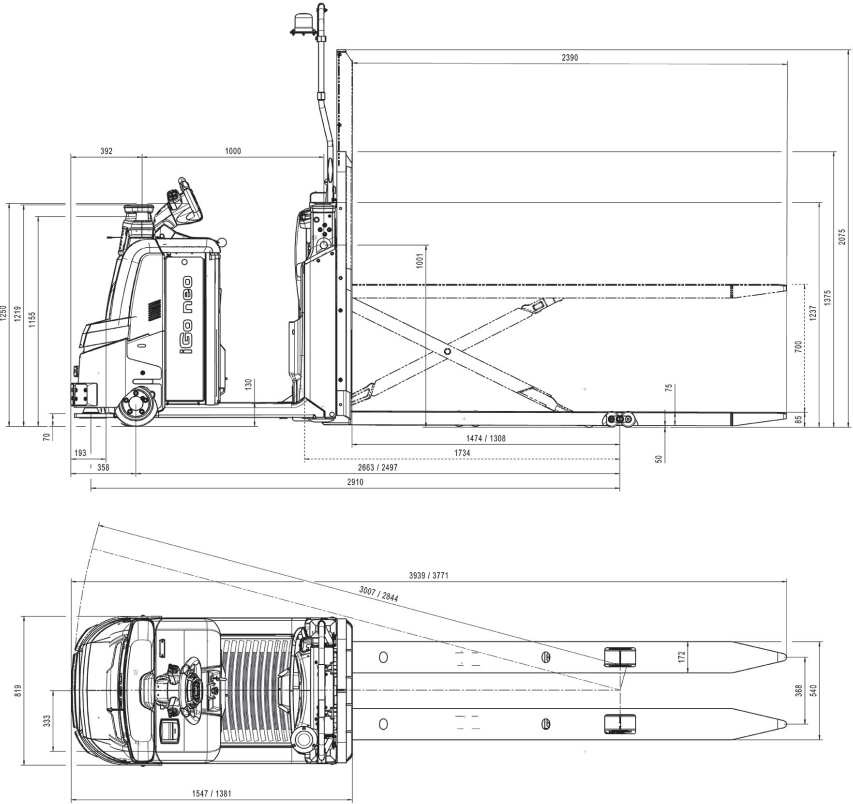

## VDI datasheet iGo neo OPX 20, 25

VDI datasheet  
iGo neo OPX 20, 25 NOTE

*This VDI datasheet specifies only the technical values for industrial trucks with standard equipment. Different tyres, lifting systems, additional units etc. can produce different values.*

## Key data

Model			OPX 20 iGo neo	OPX 25 iGo neo
1.1	Manufacturer		STILL	STILL
1.2	Type designation of the manufacturer		OPX 20 iGo neo	OPX 25 iGo neo
1.3	Drive		Electric	Electric
1.4	Operation		Stand-on truck	Stand-on truck
1.5	Load capacity/load	Q (kg)	2000	2500
1.6	Load centre of gravity distance	c (mm)	1200	1200
1.8	Load distance	x (mm)	1615 <sup>(2)</sup>	1615 <sup>(2)</sup>
1.9	Wheelbase	y (mm)	2717 <sup>(2)</sup>	2717 <sup>(2)</sup>

## Weights

Model			OPX 20 iGo neo	OPX 25 iGo neo
2.1	Net weight (including battery)	kg	1285 <sup>(2)</sup>	1310 <sup>(2)</sup>
2.2	Axle load with load, drive side / load side	kg	1211 / 2054	1279 / 2511
2.3	Axle load without load, drive side / load side	kg	988 / 277	997 / 293

## Wheels, chassis frame

Model			OPX 20 iGo neo	OPX 25 iGo neo
3.1	Tyres		Polyurethane	Polyurethane
3.2	Tyre size, drive side	mm	254 x 102	254 x 102
3.3	Tyre size, load side	mm	85 x 100	85 x 80
3.4	Auxiliary wheels	mm	150 x 50	150 x 50
3.5	Number of wheels, drive side / load side (x = driven)		1x - 1 / 2	1x - 1 / 4



Model			OPX 20 iGo neo	OPX 25 iGo neo
3.6	Track width, drive side	b <sub>10</sub> (mm)	474	474
3.7	Track width, load side	b <sub>11</sub> (mm)	348 (368 / 388 / 498)	348 (368 / 388 / 498)

### Basic dimensions

Model			OPX 20 iGo neo	OPX 25 iGo neo
4.2	Height (lift mast retracted)	h <sub>1</sub> (mm)	-	-
4.3	Free lift	h <sub>2</sub> (mm)	-	-
4.4	Lift	h <sub>3</sub> (mm)	130	130
4.5	Height (lift mast extended)	h <sub>4</sub> (mm)	-	-
4.6	Initial lift	h <sub>5</sub> (mm)	-	-
4.8	Standing height	h <sub>7</sub> (mm)	130	130
4.9	Height of the tie rod in driving position (min./max.)	h <sub>14</sub> (mm)	1250 <sup>(6)</sup>	1250 <sup>(6)</sup>
4.10	Height of load wheel supports	h <sub>8</sub> (mm)	-	-
4.14	Standing height, extended (with driver's platform that can be raised)	h <sub>12</sub> (mm)	1197	1197
4.15	Fork height, lowered	h <sub>13</sub> (mm)	85	85
4.19	Overall length	l <sub>1</sub> (mm)	3851	3851
4.20	Length including fork back	l <sub>2</sub> (mm)	1461	1461
4.21	Overall width (with chassis extension)	b <sub>1</sub> (mm)	800 (1000)	800 (1000)
4.22	Fork arm dimensions	s/e/l (mm)	61 (78 max) / 172 / 2390	61 (78 max) / 172 / 2390
4.24	Fork carriage width	b <sub>3</sub> (mm)	-	-
4.25	Width over forks	b <sub>5</sub> (mm)	520 (540 / 560 / 670)	520 (540 / 560 / 670)
4.31	Ground clearance under lift mast, with load	m <sub>1</sub> (mm)	-	-

## VDI datasheet iGo neo OPX 20, 25

Model			OPX 20 iGo neo	OPX 25 iGo neo
4.32	Ground clearance, centre of wheelbase	m <sub>2</sub> (mm)	24 / 154 <sup>(3)</sup>	24 / 154 <sup>(3)</sup>
4.34	Aisle width for pallet 800 x 16 lengthwise, raised	Ast (mm)	See lift mast table	See lift mast table
4.34.1	Aisle width for pallet 1000 x 1200 crosswise, raised	Ast (mm)	See lift mast table	See lift mast table
4.34.2	Aisle width for pallet 800 x 1200 crosswise, raised	Ast (mm)	See lift mast table	See lift mast table
4.35	Turning radius	W <sub>a</sub> (mm)	3075 <sup>(2)</sup> / 2967 <sup>(2)</sup> <sup>(3)</sup>	3075 <sup>(2)</sup> / 2967 <sup>(2)</sup> <sup>(3)</sup>

## Performance data

Model			OPX 20 iGo neo	OPX 25 iGo neo
5.1	Conventional driving speed, with / without load	km/h	9 / 12	9 / 12
5.1.1	Conventional driving speed, reverse, with / without load	km/h	8 / 11	8 / 11
5.1.2	Autonomous driving speed, with / without load	km/h	7.2	7.2
5.2	Lifting speed, with / without load	m/s	0.070 / 0.111	0.064 / 0.089
5.3	Lowering speed, with / without load	m/s	0.084 / 0.067	0.068 / 0.066
5.8	Max. climbing capability, with / without load	%	7%/12% <sup>(8)</sup> <sup>(9)</sup>	7%/12% <sup>(8)</sup> <sup>(9)</sup>
5.9	Acceleration time, with / without load	s	6.1 / 4.8	6.4 / 4.8
5.10	Service brake		Electromagnetic	Electromagnetic

## Traction motor

Model			OPX 20 iGo neo	OPX 25 iGo neo
6.1	Traction motor, power rating S2=60 min	kW	3	3
6.2	Lift motor, power at S3	kW	2.2 / 5%	2.2 / 5%
6.3	Battery in accordance with DIN 43531/35/36 A, B, C, no		No	No
6.4	Battery voltage / nominal capacity K <sub>5</sub>	V / Ah	24 / 345 - 465	24 / 345 - 465
6.5	Battery weight (± 5%)	kg	402	402
6.6	Energy consumption in accordance with the VDI cycle	kWh/h	0.46	0.52

**Miscellaneous**

Model			OPX 20 iGo neo	OPX 25 iGo neo
8.1	Type of traction controller		AC controller	AC controller
10.7	Sound pressure level (driver's ear)	dB (A)	< 70	< 70

- (1) With support for vertical pallet 1365 / 765 mm
- (2) For a fork length of 2390 mm / x=1615 mm / tie rod version; see table below for other fork dimensions
- (3) With the crane booms raised or the fork raised
- (4) + 114 mm with tray 54 or lithium-ion battery
- (5) With the specified load backrest (1290 mm, measured from the fork onwards)
- (6) With tiller adjustment option, h<sub>14</sub> adjustment range = +89 mm, -19 mm
- (7) Minimum ground clearance under the chassis with specified foot protection
- (8) On gradients/slopes with soft transitions (crane booms or forks raised), if possible
- (9) See the table below for the geometric limit values on gradients/slopes with hard transitions
- (10) In brackets: limit values for gradients/slopes with hard transitions or with foot protection (if different);  
due to manufacturing and assembly tolerances, it is recommended to reduce the nominal values by at least 1%
- (11) With a load of 1000 kg on the lift mast and a load of 1000 kg on the initial lift at the maximum initial lift height

**OPX 20/25 iGo neo forks (overview)**

	l (mm)	c (mm)	x <sup>(a)</sup> (mm)	y <sup>(a) (b)</sup> (mm)	Ast <sup>(b) (c)</sup> (mm)	Load at aisle width Ast
Forks with thrust rod	990	500	805	1907	3059	1 pallet 1000 x 1200 crosswise*
	1190	600	1005	2107	3081	1 pallet 800 x 1200 lengthwise
	1450	750	1265	2367	3363	Pallet 800 x l <sub>6</sub> lengthwise (l <sub>6</sub> = 2 x c)
	1650	850	1465	2567	3563	Pallet 800 x l <sub>6</sub> lengthwise (l <sub>6</sub> = 2 x c)
	1650	850	1105	2207	3473	Pallet 800 x l <sub>6</sub> lengthwise (l <sub>6</sub> = 2 x c)
	1800	900	1615	2717	3686	Pallet 800 x l <sub>6</sub> lengthwise (l <sub>6</sub> = 2 x c)
	2150	1100	1605	2707	3973	Pallet 800 x l <sub>6</sub> lengthwise (l <sub>6</sub> = 2 x c)
	2150	1100	1375	2477	3946	Pallet 800 x l <sub>6</sub> lengthwise (l <sub>6</sub> = 2 x c)

## VDI datasheet iGo neo OPX 20, 25

	l (mm)	c (mm)	x <sup>(a)</sup> (mm)	y <sup>(a) (b)</sup> (mm)	Ast <sup>(b) (c)</sup> (mm)	Load at aisle width Ast
	2390 <sup>(d)</sup>	1200	1845	2947	4305	3 pallets 800 x 1200 crosswise *
	2390 <sup>(e)</sup>	1200	1615	2717	4150	2 pallets 800 x 1200 lengthwise
Forks with tie rods	2390	1200	1845	2947	4171	2 pallets 800 x 1200 lengthwise
	2390	1200	1615	2717	4145	2 pallets 800 x 1200 lengthwise
	2900	1500	2125	3227	4738	Pallet 800 x l <sub>6</sub> lengthwise (l <sub>6</sub> = 2 x c)
	3100	1600	2125	3227	5003	2 pallets 800 x 1200 lengthwise + 1 pallet 800 x 1200 crosswise on the fork tips *

- (a) With forks lowered; -57 mm with fully raised forks on thrust rod version, +108 mm on tie rod version
- (b) + 114 mm with tray 54 or lithium-ion battery
- (c) With forks fully raised; +57 mm W<sub>a</sub> with forks lowered for thrust rod version, +108 mm W<sub>a</sub> for tie rod version
- (d) Long wheelbase suitable for holding 3 europallets crosswise
- (e) Short wheelbase suitable for holding 2 europallets lengthwise
- \* Holding pallets crosswise in relation to the forks is only allowed in Manual mode

OPX 20/25 iGo neo geometric climbing capability<sup>(a)</sup>

	l (mm)	c (mm)	x (mm)	Tray 53	Tray 54 or lithium-ion battery with foot protection
Forks with thrust rod	990	500	805	11.2 %	8.5%
	1190	600	1005	9.8%	7.4%
	1450	750	1265	8.7%	6.6%
	1650	850	1465	8.1%	6.1%
	1650	850	1105	9.3%	7.1%
	1800	900	1615	7.7%	5.8%
	2150	1100	1605	7.8%	5.8%
	2150	1100	1375	8.3%	6.3%
	2390	1200	1845	7.3%	5.5%
	2390	1200	1615	7.9%	5.9%
Forks with tie rods	2390	1200	1845	7.4%	5.6%
	2390	1200	1615	7.9%	5.9%

	<b>l (mm)</b>	<b>c (mm)</b>	<b>x (mm)</b>	<b>Tray 53</b>	<b>Tray 54 or lithium-ion battery with foot protection</b>
	2900	1500	2125	7.0%	5.3%
	3100	1600	2125	7.0%	5.3%

<sup>(a)</sup> Due to manufacturing and assembly tolerances, it is recommended to reduce the nominal values by at least 1%

## VDI datasheet iGo neo OPX-L 12, 20, 20 S

## VDI datasheet iGo neo OPX-L 12, 20, 20 S

**NOTE**

*This VDI datasheet specifies only the technical values for industrial trucks with standard equipment. Different tyres, lifting systems, additional units etc. can produce different values.*

**Key data**

Model			OPX-L 20 iGo neo	OPX-L 20 S iGo neo	OPX-L 12 iGo neo
1.1	Manufacturer		STILL	STILL	STILL
1.2	Type designation of the manufacturer		OPX-L 20 iGo neo	OPX-L 20 S iGo neo	OPX-L 12 iGo neo
1.3	Drive		Electric	Electric	Electric
1.4	Operation		Stand-on truck	Stand-on truck	Stand-on truck
1.5	Load capacity/load	Q (kg)	2000 / 1000 for mast lift	2000	1200
1.6	Load centre of gravity distance	c (mm)	1248 / 600 for mast lift <sup>(1)</sup>	1200	600
1.8	Load distance	x (mm)	1910 / 1782 <sup>(3)</sup>	1474 / 1310 <sup>(3)</sup>	670
1.9	Wheelbase	y (mm)	3225 / 3097 <sup>(3) (4)</sup>	2661 / 2497 <sup>(3) (4)</sup>	1823 <sup>(4)</sup>

**Weights**

Model			OPX-L 20 iGo neo	OPX-L 20 S iGo neo	OPX-L 12 iGo neo
2.1	Net weight including battery	kg	1674	1563	1415
2.2	Axle load with load, drive side / load side	kg	1629 / 2025	1231 / 2312	1015 / 1580
2.3	Axle load without load, drive side / load side	kg	1260 / 394	1111 / 432	967 / 428

**Wheels, chassis frame**

Model			OPX-L 20 iGo neo	OPX-L 20 S iGo neo	OPX-L 12 iGo neo
3.1	Tyres		Polyurethane	Polyurethane	Polyurethane
3.2	Tyre size, drive side	mm	254 x 102	254 x 102	254 x 102
3.3	Tyre size, load side	mm	85 x 80	85 x 80	85 x 60
3.4	Auxiliary wheels	mm	150 x 50	150 x 50	150 x 50
3.5	Number of wheels, drive side / load side (x = driven)		1x - 1/4	1x - 1/4	1x - 1/4
3.6	Track width, drive side	b <sub>10</sub> (mm)	474	474	474
3.7	Track width, load side	b <sub>11</sub> (mm)	370	368	(348) 388

**Basic dimensions**

Model			OPX-L 20 iGo neo	OPX-L 20 S iGo neo	OPX-L 12 iGo neo
4.2	Height (lift mast retracted)	h <sub>1</sub> (mm)	See lift mast table	1375 <sup>(5)</sup>	1375 <sup>(5)</sup>
4.3	Free lift	h <sub>2</sub> (mm)	See lift mast table	-	-
4.4	Lift	h <sub>3</sub> (mm)	800	700	700
4.5	Height (lift mast extended)	h <sub>4</sub> (mm)	See table be- low	2075 <sup>(5)</sup>	2075 <sup>(5)</sup>
4.6	Initial lift	h <sub>5</sub> (mm)	130	-	-
4.8	Standing height	h <sub>7</sub> (mm)	130	130	130
4.9	Steering wheel height in driving position (min./max.)	h <sub>14</sub> (mm)	1250 <sup>(6)</sup>	1250 <sup>(6)</sup>	1250 <sup>(6)</sup>
4.10	Height of load wheel supports	h <sub>8</sub> (mm)	85	-	-
4.14	Standing height, extended (with driver's platform that can be raised)	h <sub>12</sub> (mm)	1197	1197	1197
4.15	Fork height, lowered	h <sub>13</sub> (mm)	91	85	86
4.19	Overall length	l <sub>1</sub> (mm)	4176 <sup>(4)</sup>	3935 <sup>(4)</sup>	2703 <sup>(4)</sup>
4.20	Length including fork back	l <sub>2</sub> (mm)	1674 <sup>(4)</sup>	1545 <sup>(4)</sup>	1513 <sup>(4)</sup>

## VDI datasheet iGo neo OPX-L 12, 20, 20 S

Model			OPX-L 20 iGo neo	OPX-L 20 S iGo neo	OPX-L 12 iGo neo
4.21	Overall width (with chassis extension)	b <sub>1</sub> (mm)	800 (1000)	800 (1000)	800 (1000)
4.22	Fork dimensions	s/e/l (mm)	60 (72 max) / 200 / 1295	75 / 172 / 2390	55 / 172 / 1190
4.24	Fork carriage width	b <sub>3</sub> (mm)	711	792 <sup>(5)</sup>	796 <sup>(5)</sup>
4.25	Width over forks	b <sub>5</sub> (mm)	570	540	(520) 560
4.31	Ground clearance under lift mast, with load	m <sub>1</sub> (mm)	13 / 100 <sup>(3)</sup>	18 <sup>(7)</sup>	-
4.32	Ground clearance, centre of wheelbase	m <sub>2</sub>	25 / 155 <sup>(3)</sup>	10 / 710 <sup>(3)</sup>	30
4.34	Aisle width for pallet 800 x 16 lengthwise, raised	Ast (mm)	See lift mast table	4216 <sup>(4)</sup>	3045 <sup>(4)</sup>
4.34.1	Aisle width for pallet 1000 x 1200 crosswise, raised	Ast (mm)	-	-	-
4.34.2	Aisle width for pallet 800 x 1200 crosswise, raised	Ast (mm)	-	-	-
4.35	Turning radius	W <sub>a</sub> (mm)	3583 / 3455 <sup>(3)</sup> <sup>(4)</sup>	3019 / 2855 <sup>(3)</sup> <sup>(4)</sup>	2181 <sup>(4)</sup>

## Performance data

Model			OPX-L 20 iGo neo	OPX-L 20 S iGo neo	OPX-L 12 iGo neo
5.1	Conventional driving speed, with / without load	km/h	9 / 12	9 / 12	9 / 12
5.1.1	Conventional driving speed, reverse, with / without load	km/h	8 / 11	8 / 11	8 / 11
5.1.2	Autonomous driving speed, with / without load	km/h	7.2	7.2	7.2
5.2	Lifting speed, with / without load	m/s	0.159 / 0.253	0.095 / 0.176	0.135 / 0.218
5.3	Lowering speed, with / without load	m/s	0.218 / 0.240	0.13 / 0.13	0.130 / 0.122
5.8	Max. climbing capability, with / without load	%	7%/12% <sup>(8)</sup> (6.6%;5.3%) <sup>(10)</sup>	7%/12% (2.7%) <sup>(10)</sup>	7.8%/15% (6.2%) <sup>(10)</sup>
5.9	Acceleration time, with / without load	s	6.5 / 5.3	6.8 / 5.4	5.8 / 4.9
5.10	Service brake		Electromagnetic	Electromagnetic	Electromagnetic



**Traction motor**

Model			OPX-L 20 iGo neo	OPX-L 20 S iGo neo	OPX-L 12 iGo neo
6.1	Traction motor, power rating S2=60 min	kW	3	3	3
6.2	Lift motor, power at S3	kW	2.2 / 5%	2.2 / 5%	2.2 / 5%
6.3	Battery in accordance with DIN 43531/35/36 A, B, C, no		No	No	No
6.4	Battery voltage / nominal capacity K <sub>5</sub>	V / Ah	24 / 345 - 465	24 / 345 - 465	24 / 345 - 465
6.5	Battery weight (± 5%)	kg	402	402	402
6.6	Energy consumption in accordance with the VDI cycle	kWh/ h	0.55 / 0.52 <sup>(11)</sup>	0.83	0.54

**Miscellaneous**

Model			OPX-L 20 iGo neo	OPX-L 20 S iGo neo	OPX-L 12 iGo neo
8.1	Type of traction controller		AC controller	AC controller	AC controller
10.7	Sound pressure level (driver's ear)	dB (A)	< 70	< 70	< 70

- (1) With support for vertical pallet 1365 / 765 mm
- (2) For a fork length of 2390 mm / x=1615 mm / tie rod version; see table below for other fork dimensions
- (3) With the crane booms raised or the fork raised
- (4) + 114 mm with tray 54 or lithium-ion battery
- (5) With the specified load backrest (1290 mm, measured from the fork onwards)
- (6) With tiller adjustment option, h<sub>14</sub> adjustment range = +89 mm, -19 mm
- (7) Minimum ground clearance under the chassis with specified foot protection
- (8) On gradients/slopes with soft transitions (crane booms or forks raised), if possible
- (9) See the table below for the geometric limit values on gradients/slopes with hard transitions
- (10) In brackets: limit values for gradients/slopes with hard transitions or with foot protection (if different);  
due to manufacturing and assembly tolerances, it is recommended to reduce the nominal values by at least 1%
- (11) With a load of 1000 kg on the lift mast and a load of 1000 kg on the initial lift at the maximum initial lift height

## VDI datasheet iGo neo OPX-L 12, 20, 20 S

## OPX-L 20 iGo neo lift masts

Lift mast (type)			Telescopic
Lift mast height, lowered		$h_1$	1276
Lift mast height, free lift		$h_1$	1351
Free lift <sup>(a)</sup>		$h_2$	150
Lift height		$h_3$	1580 <sup>(b)</sup>
Lift mast height, extended		$h_4$	2066
Truck height, lift mast lowered	Standard		2200
	With pallet holder <sup>(b)</sup>		2200
Truck height, lift mast extended	Standard		2200
	With pallet holder <sup>(b)</sup>		3114
<sup>(a)</sup> With increased lift mast height $h_1$			
<sup>(b)</sup> With the specified load backrest on the accessory bracket for high loads			

## OPX-L 20 iGo neo aisle widths (with crane booms raised)

OPX-L 20 iGo neo aisle widths (with crane booms raised)					
Fork length	Dimensions of pallet (vertical) (mm)	Crane boom length (mm)	x (mm)	$W_a$ <sup>(c)</sup> (mm)	Load at aisle width $A_{st}$
1295	-	1207	1782	3455	2 pallets 800 x 1200 lengthwise
1295	165	1137	1617	3455	2 pallets 800 x 1200 lengthwise
<sup>(c)</sup> +114 mm with tray 54 or lithium-ion battery					

**OTHER CHARACTERS**

"Assistance" mode of operation

Overview. . . . . 83

**A**

Address of manufacturer. . . . . 1

Adjusting the truck alignment. . . . . 88

Audible signals. . . . . 105

**B**

Bottlenecks in the aisle. . . . . 63

**C**

Changing the remote control. . . . . 54

Charging. . . . . 52

Chassis extension. . . . . 10

Checks to be performed when commencing "Assistance" mode

Checks after switching on "Assistance" mode. . . . . 57

Safety information. . . . . 56

Visual inspections before switching on "Assistance" mode. . . . . 56

Cleaning. . . . . 110

Foot protection sensors. . . . . 111

Movement tracking sensors. . . . . 111

Safety laser scanner. . . . . 111

Collision avoidance. . . . . 75

Easy Protect. . . . . 77

Gradients (inclines/slopes). . . . . 71

Keeping roadways clear of obstacles. . . . . 73

Limits to the detection of obstacles. . . . . 69

Maintaining a safe distance from sloping edges and gradients. . . . . 71

Overhang for obstacles. . . . . 72

Components

Overview. . . . . 38

Conformity marking. . . . . 3

Contact details. . . . . 1

Copyright and trademark rights. . . . . 17

Crosswise roadway. . . . . 95

Customer-specific configuration. . . . . 12

**D**

Damage to safety systems. . . . . 28

Danger to employees. . . . . 33

Defects in safety systems. . . . . 28

Driving automatically without movement

tracking. . . . . 100

**E**

Easy Protect. . . . . 77

EC declaration of conformity in accordance with the Machinery Directive. . . . . 4

Emergency off switch. . . . . 49

Emergency stop. . . . . 96

End of the racking. . . . . 94

**F**

Foot protection sensors

Cleaning. . . . . 111

Function. . . . . 46

**H**

Hazards and countermeasures. . . . . 31

**I**

Identifying the operator. . . . . 93

iGo neo buttons (functions). . . . . 48

Improper use. . . . . 6

Information symbols. . . . . 17

Intended use. . . . . 5

in "Assistance" mode

Obstacles in the roadway. . . . . 75

**K**

Keypad (functions). . . . . 47

**L**

Labelling points. . . . . 36

LED signalling units

Information and warning signals. . . . . 39

Truck alignment display. . . . . 40

LED signals from the movement tracking

sensors. . . . . 42

Lifting and lowering the fork carriage. . . . . 101

Lint filter. . . . . 5

**M**

Maintenance. . . . . 118

1000 hours / yearly. . . . . 120

Safety regulations. . . . . 119

Medical equipment. . . . . 29

Minimum distance to obstacles. . . . . 76

Misuse of safety systems. . . . . 28

Modifying the truck. . . . .	26, 27
Modifying the truck parameters. . . . .	27
Movement tracking sensors. . . . .	42
Cleaning. . . . .	111
Signals from the indicator LEDs. . . . .	42
Moving the stop position next to the operator to the next pallet. . . . .	98

**O**

Operating company	
Duties. . . . .	22
Operating instructions	
Storing. . . . .	16
Validity. . . . .	16
Operating "Assistance" mode	
Adjusting the truck alignment. . . . .	88
Connecting the remote control. . . . .	86
Driving automatically without movement tracking. . . . .	100
Emergency stop. . . . .	96
Identifying the operator. . . . .	93
Lifting and lowering the fork carriage. . . . .	101
Moving the stop position next to the operator to the next pallet. . . . .	98
Positioning in the aisle. . . . .	89
Setting the drive programme. . . . .	104
Specifying the distance to the rack contour. . . . .	89
Stopping at the end of the racking. . . . .	94
Stopping before a crosswise roadway. . . . .	94
Switching between ACTIVE / PAUSED. . . . .	91
Switching on. . . . .	86
Z picking. . . . .	103
Operator	
Duties. . . . .	23
Responsibility for the remote control. . . . .	23
Operator detection. . . . .	41, 43
Movement tracking sensors. . . . .	42
Overhang for obstacles. . . . .	72

**P**

Positioning in the aisle. . . . .	89
Position tracking of the remote control. . . . .	43
Priority rules in mixed Manual/ Assistance traffic. . . . .	68

**R**

Remote control. . . . .	52
Buttons. . . . .	51
Changing the remote control. . . . .	54
Checking the battery charge. . . . .	52
Display LEDs. . . . .	50
Functions. . . . .	50
Registering a remote control on the truck. . . . .	54
Switching on and off. . . . .	50
Vibration signals. . . . .	50
Required safety distances in the aisle. . . . .	11
Requirements for load carriers and loads. . . . .	8
Requirements for the ground conditions of roadways. . . . .	14
Requirements for the place of use. . . . .	6
Residual dangers, residual risks. . . . .	30
Retrofitting. . . . .	26
Roadways	
Keeping roadways clear of obstacles. . . . .	73
Minimum distance to obstacles. . . . .	74
Suitable roadways. . . . .	14

**S**

Safety distances. . . . .	11
Safety inspection. . . . .	35
Safety laser scanner	
Function. . . . .	44
Safety laser scanners	
Cleaning. . . . .	111
Safety regulations in "Assistance" mode. . . . .	61
Averting the risk of collision using the emergency off switches. . . . .	62
Bottlenecks in the aisle. . . . .	63
Information and warning signals. . . . .	65
Lifting of persons with the forks (not permitted). . . . .	66
Limitations of the foot protection sensors in the event of impermissible or poor application conditions. . . . .	62
Load individual pallets onto trucks with long forks from the side. . . . .	64
Maximum permissible dimensions of load carriers and loads. . . . .	64
Observe the risk of accident due to incorrect detection of the operator. . . . .	67

Priority rules in mixed "Manual/Assistance" traffic. . . . .	68	Switching on (truck). . . . .	85
Risk of accident due to excessive speed. . . . .	65	<b>T</b>	
Risk of accident due to smoke in the event of fire or due to view-obstructing vapours. . . . .	66	Technical data	
Risk of accident from crossing the roadway immediately in front of the truck. . . . .	63	Dimensions of iGo neo OPX-L 12. . . . .	125
Risk of crushing feet. . . . .	61	Dimensions of iGo neo OPX-L 20. . . . .	126
Safe storage of the remote control. . . . .	67	Dimensions of iGo neo OPX-L 20 S. . . . .	127
Switch "Assistance" mode to PAUSED before entering the truck. . . . .	62	Dimensions of iGo neo OPX 20, 25. . . . .	124
Transport of people and jumping onto the truck (not permitted). . . . .	66	VDI datasheet: iGo neo OPX-L 12, 20, 20 S. . . . .	134
Wear safety shoes. . . . .	61	VDI datasheet: iGo neo OPX 20, 25. . . . .	128
Setting the drive programme. . . . .	104	Transport. . . . .	114
Specifying the distance to the rack contour. . . . .	89	Driving on loading bridges. . . . .	115
Stopping at the end of the racking. . . . .	94, 95	Impermissible crane loading. . . . .	114
Switching off the truck. . . . .	85	Lashing down the truck. . . . .	114
Switching off (truck). . . . .	85	<b>W</b>	
Switching on the truck. . . . .	85	Warning regarding non-genuine parts. . . . .	27
		Warning sounds in "Assistance" mode. . . . .	105
		<b>Z</b>	
		Z picking. . . . .	103





STILL GmbH

50108046112 EN - 11/2021 - 04