



Operators manual

E-Stacker

SXV-CB 10



2260

STILL SXV-CB 10 series 500237

Preface

The STILL SXV-CB 10 is a versatile, electric, counterbalance industrial truck, hereafter referred to as “truck”, designed to operate in tight spaces with maximum ergonomics and operator safety. The truck is open on both sides to allow the operator to exit and enter the truck efficiently. As standard the control panel is located on the mast side but options are available that allows the operator to stand sideways in the truck for longer traveling distances.

The STILL SXV-CB 10 is a heavy-duty machine designed for maximum performance and driver safety. Built to deliver the best overall economy with extensive driving – long hours, day after day, year after year.

Thanks to the STILL SXV-CB 10’s long life time you not only get an optimal overall economy, you also contribute to a reduced environmental impact and a reduction in the waste of resources.

The STILL SXV-CB 10 is produced by:

Actil Warehouse Trucks AB

Flemma Muggebo 2

SE-58578 Vreta Kloster

Sweden

Telephone: +46 (0) 13 602 00

Mail: info@actil.se

Web: www.actil.se

For:

STILL GmbH

Berzeliusstraße 10

22113 Hamburg

Telephone: +46 (0) 40 7339-0

Telefax: +49 (0) 40 7339-1622

E-Mail: info@still.de

Web: www.still.de

The STILL SXV-CB 10 is a certified STILL-product, which in terms means that all contacts for support or technical issues should be communicated solely to STILL GmbH.

Table of contents

Taking Delivery of your truck	8	Driving the truck	22
Identification label.....	9	Accelerating	22
Capacity label	9	Braking	22
Truck labels.....	10	Steering.....	22
EC/EU declaration of conformity.....	11	Fork carriage and attachments.....	24
Competent person.....	11	Manually adjusting fork arm position.....	24
Symbols used in manual.....	12	Parking the truck.....	24
Intended use.....	12	Driving under load	24
Medical devices	12	Load backrest (optional)	25
Working areas	12	Emergency lowering	26
Driving routes and operating conditions...12		Battery	27
Danger areas.....	14	Battery Type.....	27
Impermissible use.....	14	Service and inspection	27
Damages and defects	14	Charging the battery	28
Stability.....	14	Before charging.....	28
Speed reduction systems	15	When charging is completed	28
Pressure sensor	15	Removing a fixed battery.....	28
Lift height and steering sensor.....	15	Battery exchange system.....	28
Operating on a gradient	15	Electrical interface for external systems	29
Over Head Guard – OHG	15	Transporting the truck using a lorry	30
Pre-shift checks	16	Loading/offloading procedures - Lorry	30
Checking Hydraulic oil level.....	16	Loading/offloading procedures - Crane....	30
Regular maintenance	17	Lashing procedures.....	30
Cleaning the truck	17	Service.....	31
Disposing of components and batteries.....	17	Periodic safety inspection.....	31
Vehicle overview	18	Software and parameters.....	31
Main operators panel.....	19	Service intervals.....	32
Secondary operators panel (optional).....	19	Special service point	32
Compartment display	20	Influence of the service schedule	32
Operation	21	Technical data.....	39
Enter and exiting the truck.....	21	Mast data.....	41
Switching the truck on and off	21	Fluids and consumables.....	41
Switching the truck on.....	21	Error codes and trouble shooting	42
Switching of the truck.....	22	Error codes in the display	42
		System Fault (A).....	42
		Li-ion Battery Fault (L).....	43

Power Steer Fault (P).....	45
Curtis Fault (C/d)	49

Taking Delivery of your truck

Before the truck leaves our factory, we inspect it carefully to guarantee it is in flawless condition upon on delivery and the equipment that is included corresponds to your order. We ask that you inspect the delivered truck to ensure it matches your order and that no damage has occurred during transportation.

The following technical documents comes with each delivered truck:

- Operating instructions,
- Operating instructions for the additional attachment (if applicable)
- EC/EU declaration of conformity

These operating instructions is designed to provide you all necessary information, and contains important information regarding required safety rules that must be followed.

In following the manual, you will avoid and prevent incidents as well as enable the full use of the truck throughout its lifespan.

The trucks operational capacity, efficiency, and lifespan relies on:

- Correct use.
- Daily checks of the truck.
- Regular performance of maintenance activities.

Advice for operating and maintaining customized trucks is provided on delivery.

The designations used in the manual: front – rear - left - right - always refer to the installation position of the parts described, with forwards as the drive direction with fork arms forward.

Service should only be carried out by qualified personnel approved by STILL GmbH

With orders for parts, please specify the following along with the parts numbers:

Truck model	
Serial number/year	
Handover date	

When you receive the truck, copy this data from the identification plates of the units into these operating instructions.

The manufacturer assumes no liability for hazards and problems arising from incorrect use or maintenance of the truck.

NOTE: In the event of repairs, only use genuine spare parts from the manufacturer. This is the only way to guarantee that the truck will remain in the same technical condition as when it was received.

The company, i.e. the manufacturer, is constantly engaged in the further development of its products.

We ask for your understanding that, in the interest of progress, illustrations and technical data are subject to technical modifications in terms of form, equipment and expertise.

For this reason, no claims can be asserted on the basis of the following data, figures and descriptions in these operating instructions.

These operating instructions must not be reproduced, translated or made accessible to third parties without the written approval of the manufacturer.

Identification label

The truck is labeled with an identification label. This is located on the front of the chassis, behind the mast. Below is an example of this label.

Type Model	E10 TFY
Serial No. Serien-Nr.	8917-20-2101
Intern. No. Intern-No.	200549
Manufacture year Baujahr	2020
Weight without battery Leergewicht	1985 kg
Max. battery weight Höchstgewicht der Batterie	255 kg
Min. battery weight Mindestgewicht der Batterie	230 kg
Battery voltage Batteri-Spannung	24 V
Drive motor rating Antriebsmotorleistung	1 x 3,0 kW

	
ACTIL WAREHOUSE TRUCKS AB	
S-585 78 Vreta Kloster, Sweden Tel +46 (0)13-602 00 www.actil.se	

This label contains information of the truck's unique serial number, essential weight and information of the manufacturers CE approval.

When contacting your service partner, the information in the identification label should be available.

Capacity label

The trucks capacity label is located on the overhead guard, on the right hand side of the truck.

This label describes the capacity for which the truck is approved. The load capacity of the truck is determined by the lift mast type and the lift height of the installed mast.

DANGER The values specified in the load capacity diagram apply to compact homogeneous loads and must not be exceeded, as this will impair the stability of the truck and the rigidity of the fork arms and lift mast.

Below is an example of the load capacity label.

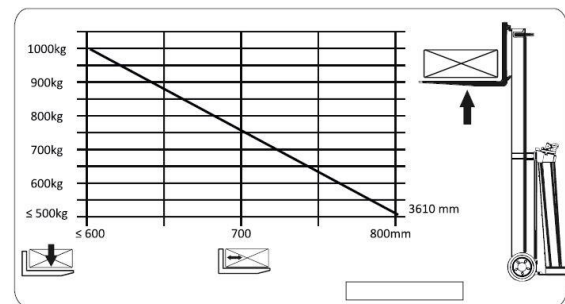

The maximum permissible load is determined by the centre of gravity distance between the load and the back of the fork arms, and the lift height.

Trace a vertical line from the load distance to its point of intersection with the line for a lift height of 3610 mm. Read of the permissible load to the left of the point of intersection with the horizontal line.

For example, the truck above has a capacity of 1000 kg at load distance 600 mm, up to 3610 mm lift height.

Or, 750 kg at load distance 700 mm, up to 3610 mm.

Truck labels

The following labels are present on the truck. These labels inform the operator of potential hazards and must be kept in good condition.



This label is found on the truck where particular care and attention is required. The operator should refer to the appropriate section in these operating instructions.



This label indicates an area that may have an elevated risk of crushing or shearing injuries. Use extreme caution around these areas.



This label states that it is forbidden for personnel to stand on the forks, or walk under raised forks with or without cargo.



This label indicates, from the manufacturer, approved points for lifting of the truck. The truck shall not be lifted using any other points than the marked ones.



This label indicates the max/min level of hydraulic oil. This is located on the hydraulic tank or in its direct vicinity.

EC/EU declaration of conformity

During manufacture:

- All safety requirements, of the relevant EC directives were fulfilled,
- All conformity assessment procedures stipulated in the applicable directives was carried out, and fulfilled.

This is attested by the CE mark shown on the identification label.

The manufacturer declares that the truck complies with the provisions of the EC machinery directive, and other EC/EU directives if applicable, that are valid at the time of marketing. This is confirmed by the EC/EU declaration of conformity and by the CE labelling on the identification label.

The EC/EU declaration of conformity document is supplied with the truck. The declaration explains the conformity with the provisions of the EC machinery directive.

An unauthorised, independent structural change or addition to the truck can compromise safety, thus invalidating the EC/EU declaration of conformity.

The EC/EU declaration of conformity must be carefully stored and made available to the responsible authorities if necessary. It must also be handed over to the new owner if the truck is sold on.

Only in the event that the truck manufacturer is no longer in business and there is no successor in the interest to the business, may the user arrange for a modification or alteration to a powered truck, provided, however, that the user:

- Arranges for the modification or alteration to be designed, tested and implemented by an engineer(s) expert in trucks and their safety,

- maintains a permanent record of the design, test(s) and implementation of the modification or alteration,
- approves and makes appropriate changes to the capacity plate(s), decals, tags and instruction handbook, and
- affixes a permanent and readily visible label to the truck stating the manner in which the truck has been modified or altered, together with the date of the modification or alteration and the name and address of the organization that accomplished those tasks.

Competent person

A competent person is a specialist in the field of trucks who has:

- Successfully completed training, as at least a service engineer for trucks
- Many years of professional experience with trucks
- Knowledge of the accident prevention regulations
- Knowledge of the relevant national technical regulations

The competent person is able to assess the condition of trucks in terms of health and safety.

Symbols used in manual

The terms DANGER, WARNING, CAUTION and NOTE are used in this manual. They are intended to draw attention to specific essential information.

- **DANGER** – Failure to comply may result in serious injuries to personnel and/or equipment
- **WARNING** – Failure to comply may result in an elevated risk for personnel and/or equipment
- **CAUTION** – Failure to comply may result in an elevated risk for equipment
- **NOTE** – *These sections contains technical information that may not be obvious to the operator or the technician.*

Intended use

The truck may only be used as permitted and only for moving and lifting loads indicated on the capacity label. The operator/driver of the truck shall have proper training and, according to national law, the correct competence level for the truck model.

Medical devices

If a driver has active medical equipment such as a pace makers, defibrillator, cochlear implant, insulin pump or hearing aid, there is a possibility that the capabilities of the driver could be impaired.

The operating company must take drivers whose capabilities are restricted due to implanted or body-worn medical equipment into account in the hazard assessment. The instructions of the physician and of the manufacturer of the medical equipment must be followed.

Risk from non-ionising radiation from retrofitted devices (e.g. radio transmitter).

Persons with active or non-active implanted medical equipment must not be exposed to excessive non-ionising radiation from the electromagnetic fields of retrofitted devices. The guidelines from the respective device manufacturer must be followed. If necessary, fit a notice warning about non-ionising radiation within the field of vision of the driver.

Working areas

The truck may only be used in areas approved by the operating company and the manufacturer.

In operating areas with magnetic fields that have a magnetic flux density greater than 5 mT, unintentional truck and lift mast movements cannot be entirely excluded under unfavourable circumstances. In this case components developed especially for this purpose must be used.

Driving routes and operating conditions

The truck is only allowed to be used in driving routes/conditions that follows the below criteria's:

- The truck is only to be used indoors. The truck shall not be used outdoors, under any circumstances.
- Routes shall consist of high-quality concrete floor, smooth asphalt or of similar quality.
- Obstacles in the floor such as rails, thresholds or similar shall be levelled and, if necessary, covered with ramps suitable for the truck.
- Routes should not consist of sharp curves, excessive slopes and gates which are too narrow or too low.
- Inclines shall not exceed the limits set by the manufacturer.

- The truck is, as standard, equipped for continuous use in ambient temperatures spanning from +5°C - +25°C. The truck may be used in temperatures up to, but not exceeding, +40°C and for no longer than 1 hour.
- The truck shall not be used in areas with heights exceeding 2000 m above sea level.
- The truck shall not be used in corrosive, salty or other aggressive environments unless agreed with the manufacturer.
- Driving routes shall be properly illuminated. If this is not the case, then the truck shall be equipped with working lights.

Danger areas

Danger areas are those areas in which persons are in danger as a result of the movements of trucks, their operating equipment, their load carrying devices (e.g. their attachments) or the loaded goods. This also includes the area which can be reached by falling goods or lowering or falling operating equipment and devices.

People must not stand in the danger area of the truck.

Impermissible use

The operator or the operating company, and not the manufacturer, is solely liable if the truck is used in a manner that is not permitted.

The following list is examples of impermissible use:

- Use the truck for transportation of people.
- Operation in areas where there is a risk of fire or explosion.
- Stacking/unstacking in slopes.
- Standing on the fork arms when raised.
- Exceed the trucks capacity or load center.
- Use the truck for towing/pushing cargo.
- Modify the truck, or retrofit equipment from independent company, without the manufacturer's approval.

Damages and defects

Damages or other defects must be reported to the supervisor immediately. Trucks and attachments which are not safe to operate may

not be used until they have been properly repaired.

Supervisor shall contact their local STILL service partner for further actions, in the event of damages or other defects.

Safety installations and switches may not be removed or rendered unusable. Specified settings may only be changed with the approval of STILL GmbH, and performed by a certified technician.

Only original spare parts shall be used in order to ensure proper function and safety of the truck.

Stability

Even beyond the narrow danger areas of the truck itself, a residual risk cannot be excluded. Persons in the area around the truck must exercise a heightened degree of awareness, so that they can react immediately in the event of any malfunction, incident or breakdown.

Stability is only guaranteed if the truck is used according to its intended purpose.

Stability will not be guaranteed in the event of:

- cornering at excessive speeds.
- moving with the load raised.
- moving with a load that is protruding to the side (e.g. sideshift).
- turning and driving diagonally across descents or ascents.
- driving on descents or ascents with the load on the downhill side.
- loads that are too wide.
- driving with a swinging load.
- ramp edges or steps.

Speed reduction systems

Pressure sensor

The hydraulic system is equipped with a pressure sensitive sensor. When a heavy load is lifted the truck will reduce the driving speed and the lowering speed of the forks according to set parameters in the motor controller. The sensor is also used to prevent overloading.

The parameters for the pressure sensor can be adjusted to fit the customer's need.

DANGER Incorrect adjustments of these parameters may result in serious danger to both personnel and equipment. This must only be done by a certified technician and within the limits of the manufacturer's min/max values.

Contact your service partner.

Lift height and steering sensor

The motor controller monitors the truck's current steering angle and will lower the driving speed depending on the steering angle.

When the fork carriage is lifted above the first stage of the mast, the motor controller will reduce the truck's maximum speed. Standard setup is a speed reduction by 50%.

DANGER Incorrect adjustments of these parameters may result in serious danger to both personnel and equipment. This must only be done by a certified technician and within the limits of the manufacturer's min/max values.

Contact your service partner.

Operating on a gradient

Due to the specified minimum braking distance and stability values, the truck shall not be operated on gradients greater than 15% without load.

The maximum allowed gradient when carrying full load is 8%.

Please contact your service partner before negotiating steeper gradients.

In the case of tip-over

The stability of your truck is ensured if used properly and as intended. Should the truck tip over during an unapproved application or due to incorrect operation, always follow the instructions depicted below.

- Stay inside the truck,
- Hold on tight,
- Brace feet and knees against the truck chassis,
- Lean away from the tipping direction.

Over Head Guard – OHG

The truck is equipped with an over head guard (hereafter referred to as "OHG"). The OHG is considered as safety equipment and has been tested according to CE regulations.

DANGER: The OHG of the truck is a critical part of the truck's structure. The truck must never be operated without an OHG. If the OHG is damaged or modified without approval, the safety of the operator is compromised.

WARNING: If the OHG is equipped with a clear view glass panel this must be examined for damages regularly. If the glass panel is damaged it needs immediate replacing.

Contact your service partner

Pre-shift checks

The following listed points must be checked at the start of each shift. If errors or problems are found, alert your supervisor.

- Visual inspection of chassi for critical damages,
- Roof panel, check condition and visibility,
- Check tires and rims for damages,
- Check antistatic belt (special equipment) and ensure floor contact,
- Test brakes,
- Test steering, end to end,
- Check condition of the drive battery,
- Check electrical system (e.g lighting, warning units etc.),
- Check hydraulic oil level,
- Inspect for hydraulic leaks,
- Perform a fully extended lift without cargo,
- Check fork arms and fork attachment.

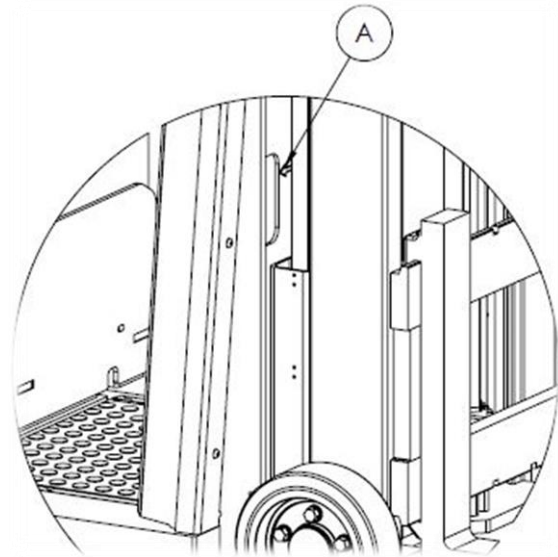

Fig 1.1

The oil level will be marked with a “MAX”, “MIN” mark. The location of these marks depends on the lift mast mounted on the truck and may vary from different trucks.

The oil level should be within these “MIN and “MAX” marks when the lift mast is fully lowered.

Checking Hydraulic oil level

The hydraulic oil level of the truck must be checked regularly to ensure the function of the trucks lift mast, and if applicable, hydraulic attachments.

The hydraulic oil tank is located in the front section of the chassi, behind the lift mast (see fig. 1.1). On the front panel of the chassi is an inspection hole (A) to check the level without having to open the hydraulic compartment.

Regular maintenance

Performing the maintenance tasks listed will increase the availability of the truck and help maintain its value.

Carry out this work as frequently as possible in accordance with the application conditions.

- Clean the truck, see section “Cleaning the truck”.
- Clean and lubricate lift mast chain, fork attachments and similar.

Cleaning the truck

CAUTION: The truck must not be cleaned using water/pressurized water due to the risk of serious damages to electronics.

The frequency required for cleaning of the truck depends on the application. If the truck is operating in corrosive environments and exposed to, for instance, salt, water, fertiliser, chemicals or cement etc. the truck must be thoroughly cleaned after each assignment. Always wear protective equipment suitable for the cleaning material.

For the operator panels, only use a dry cloth or compressed air. Powerful degreasing materials may damage the electrical components in the panels.

Disposing of components and batteries

The truck is composed of different materials. If components or batteries need to be replaced and disposed of, the national regulations must be observed with regard to:

- Disposal,
- Treatment,
- Recycling.

NOTE: The documentation provided by the battery manufacturer must be observed when disposing of batteries.

ENVIRONMENT NOTE

We recommend working with a waste management company for disposal requirements.

Vehicle overview

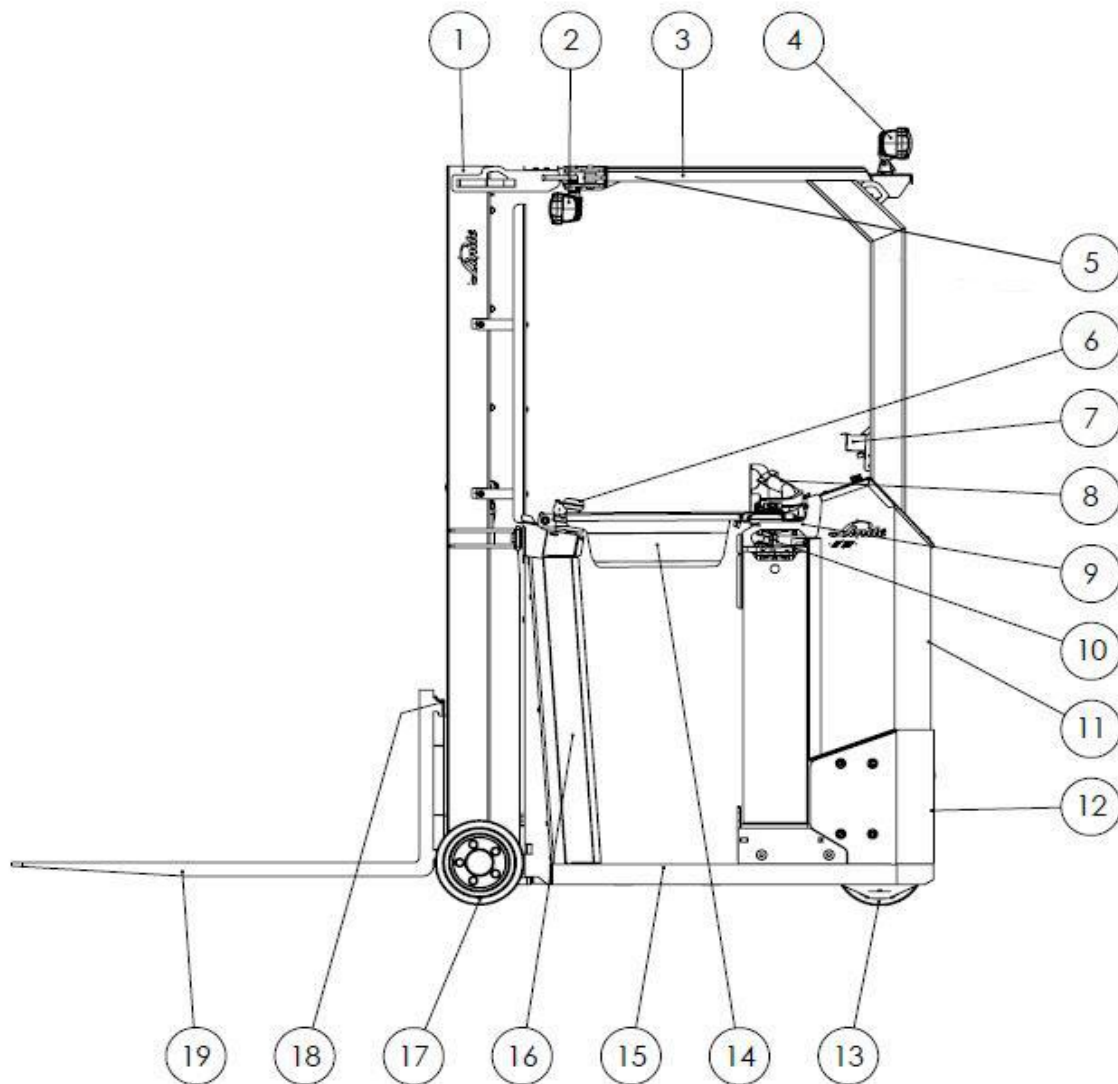

Fig 2.1

- | | |
|--|---|
| 1. Lift mast | 10. Battery panel/battery locking system |
| 2. Mounting plate – fork direction for bluespot etc. (optional) | 11. Access panel for motor compartment |
| 3. Over Head Guard - OHG | 12. Bumper/protection panel for gearbox |
| 4. Mounting plate – battery direction for bluespot etc. (optional) | 13. Drive wheel |
| 5. Lift capacity diagram | 14. Foldable side gate – left side (optional) |
| 6. Main operator panel | 15. Floor panel/Dead mans switch |
| 7. Accessory bar/storage compartment (optional) | 16. Access panel for hydraulics compartment |
| 8. Secondary operator panel (optional) | 17. Load wheels |
| 9. Curtis software connection point (under battery panel) | 18. Fork arrest |
| | 19. Forks |

Main operators panel

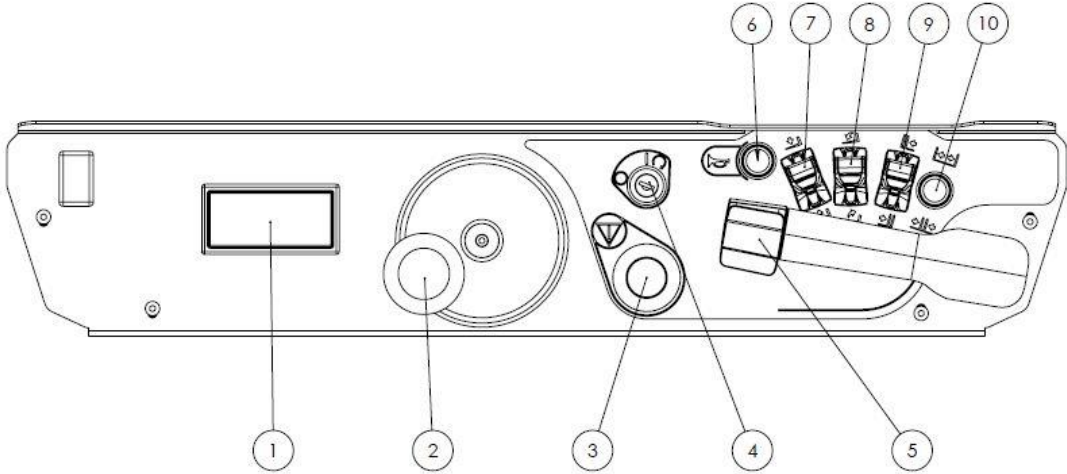

Fig 3.1

- 1. Battery indicator display
- 2. Steering wheel
- 3. Emergency off switch
- 4. Start key
- 5. Throttle control
- 6. Horn
- 7. Fork carriage lift/lower
- 8. Fork carriage tilt up/down
- 9. Fork carriage sideshift left/right
- 10. Forkspread in/out

Secondary operators panel (optional)

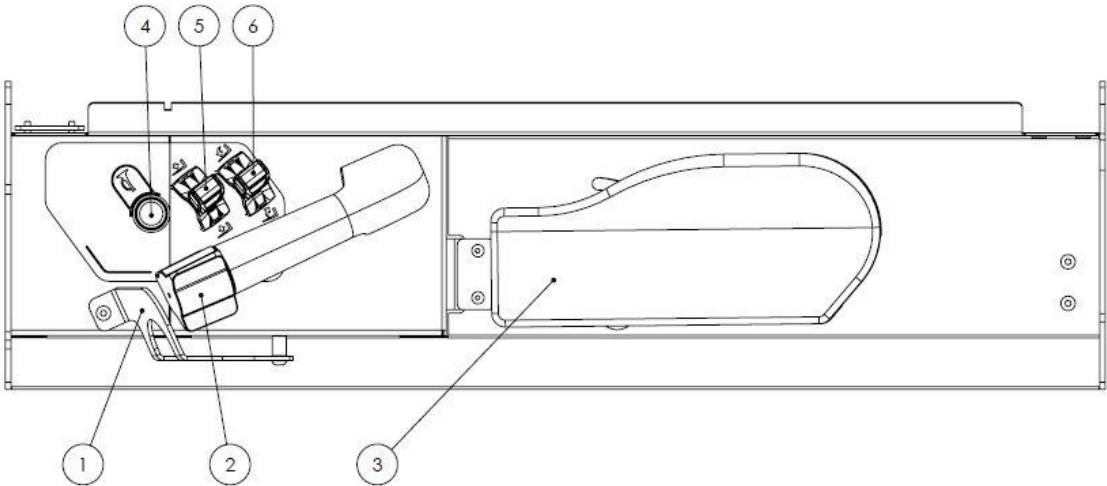

Fig 3.2

- 1. Throttle control protection
- 2. Throttle control
- 3. Armrest
- 4. Horn
- 5. Fork carriage lift/lower
- 6. Fork carriage tilt up/down

Compartment display

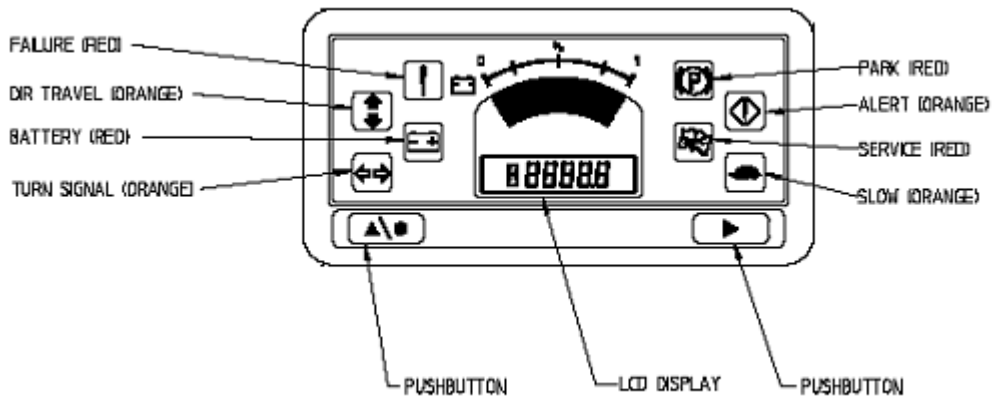











Fig 3.3

- 
 When the drive wheel is straight, the orange symbol is lit.
- 
 In a turn, the speed reduction is activated and the orange symbol is lit.
- 
 In the event of an error, the red symbol is lit and an error code can be seen on the display.
- 
 When the battery needs to be charged soon, the red battery symbol is lit.
- 
 When the parking brake is activated, the red symbol is lit.
- 
 When it is time for a service, the red symbol is lit.
- 
 If any errors occur that are due to operation, the orange symbol is lit.
- 
 During e.g. high lifts, the speed is reduced and the orange symbol is lit.
- 
 The hour meter is activated e.g. the dead man's switch is activated

NOTE: When the truck is started it performs its start-up sequence. During this sequence the display may show different lights and information. When the truck has performed its start-up sequence the battery charging level appears along with the red light that indicates the parking brake being activated. The truck is now ready for operation.

If any errors occur during operation, the error light activates and an error code appears in the display.

Please refer to "Error codes and troubleshooting" for further info.

The error codes need to be communicated to a service technician upon an error.

Operation

Enter and exiting the truck

As standard the truck is open on both sides of the truck to ensure easy access to the operator compartment. The truck has a very low entry height for easy access.

The operator must ensure that special care is taken when entering or exiting the truck. The truck must be at a complete stand still both when entering and exiting the truck.

The handles for the throttle controls, or the steering wheel, shall not be used as an aid when entering or exiting the truck.

In cases where a foldable side gate is mounted (special equipment, one side only), this needs to be opened to gain access to the compartment on the affected side. Please see fig 4.1.

The folding side gate is secured by a locking mechanism on the battery side of the truck. Release the lock and rotate the side gate towards the mast. A pneumatic cylinder will keep the side gate in an upright position.

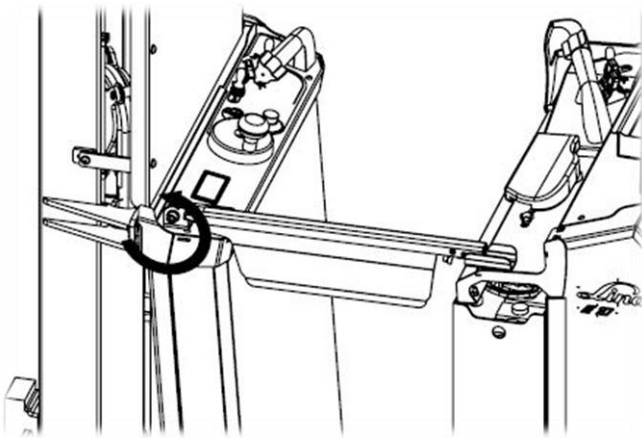

Fig 4.1

WARNING: The folding side gate is only intended as an ergonomic support for the operator, and is therefore not considered as a safety feature. The truck is drivable both with the folding side gate opened and closed.

Switching the truck on and off

NOTE: Any number references in the following sections refers to the main operator panel overview fig 3.1.

Switching the truck on

DANGER: Ensure that no other personnel stands in the direct vicinity of the truck during the start-up since the homing of the gear may cause the truck to slightly shift sideways.

NOTE: The entire floor panel/floor mat acts as a dead man's switch/presence control. Accelerators or joysticks may not be actuated before start-up sequence has been made and run-time hours appear in the display. To recommission, turn of the truck and restart.

NOTE: The dead mans switch/presence control must be cycled at least one time during, or after, the start up sequence. This is to ensure the function of the switch for safety reasons. The error code C47 will appear and the truck is blocked until the switch has been cycled.

As standard the truck is fitted with a start-key (4).

Switching on the truck is made by following the below steps:

- Ensure that the battery is connected properly,
- Enter the truck, preferably standing on one of the side beams.

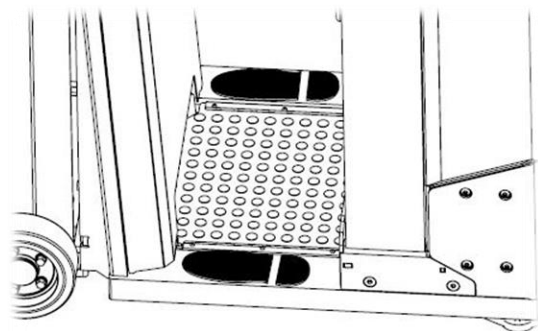

Fig 4.2

- If necessary, rotate the emergency off switch (3) to release it,
- Turn the start-key (4) clockwise and hold it to its end position until the display lights up, and release the key. (key is spring loaded)
- Step on to the floor panel/floor mat

The truck will now perform a system check to ensure that all systems are fully operational. During this system check the gearbox will perform a homing sequence to find its starting position.

- After the sequence is completed, the error code C47 may appear in the display. This error code means that the dead mans switch must be cycled before operation. Step of the floor panel/floor mat and immediately back on to remove this error code.

When the start-up sequence and systems check have been made the battery display/indicator will show charging level and runt-time hours.

The truck is now ready for operation.

Switching of the truck

Before switching of the truck, the truck must be brought to a complete standstill. When the truck is switched off a loss of steering occurs and the magnetic brakes activates.

Switching off the truck is made by turning the start key (4) counter-clockwise to its end position.

The truck is now switched off.

Driving the truck

DANGER: The parameters for braking, accelerating and power steering can be adjusted to fit the customer's needs. This must only be done by a certified technician, and within the limits of the manufacturer's min/max values. Contact your service partner.

Always ensure sufficient visibility when carrying loads. The preferred driving direction when carrying loads is in the battery direction.

NOTE: *The truck can be fitted with a secondary operator's panel (optional). Fork carriage lift/lower and fork carriage tilt up/down is then also available on the secondary panel. See fig 3.2.*

NOTE: *The entire floor panel/floor mat acts as a dead mans switch/presence control. This switch must be activated, e.g. the operator must stand on the floor panel, in order to activate and allow any of the functions*

in the truck. Once the operator steps of the floor panel the electric brake is applied.

Accelerating

Acceleration is performed by rotating the speed throttle (5) in the direction to travel. The throttle system is proportional which means that higher traveling speeds are achieved by rotating the throttle handle (5) further in the desired direction.

CAUTION: Ensure that the forks are lifted off the floor before accelerating, to avoid damages to the truck or the floor.

Braking

Braking of the truck can be made in two ways.

- Releasing the throttle (5) to neutral position activates the electrical regenerative current braking. This results in the truck slowly coming to a stop.
- By turning the throttle (5) in the opposite direction, from the traveling direction, the brake force is increased.

If the throttle (5) is turned in the opposite direction the truck will come to a short standstill before accelerating in the direction which the speed throttle is activated to.

Steering

The trucks power steering system is fully electric.

- To steer to the left, rotate the steering wheel (2) to the left,
- To steer to the right, rotate the steering wheel (2) to the right.

The power steering system is adaptive which means that the higher the traveling speed is the more rotations, end to end, on the steering wheel is needed. This enables a safer and more controlled travel at higher speeds, as well as more efficient manoeuvring at lower speeds.

- At maximum speed – 5 rotations end to end,
- At minimum speed – 3 rotations end to end.

To further improve visibility the truck can be fitted with a wide-angle rear-view mirror (option). This option can greatly enhance the visibility behind the truck and can be mounted on any flat metal surface.

Contact your dealer for more information

Fork carriage and attachments

NOTE: The truck can be fitted with a secondary operator's panel (optional). Fork carriage lift/lower and fork carriage tilt up/down is then also available on the secondary panel. Please see fig 3.2.

To lift the fork carriage, pull the fork joystick (7) backwards. To lower the fork carriage, push the fork joystick (7) forward.

To tilt the fork carriage (optional) upwards, pull the tilt joystick (8) backwards. To tilt the fork carriage downward, push the tilt joystick (8) forward.

To side shift (optional) the fork carriage to the right, pull the side shift joystick (9) backwards. To side shift the fork carriage to the left, push the side shift joystick (9) forward.

To spread the forks (optional) wider, push the spread joystick (10) forward. To position the forks narrower, pull the spread joystick (10) backwards.

Manually adjusting fork arm position

CAUTION: Ensure that proper care is taken when adjusting the fork arms to prevent crushing damages.

NOTE: Ensure that both forks are equally distant from the truck centre.

Adjusting is made by following the below step:

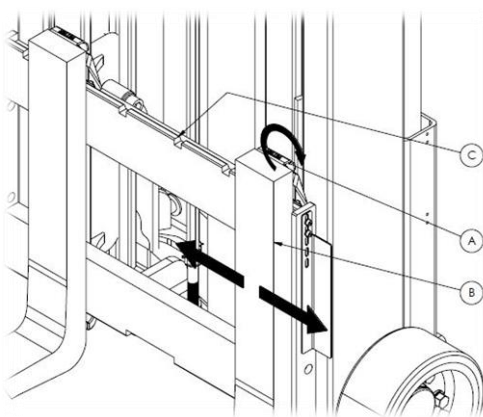

Fig 4.3

- Raise the forks slightly off the ground,
- Raise the quick-release levers (A),
- Push/pull the fork arm (B) to the desired position,

- Fold down the quick-release lever (A) and ensure the fork arm locks into one of the positions in the fork face plate (C).

Parking the truck

DANGER: The truck may never be parked with raised forks and/or load. Risk of fatal injury!

When parking the truck:

- Lower the forks until they touch the ground and tilt the forks forward,
- Turn off the truck with the switch key (or equivalent start/stop system).

This applies the parking brake

CAUTION: If leaving the truck for several days the battery must be disconnected to de-energize all additional components. If this is not made there is a risk of battery discharge.

Driving under load

DANGER: When transporting cargo, the dispatcher must ensure that the goods are safely loaded for transportation and secured as necessary. Please therefore make sure that goods are properly stacked and there is no damage to packaging, pallets etc. The carrier must ensure safe loading.

DANGER: Do not transport loads if they have slipped to the side (e. g. with sideshift).

- Approach the load to be taken up carefully and as accurately as possible,
- If applicable, set the fork carriage to vertical,
- Lift or lower the fork carriage to the necessary height,
- Carefully steer the truck forks beneath the center of the load to be taken up, where possible so the load touches the fork back, taking account of adjacent loads,
- Lift fork carriage until the load is no longer in contact with the supporting surface,
- Reverse the truck to release the load,
- If applicable, tilt the fork carriage backwards,

- Transport the load close to the floor.
- On ascents/descents, always transport loads facing uphill; never travel across the slope or turn around.
- If visibility is poor, instructions should be provided by a second person.
- If the load to be transported is stacked so high as to obstruct visibility in the drive direction, the truck must only be driven in reverse.
- To release the load, follow the above steps in opposite order.

Load backrest (optional)

The truck can be fitted with a removable load backrest.

When handling loads that may be unstable, or if other circumstances demands it, the truck must be fitted with a load backrest.

Contact your retailer or service partner

Emergency lowering

In the event of malfunction of the truck the fork carriage can be manually lowered.

DANGER: Take extreme precautions when opening the valve for manual lowering. The hydraulic pressure from the weight of the fork carriage and cargo can cause the forks to lower uncontrollably.

DANGER: Ensure that no personnel are in the vicinity of the truck when this action is performed. Ensure that the fork carriage, or any cargo on the forks, are not in danger of surrounding objects.

Manual lowering of the fork carriage is performed by following the below steps:

- Remove the panel covering the hydraulic compartment,

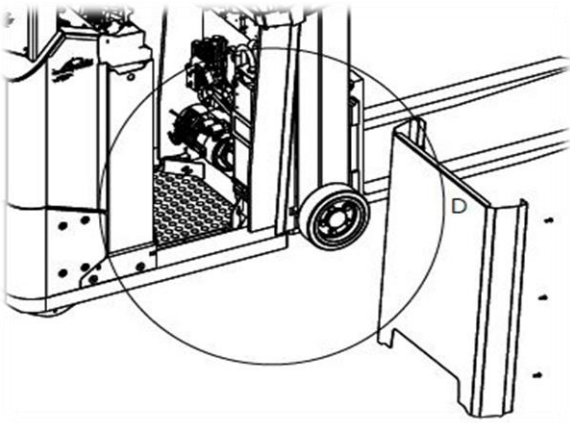

Fig 5.1

- If the truck is equipped with more than one hydraulic function, two additional valves (2Y11 and 2Y2) will be fitted to the hydraulic pump unit. Remove the cap on valve 2Y11.

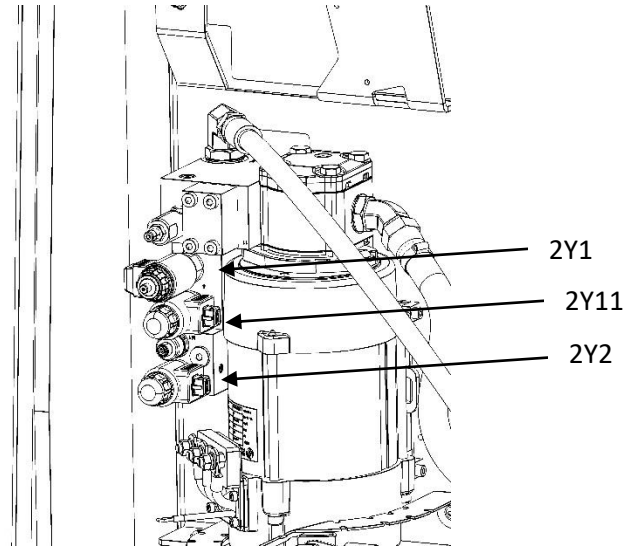

Fig 5.2

- Push and hold the button under the cap on (2Y11)
- To lower the fork carriage, unscrew the brass-knob on valve (2Y1) very slowly and carefully in a controlled manner.
- When the forks are completely lowered to the desired height, screw in the brass knob on (2Y1) and put the cap back if applicable.

Battery

DANGER: The batteries contain corrosive sulphuric acid. Safety glasses, safety gloves and appropriate clothing must therefore be used at all times when working with batteries. If fluid comes into contact with eyes an eye shower must be used and medical treatment sought. On contact with the skin remove the fluid immediately.

The battery must be fully secured in the battery compartment. This prevents the battery from sliding and tipping over during operation. The trucks battery locking mechanism is designed to fit the custom tray of the battery.

DANGER: The truck must not be used with a different battery tray since the locking mechanism can only function securely with the correct tray.

NOTE: The truck is equipped with a sensor ensuring the battery is fixed in position while being under operation. If the battery is not fixed properly the trucks safety system will not allow the truck to be operated.

WARNING: Voltage and battery weight must correspond to the values stated on the machine plate. With insufficient battery weight stability is reduced, and the risk of shifting the center of gravity is increased.

Battery Type

The truck runs on a 24-volt battery. Lead-acid, Gel or Li-Ion batteries can be used in the truck. These battery types are built in different ways, it is therefore critical to use the correct charger intended for each specific type.

CAUTION: If a switch between battery types is made, the producer must be made aware of this. The different battery types use different software setups.

The minimum weight of the battery is stated on the truck's identification plate, located behind the lift mast.

CAUTION: Using the wrong type of charger may damage the battery.

Service and inspection

The battery is easily accessible by folding up the panel above the battery (A). The operator/technician now have full access to the battery for inspection/charging.

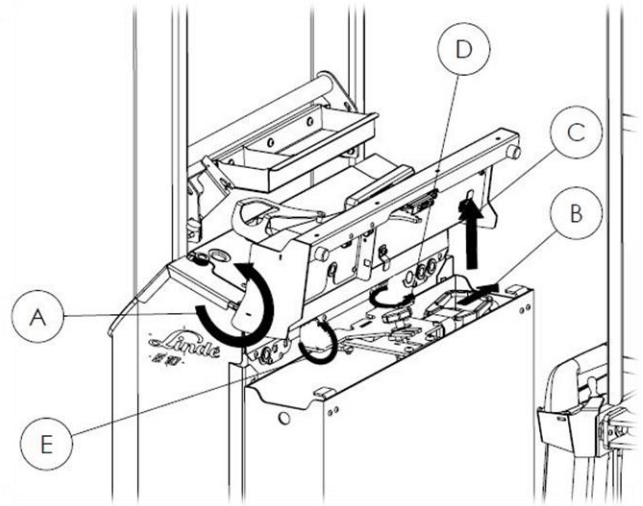

Fig 6.1

The battery is the truck's power source and must be regularly maintained to not lose its power. Therefore, ensure that:

- The battery is kept dry and clean.
- The battery is charged regularly.
- Check the fluid levels in the cells (lead-acid batteries) and refill with distilled water if necessary. The fluid levels should be at approximately 10-15 mm above the cell plates.

Check that battery cables and connections are in good condition.

- Corrosion is prevented by removing oxidation residue from the battery poles and lubricating them with lubricant specially developed for the application.

Measure the acid density of the battery regularly. Check the included handling and operational manual for the battery to ensure the values correspond.

Contact your service partner

Charging the battery

DANGER: No smoking or open flames are permitted near the battery when it is charging. The charging process releases explosive gases, which therefore absolutely requires that the battery charging take place in a well-ventilated area and with the hatches open. Never place metal objects on the battery poles, as short circuiting may occur.

Gel- or Li-Ion batteries can also be charged in other areas.

Contact your service partner

Please see fig 6.1 for below steps.

Before charging

- Turn off the truck,
- Fold up the panel (A) above the battery,
- Disconnect the truck from the battery connector by pulling the handle straight out from the battery connector (B),
- Hang the battery connector on the mount (C),
- Attach the battery charger to the battery connector,
- Start the battery charger,
- Confirm that the charger shows normal readings.

When charging is completed

- Switch the battery charger off and disconnect the battery connector from the charger,
- Re-connect the battery with the truck.

Removing a fixed battery

As standard the truck is delivered with a fixed battery solution. This means that the truck is not prepared for a battery exchange system.

If service or maintenance requires the battery to be removed from the truck, follow these steps:

- Turn off the truck,
- Fold up the panel above the battery compartment (A),

- Disconnect the truck from the battery connector by pulling the handle straight out from the battery connector (B),
- Hang the battery connector on the mount (C),
- Release the locking mechanism from the battery tray by turning the knob counter clockwise (D),
- Fold up the battery locking plate (E),
- Push/pull out the battery onto suitable equipment. The battery is still laterally movable despite the lack of steel rollers.

CAUTION: The battery is heavy, ensure that there is no risk of the battery tipping over. Danger to equipment and/or personal is present. Ensure that the equipment to which the battery is transferred to is of appropriate dimensions considering the weight of the battery.

Contact your service partner

Battery exchange system

The truck can also be fitted with steel rollers (optional). This is recommended if a battery exchange system is used.

The manufacturer of the truck can offer suitable equipment for battery exchange.

Contact your dealership

To exchange the battery, follow these steps:

- Turn off the truck,
- Fold up the panel above the battery compartment (A),
- Disconnect the truck from the battery connector by pulling the handle straight out from the battery connector (B),
- Hang the battery connector on the mount (C),
- Release the locking mechanism from the battery tray by turning the knob counter clockwise (D),
- Fold up the battery locking plate (E),
- Push/pull out the battery onto suitable equipment,
- Push/Pull in the fully charged battery into the truck,

- Fix and connect the battery by following the steps in reversed order.

CAUTION: The battery is heavy, ensure that there is no risk of the battery tipping over. Danger to equipment and/or personal is present. Ensure that the equipment to which the battery is transferred to is of appropriate dimensions considering the weight of the battery.

Electrical interface for external systems

If connection of an external system is needed, this can be done underneath the top-panel on the battery side, above the drive motor. Connection point I labelled “X40” and consists of a Molex Mini-Fit 4P (24V 5A).

No performance level is achieved on the connector.

Warning: Field modification and installation of electrical accessories shall be carried out and documented by trained personal only, and the requirements of this document shall be maintained.

Contact your service partner

Transporting the truck using a lorry

CAUTION: The truck shall only be transported on a closed lorry, well protected from the elements such as rain, snow etc. Serious damage to electronic components may occur if the truck is exposed for rain, snow etc.

CAUTION: The driver is responsible for his means of transport, the transportation safety device and for the transportation of the truck.

Observe the national regulations for your country.

DANGER: Risk to life caused by overloading and material damage!

- Only load the truck if the load capacity of the means of transport, ramps and loading bridges is greater than the total actual weight of the truck.
- Note the loading weight on the nameplate.
- To prevent the truck from tipping over the edge or corners, avoid steering movements on narrow loading bridges/ramps.

Loading/offloading procedures - Lorry

Requirements for loading:

- The loading surface of the transport vehicle must be dry and swept clean.
- The tires on the truck must be clean.
- Before driving across a loading bridge, ensure that the loading bridge is properly attached and secured.
- Ensure that the transport vehicle onto which the truck is to be driven has been sufficiently secured against moving.
- Drive slowly and carefully onto the transport vehicle.
- Lower the lift mast and tilt the fork carriage forwards.

The fork arms must be resting fully on the ground.

- Switch off the truck, parking brake is applied automatically.

- Push the emergency off switch.
- Place and secure wedges underneath the wheels, or drive the truck against a fixed stop so that the truck faces the fixed stop.

Loading/offloading procedures - Crane

The truck is equipped with four lifting points that shall be used when performing a lift with a crane.

DANGER: Ensure that the crane has sufficient capacity to perform a safe lift of the truck. Ensure also that the chains/straps are approved for the weight and are in good condition.

When performing a lift with crane, the crane operator is solely responsible for the safety of the personnel in the direct vicinity and the truck itself.

When lifting with a crane separate chains/straps shall be attached at the trucks lifting points as below.

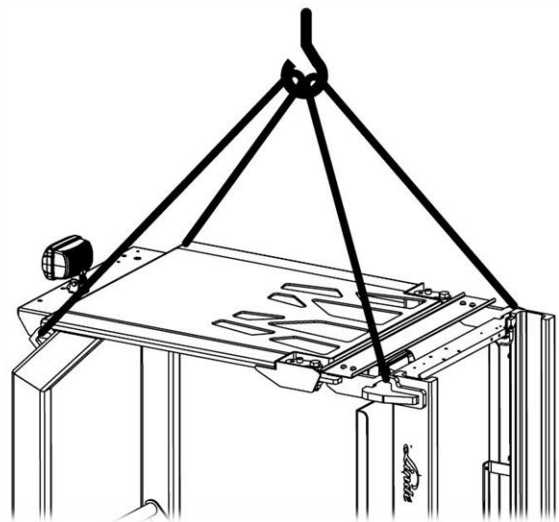

Fig 7.1

Lashing procedures

- The transport vehicle must be equipped with lashing points with a load capacity of at least 2000 daN.
- 50-mm polyester lashing straps with a load capacity of at least 2500 daN must be used to secure the load.

Lash the truck securely on the right-hand and left-hand side. Use edge and surface protection. Ensure that any components such as lights, hose lines etc are not tensioned by the lashing straps.

CAUTION: The responsibility for a secure lashing lies with the transporting company/driver of the lorry. Ensure that the truck is unable to shift/move during transport.

Service

The truck will only remain ready for operation at all times if the servicing and inspection tasks are performed at regular intervals and in accordance with the information in the operating instructions.

Maintenance work may be performed only by competent persons. You can agree to have this work performed on the basis of a service contract concluded with your service partner.

Whenever servicing work is performed, the truck must be parked on a level surface and secured so that it cannot roll away.

The truck must be switched off completely, and the battery male connector and switch key must be removed.

When working with the fork carriage and/or lift mast raised, make sure they are secured against accidental dropping.

Do not make any modifications, in particular attachments or conversions, to your truck without the manufacturer's approval.

Following all servicing work, a function check and test run must be performed on the truck.

Periodic safety inspection

Periodic safety inspections are required in order to maintain the function and security of the truck.

The national regulations must be observed without fail.

In Europe, the national laws are based on the directives 95/63/EC, 99/92/EC and 2001/45/EC. These stipulate that periodic safety inspections of the truck must be carried out by competent personnel, in order to ensure proper condition.

There is a recommendation setting out the scope of the periodic safety inspection —FEM

4.004 of the European Industrial Truck Association—which defines a test log to document the current safety inspection and an inspection sticker for the next safety inspection. The next safety inspection date is shown by the year number (3) on an adhesive label (2), which changes colour every year and is found on a label (1).

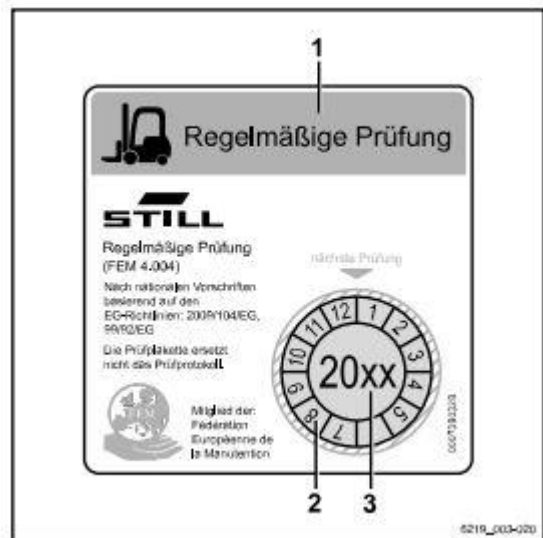

The scope of the testing is added by the manufacturer in accordance with the specific truck type. Please contact your service partner to carry out this work.

Software and parameters

The truck is using a software system supplied by Curtis. In order to perform service and regular maintenance as well as trouble shooting, the appropriate software and dongle for PC/laptop must be available.

Contact your service partner

DANGER: Only approved and competent personnel are authorized to access the trucks software and parameter system. Incorrect use and modification of the trucks parameters can result in damages to the truck or the facility's as well as present great danger to the operator and other personnel.

Modification of the trucks parameters may result in unwanted behaviour.

Any modification of the truck's parameters should always be made in agreement with the manufacturer.

Contact your service partner.

The connecting point for the Curtis controller/PC dongle is located under the foldable battery panel, on the left-hand side of the operator compartment.

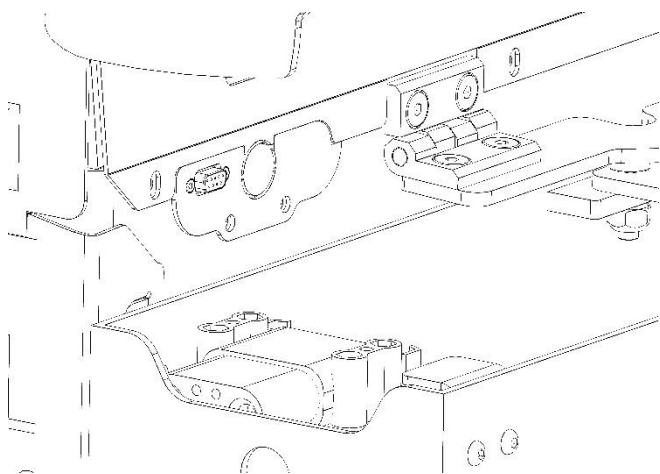

Fig 8.1

NOTE: The parameters and software system are only accessible when the battery is connected and the truck is turned on.

Service intervals

The specified service intervals are subject to the operating conditions and application conditions, as well as the consumables in use. In certain circumstances, the service intervals can be changed. **In all cases, the "Regular Service" must be performed once per year.**

In the case of operation in extreme conditions (e.g. heat, cold or dust), the service intervals must be reduced.

Contact your service partner.

A small service should be done every 500 hours. A major service should be performed every 1000 hours or once a year. The table at page four and onwards

describes the service points and when they should be performed. For more information see the service manual.

Special service point

If the truck is used in an environment where the temperature is less than 5 °C or parking is done in cold, or the truck is subjected to large changes in temperature, then the oil in the gearbox must be changed annually. Preferably in connection with the annual control of forks







On the following pages is the standard service schedule for the truck. This can also be found in the service booklet.

Contact your service partner.

Influence of the service schedule

Certain factors will affect the service life more than others, and just that is specific to each customer and location. To clarify what is required of the client, take help of pictograms below along with the service schedule. Here is stated what is required at each service, and which is required by various additional conditions.

Symbols

-  Service as standard
-  Cold, less than 5 °C or parking in cold
-  High humidity
-  Temperature variations
-  Dusty environment
-  Uneven floors

		500h	Sign	1000h	Sign
1	Chassis				
1.1	Clean	S		S	
1.2	Check for cracks and damage specially on overhead	*5 S		S	
1.3	Re-tighten bolts securing the over head guard	S		S	
1.4	Inspect the load wheels for cracks and other damage	S		S	
1.5	Check the motor cover and locks are not damaged			S	
2	Mast				
2.1	Clean	S		S	
2.2	Check for cracks and damage	S		S	
2.3	Check the fork carriage for cracks and damage	S		S	
2.4	Check the bolt attachment against chassis	S		S	
2.5	Re-tighten bolts securing the centre cylinder	S		S	
2.6	Lubricate all bearings and bushings	S		S	
2.7	Check the mast rollers for damage and wear	S		S	
2.8	Check for abnormal gap between rollers and mast	S		S	
2.9	If applicable, check the initial linkage and if necessary adjust	S		S	
2.10	Check the chain, fixing devices and adjust the tension	S		S	
3	Drive unit				
3.1	Clean	S		S	
3.2	Check the gearbox and wheels for damage or leakage	S		S	
3.3	Re-tighten all bolts			S	
3.4	Gearbox oil change				
3.5	Check the servo gear gap			S	
3.6	Clean drive motor pulse sensor	S		S	
3.7	Check the brake play in released position			S	
4	Hydraulic system				
4.1	Clean	S		S	
4.2	Check for leakage			S	
4.3	Oil change			S	S
4.4	Check oil level in the tank			S	
4.5	Check carbon brushes on pump motor			S	
4.6	Re-tighten bolts on pump motor including wiring				
5	Electrical system				
5.1	Clean	S		S	
5.2	Check wiring for wear and loose connections	S		S	
5.3	Check steering wheel friction	S		S	
5.4	Check the limit switches and if necessary adjust them			S	
5.5	Check the contactor tips			S	
6	Battery				
6.1	Clean, according to battery manufacturer's instructions	S		S	
6.2	Check the battery cables and connections	S		S	
6.3	Check the fluid level and density after charging	S		S	
6.4	Check the battery indicator and if necessary adjust it			S	
6.5	Check the battery locking device for wear and damage	S		S	
7	Castors				
7.1	Clean	S		S	
7.2	Inspect for cracks and other damage	S		S	
7.3	Lubricate all bearings	S		S	
7.4	Re-tighten bolts			S	
8	Operators enviroment				
8.1	Check that all controls are intact	*5 S		S	
8.2	Check protective glass for cracks and loose screws	*5 S		S	
8.3	Check that the machine plate is intact	S		S	
8.4	Perform a function check of all controls	S		S	

		1500h	Sign	2000h	Sign
1	Chassis				
1.1	Clean				
1.2	Check for cracks and damage specially on overhead				
1.3	Re-tighten bolts securing the over head guard				
1.4	Inspect the load wheels for cracks and other damage				
1.5	Check the motor cover and locks are not damaged				
2	Mast				
2.1	Clean				
2.2	Check for cracks and damage				
2.3	Check the fork carriage for cracks and damage				
2.4	Check the bolt attachment against chassis				
2.5	Re-tighten bolts securing the centre cylinder				
2.6	Lubricate all bearings and bushings				
2.7	Check the mast rollers for damage and wear				
2.8	Check for abnormal gap between rollers and mast				
2.9	If applicable, check the initial linkage and if necessary adjust				
2.10	Check the chain, fixing devices and adjust the tension				
3	Drive unit				
3.1	Clean				
3.2	Check the gearbox and wheels for damage or leakage				
3.3	Re-tighten all bolts				
3.4	Gearbox oil change				
3.5	Check the servo gear gap				
3.6	Clean drive motor pulse sensor				
3.7	Check the brake play in released position				
4	Hydraulic system				
4.1	Clean				
4.2	Check for leakage				
4.3	Oil change				
4.4	Check oil level in the tank				
4.5	Check carbon brushes on pump motor				
4.6	Re-tighten bolts on pump motor including wiring				
5	Electrical system				
5.1	Clean				
5.2	Check wiring for wear and loose connections				
5.3	Check steering wheel friction				
5.4	Check the limit switches and if necessary adjust them				
5.5	Check the contactor tips				
6	Battery				
6.1	Clean, according to battery manufacturer's instructions				
6.2	Check the battery cables and connections				
6.3	Check the fluid level and density after charging				
6.4	Check the battery indicator and if necessary adjust it				
6.5	Check the battery locking device for wear and damage				
7	Castors				
7.1	Clean				
7.2	Inspect for cracks and other damage				
7.3	Lubricate all bearings				
7.4	Re-tighten bolts				
8	Operators enviroment				
8.1	Check that all controls are intact				
8.2	Check protective glass for cracks and loose screws				
8.3	Check that the machine plate is intact				
8.4	Perform a function check of all controls				

		2500h	Sign	3000h	Sign
1	Chassis				
1.1	Clean	S		S	
1.2	Check for cracks and damage specially on overhead	*5 S		S	
1.3	Re-tighten bolts securing the over head guard	S		S	
1.4	Inspect the load wheels for cracks and other damage	S		S	
1.5	Check the motor cover and locks are not damaged			S	
2	Mast				
2.1	Clean	S		S	
2.2	Check for cracks and damage	S		S	
2.3	Check the fork carriage for cracks and damage	S		S	
2.4	Check the bolt attachment against chassis	S		S	
2.5	Re-tighten bolts securing the centre cylinder	S		S	
2.6	Lubricate all bearings and bushings	S		S	
2.7	Check the mast rollers for damage and wear	S		S	
2.8	Check for abnormal gap between rollers and mast	S		S	
2.9	If applicable, check the initial linkage and if necessary adjust	S		S	
2.10	Check the chain, fixing devices and adjust the tension	S		S	
3	Drive unit				
3.1	Clean	S		S	
3.2	Check the gearbox and wheels for damage or leakage	S		S	
3.3	Re-tighten all bolts			S	
3.4	Gearbox oil change				
3.5	Check the servo gear gap			S	
3.6	Clean drive motor pulse sensor	S		S	
3.7	Check the brake play in released position			S	
4	Hydraulic system				
4.1	Clean	S		S	
4.2	Check for leakage			S	
4.3	Oil change			S	S
4.4	Check oil level in the tank			S	
4.5	Check carbon brushes on pump motor			S	
4.6	Re-tighten bolts on pump motor including wiring				
5	Electrical system				
5.1	Clean	S		S	
5.2	Check wiring for wear and loose connections	S		S	
5.3	Check steering wheel friction	S		S	
5.4	Check the limit switches and if necessary adjust them			S	
5.5	Check the contactor tips			S	
6	Battery				
6.1	Clean, according to battery manufacturer's instructions	S		S	
6.2	Check the battery cables and connections	S		S	
6.3	Check the fluid level and density after charging	S		S	
6.4	Check the battery indicator and if necessary adjust it			S	
6.5	Check the battery locking device for wear and damage	S		S	
7	Castors				
7.1	Clean	S		S	
7.2	Inspect for cracks and other damage	S		S	
7.3	Lubricate all bearings	S		S	
7.4	Re-tighten bolts			S	
8	Operators enviroment				
8.1	Check that all controls are intact	*5 S		S	
8.2	Check protective glass for cracks and loose screws	*5 S		S	
8.3	Check that the machine plate is intact	S		S	
8.4	Perform a function check of all controls	S		S	

		3500h	Sign	4000h	Sign
1	Chassis				
1.1	Clean				
1.2	Check for cracks and damage specially on overhead				
1.3	Re-tighten bolts securing the over head guard				
1.4	Inspect the load wheels for cracks and other damage				
1.5	Check the motor cover and locks are not damaged				
2	Mast				
2.1	Clean				
2.2	Check for cracks and damage				
2.3	Check the fork carriage for cracks and damage				
2.4	Check the bolt attachment against chassis				
2.5	Re-tighten bolts securing the centre cylinder				
2.6	Lubricate all bearings and bushings				
2.7	Check the mast rollers for damage and wear				
2.8	Check for abnormal gap between rollers and mast				
2.9	If applicable, check the initial linkage and if necessary adjust				
2.10	Check the chain, fixing devices and adjust the tension				
3	Drive unit				
3.1	Clean				
3.2	Check the gearbox and wheels for damage or leakage				
3.3	Re-tighten all bolts				
3.4	Gearbox oil change				
3.5	Check the servo gear gap				
3.6	Clean drive motor pulse sensor				
3.7	Check the brake play in released position				
4	Hydraulic system				
4.1	Clean				
4.2	Check for leakage				
4.3	Oil change				
4.4	Check oil level in the tank				
4.5	Check carbon brushes on pump motor				
4.6	Re-tighten bolts on pump motor including wiring				
5	Electrical system				
5.1	Clean				
5.2	Check wiring for wear and loose connections				
5.3	Check steering wheel friction				
5.4	Check the limit switches and if necessary adjust them				
5.5	Check the contactor tips				
6	Battery				
6.1	Clean, according to battery manufacturer's instructions				
6.2	Check the battery cables and connections				
6.3	Check the fluid level and density after charging				
6.4	Check the battery indicator and if necessary adjust it				
6.5	Check the battery locking device for wear and damage				
7	Castors				
7.1	Clean				
7.2	Inspect for cracks and other damage				
7.3	Lubricate all bearings				
7.4	Re-tighten bolts				
8	Operators enviroment				
8.1	Check that all controls are intact				
8.2	Check protective glass for cracks and loose screws				
8.3	Check that the machine plate is intact				
8.4	Perform a function check of all controls				

		4500h	Sign	5000h	Sign
1	Chassis				
1.1	Clean				
1.2	Check for cracks and damage specially on overhead				
1.3	Re-tighten bolts securing the over head guard				
1.4	Inspect the load wheels for cracks and other damage				
1.5	Check the motor cover and locks are not damaged				
2	Mast				
2.1	Clean				
2.2	Check for cracks and damage				
2.3	Check the fork carriage for cracks and damage				
2.4	Check the bolt attachment against chassis				
2.5	Re-tighten bolts securing the centre cylinder				
2.6	Lubricate all bearings and bushings				
2.7	Check the mast rollers for damage and wear				
2.8	Check for abnormal gap between rollers and mast				
2.9	If applicable, check the initial linkage and if necessary adjust				
2.10	Check the chain, fixing devices and adjust the tension				
3	Drive unit				
3.1	Clean				
3.2	Check the gearbox and wheels for damage or leakage				
3.3	Re-tighten all bolts				
3.4	Gearbox oil change				
3.5	Check the servo gear gap				
3.6	Clean drive motor pulse sensor				
3.7	Check the brake play in released position				
4	Hydraulic system				
4.1	Clean				
4.2	Check for leakage				
4.3	Oil change				
4.4	Check oil level in the tank				
4.5	Check carbon brushes on pump motor				
4.6	Re-tighten bolts on pump motor including wiring				
5	Electrical system				
5.1	Clean				
5.2	Check wiring for wear and loose connections				
5.3	Check steering wheel friction				
5.4	Check the limit switches and if necessary adjust them				
5.5	Check the contactor tips				
6	Battery				
6.1	Clean, according to battery manufacturer's instructions				
6.2	Check the battery cables and connections				
6.3	Check the fluid level and density after charging				
6.4	Check the battery indicator and if necessary adjust it				
6.5	Check the battery locking device for wear and damage				
7	Castors				
7.1	Clean				
7.2	Inspect for cracks and other damage				
7.3	Lubricate all bearings				
7.4	Re-tighten bolts				
8	Operators enviroment				
8.1	Check that all controls are intact				
8.2	Check protective glass for cracks and loose screws				
8.3	Check that the machine plate is intact				
8.4	Perform a function check of all controls				

Changing wheels

DANGER: When changing wheels, the truck must be parked on a level surface and secured so that it cannot roll away.

The truck must be switched off completely, and the battery male connector and switch key must be removed.

In order to change wheels a suitable truck jack. Ensure that the lifting equipment can handle the weight of the truck.

When using a jack, the truck shall only be lifted to the point when the wheels lift from the floor. If lifted to high, the truck is in danger of tipping over.

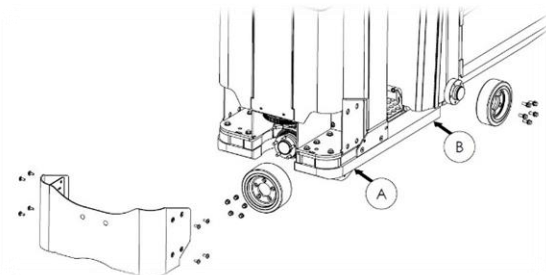

Fig 9.1

To change load wheels, follow these steps:

- Loosen the wheel nuts one full rotation before lifting the truck.
- Place the jack at position (B),
- Lift the truck to the required height,
- Unscrew the bolts holding the load wheel,
- Replace the load wheel and tighten the bolts to the specified torque 140 NM.

To change the drive wheel, follow these steps:

- Remove the fender,
- Place the jack at position (A),
- Lift the truck to the required height,
- Place a wooden block, or similar object, under the truck,
- Lower the jack and perform the same procedure on the equivalent position on the other side of the truck,
- Rotate the gearbox as the photo above,
- Unscrew the bolts holding the drive wheel,
- Replace the drive wheel and tighten the bolts to the required torque 140 NM,
- Lift the truck using the jack to remove the wooden blocks, one side at the time,
- Re-attach the fender, apply new threadlock to the bolts and tighten to the required torque 140 NM

Technical data

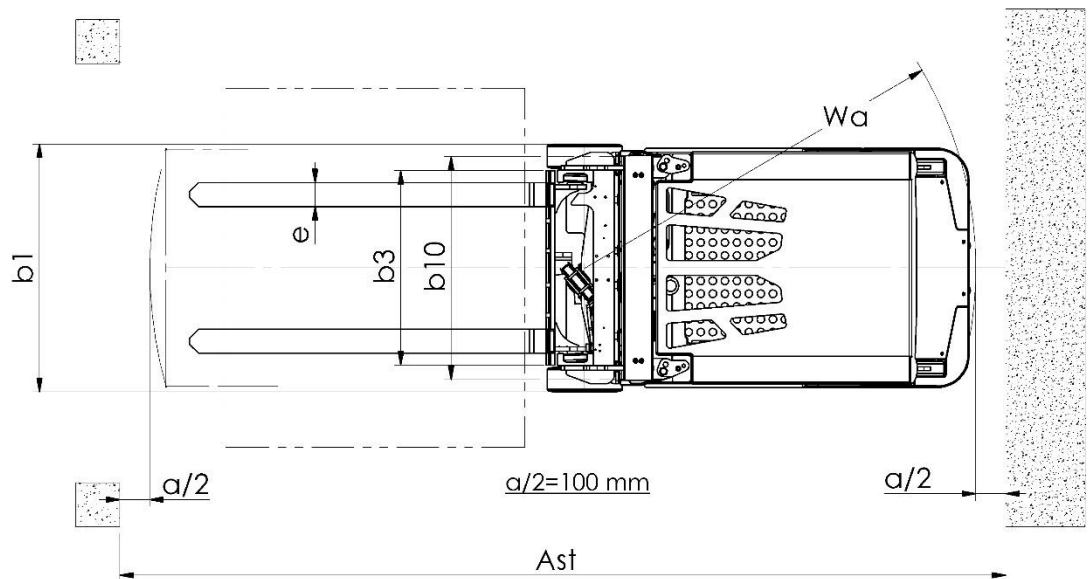
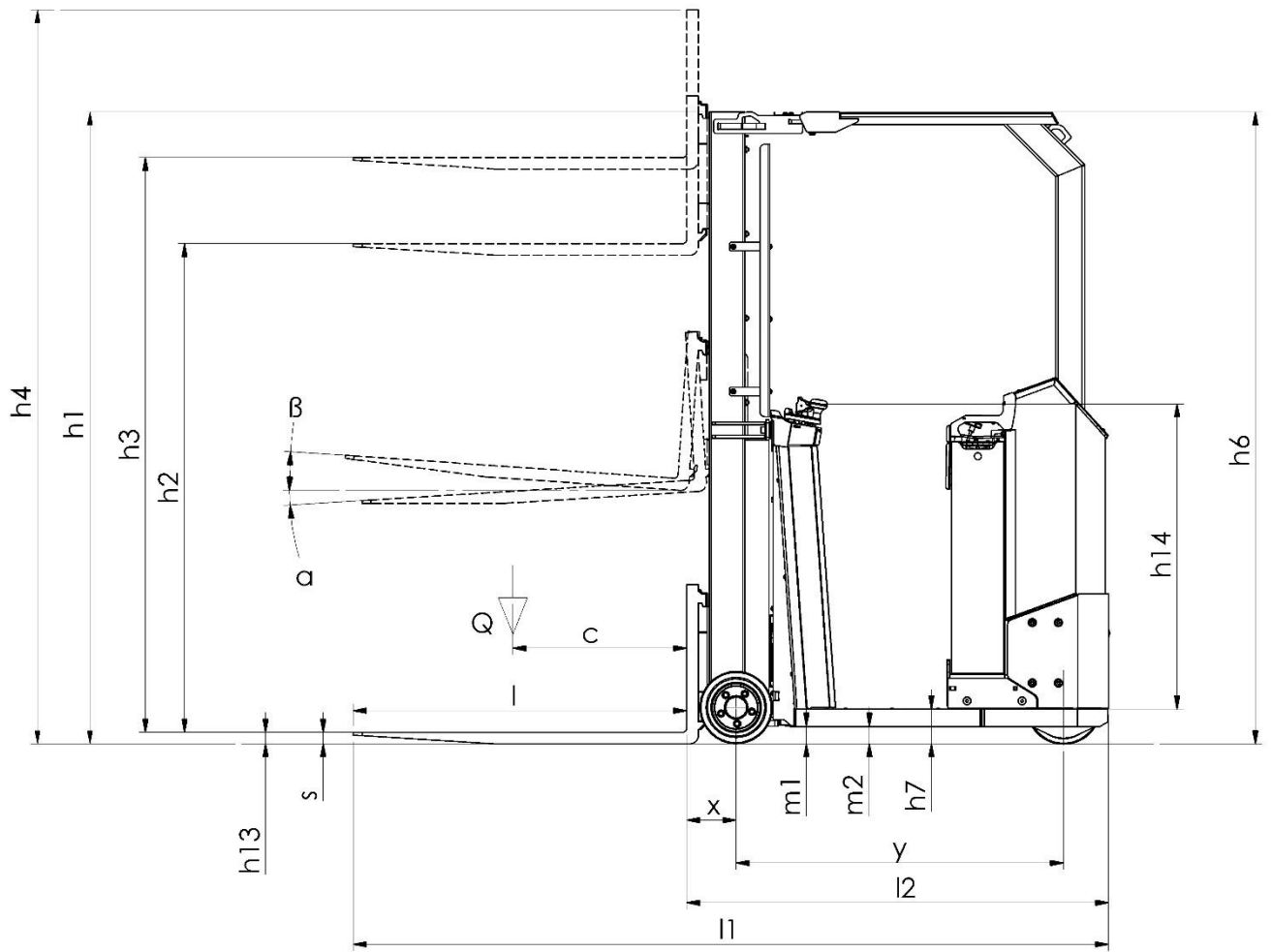

Characteristics	1.1	Manufacturer		Actil	Actil	Actil
	1.2	Model designation		SXV Simplex	SXV Duplex	SXV Triplex
	1.3	Power unit		Battery	Battery	Battery
	1.4	Operation		Stand-on	Stand-on	Stand-on
	1.5	Load capacity	Q (t)	1,0	1,0	1,0
	1.6	Load center	c (mm)	600	600	600
	1.8	Axle centre to fork face	x (mm)	170 ¹⁾	170 ¹⁾	151 ¹⁾
	1.9	Wheelbase	y (mm)	1129	1129	1145
	Weights	2.1	Service weight	(kg)	2238 ²⁾	2410 ²⁾
2.2		Axle load with load, drive side/load side	(kg)	820/2418 ²⁾	712/2698 ²⁾	910/2680 ²⁾
2.3		Axle load without load, drive side/load side	(kg)	1501/737 ²⁾	1507/903 ²⁾	1560/1030 ²⁾
Wheels/tyres	3.1	Tyres		Tractothan	Tractothan	Tractothan
	3.2	Tyre size, drive side		Ø254x115	Ø254x115	Ø254x115
	3.3	Tyre size, load side		2xØ254x82	2xØ254x82	2xØ254x82
	3.5	Wheels, number drive side/load side (x=driven wheels)		1x/2	1x/2	1x/2
	3.7	Track width, load side	b10 (mm)	746	746	746
Dimensions	4.1	Fork carriage tilt, up/down	a/B Grad	4/2 ³⁾	4/2 ³⁾	4/2 ³⁾
	4.2	Height of mast, lowered	h1 (mm)	2190 (1990)	2190 (1990)	2190 (1990)
	4.3	Free lift	h2 (mm)	1630 (1430) ⁵⁾	1630 (1430) ⁵⁾	1630 (1430) ⁵⁾
	4.4	Lift	h3 (mm)	1660 (1460)	3210 (2810)	4780 (4180)
	4.5	Height of mast, extended	h4 (mm)	2250 (2050) ⁶⁾	3870 (3470) ⁶⁾	5440 (4840) ⁶⁾
	4.7	Height of overhead guard	h6 (mm)	2190 (1995)	2190 (1995)	2190 (1995)
	4.8	Stand height	h7 (mm)	120 (85)	120 (85)	120 (85)
	4.9	Height of steering wheel in operating position.	h14 (mm)	1052	1052	1052
	4.15	Fork height, lowered	h13 (mm)	50	50	50
	4.19	Overall length	l1 (mm)	2604 ¹⁾	2604 ¹⁾	2604 ¹⁾
	4.20	Length to fork face	l2 (mm)	1454 ¹⁾	1454 ¹⁾	1454 ¹⁾
	4.21	Overall width	b1 (mm)	828	828	828
	4.22	Fork dimensions	s/e/l (mm)	40/80/1150 ⁴⁾	40/80/1150 ⁴⁾	40/80/1150 ⁴⁾
	4.23	Fork carriage to ISO 2328, class/type.		2A ⁷⁾	2A ⁷⁾	2A ⁷⁾
	4.24	Fork-carriage width	b3 (mm)	650 ⁸⁾	650 ⁸⁾	650 ⁸⁾
	4.31	Ground clearance, mast	m1 (mm)	60	60	60
	4.32	Ground clearance, centre of wheelbase.	m2 (mm)	60	60	60
	4.33	Aisle width with pallet 1000x1200 crosswise	Ast (mm)	2865 ¹⁾	2865 ¹⁾	2865 ¹⁾
	4.34	Aisle width with pallet 800x1200 lengthways	Ast (mm)	2948 ¹⁾	2948 ¹⁾	2948 ¹⁾
	4.35	Turning radius	Wa (mm)	1320	1320	1333
4.39	Aisle width without pallet	Ast (mm)	2865 ¹⁾	2865 ¹⁾	2865 ¹⁾	
Performance	5.1	Travel speed, with/without load	(km/h)	8/12	8/12	8/12
	5.2	Lifting speed, with/without load	(m/s)	0,25/0,42	0,25/0,42	0,21/0,43
	5.3	Lowering speed, with/without load	(m/s)	0,25/0,22	0,25/0,22	0,44/0,32
	5.8	Maximum climbing ability, with/without load	(%)	8/15	8/15	8/15
	5.10	Service brake		Electric	Electric	Electric
Drive	6.1	Drive motor S2 60 minute rating	(kW)	3,0	3,0	3,0
	6.2	Lift motor rating at S3 15%	(kW)	5,7	5,7	5,7
	6.4	Battery voltage/rated capacity (5h)	(V/Ah)	24/300	24/300	24/300
	6.5	Battery weight (±5%)	(kg)	Min 230	Min 230	Min 230
	Others	8.1	Type of drive control		Electronic	Electronic
8.4		Noise level at operator's ear	(dB(A))	<70	<70	<70

- 1) +48mm with optional fork tilting, side shift or spread unit.
- 2) Alternative lift height and options gives different values.
- 3) With optional tilting fork carriage unit.
- 4) With optional combined fork tilt & side shift & spread unit.40/100/1150
- 5) -100 mm with optional fork tilting, side shift or spread unit.
- 6) +100 mm with optional fork tilting, side shift or spread unit.

- 7) Not used in optional combined fork tilt & side shift & spread unit.
 - 8) 800 mm with optional fork tilting, side shift or spread unit.
- Alternative mast types, tyres, equipment, etc. could result in different values. See mast and equipment list.
All technical data according to VDI. 2198.
Performance and dimensions are displayed with reservation for tolerance

Mast data

Simplex		Lift Height h3+h13	Free lift h2	Lift h3	Height of mast lowered h1	Height of mast extended h4	Fork thickness	Fork height, lowered h13	Load capacity to max lift height
	C	1510	1430	1460	1990	2050	40	50	1000
	1710	1630	1660	2190	2250	40	50	1000	
Duplex	C	2860	1430	2810	1990	3470	40	50	1000
		3260	1630	3210	2190	3870	40	50	1000
		3660	1860	3610	2390	4270	40	50	1000
Triplex	C	4230	1430	4180	1990	4840	40	50	1000
		4830	1630	4780	2190	5440	40	50	1000
		5430	1860	5380	2390	6040	40	50	1000

C = Container version with maximum build height 2000 mm

*Technical specification for simplex and triplex will be updated latest Q3 2020

Fluids and consumables

For all fluids and consumables in the truck it is recommended to use the original type. It is also approved to use a fluid or consumable that match the original fluid and/or consumable specification.

Hydraulic oil for standard application	Q8 Heller 32, ISO VG 32
Hydraulic oil for cold store application	Q8 Heller 46, ISO VG 46
Gearbox oil	Q8 T 65 75W-90, SAE 75W90
Grease, mast beams and load wheels	Q8 Rembrandt EP 2 HQ, NLGI 2
Chain spray for leaf chains	Standard chain spray lubricant A167
Screw-locking compound	Fast drying compound – blue

Error codes and trouble shooting

In the event of failure on the truck, an error code will be displayed on the compartment display. The following sections describe the error codes and procedures connected to it.

The truck is using a software system supplied by Curtis. In order to perform service and regular maintenance as well as trouble shooting, the appropriate software and dongle for PC/laptop must be available.

Contact your service partner

Abbreviations

Acronyms	Abbreviations
EPS	Electric power steering
SWS	Steering wheel sensor
HPD	High pedal disable
CAN	Controller area network
VCL	Vehicle control language
KSI	Key Switch Input

Error codes in the display

System Fault (A)

Error code	Description	Possible Cause	Clear fault
A10	Emergency stop	Normally open circuit of E-stop is closed	Release E-stop. Check for short circuit. Cycle KSI.
A13	Alarm Battery safety sensor	Sensor for battery lock is off	Close battery cover. Check sensor
A16	Alarm for servo or CAN Com problems.	No response from EPS on CAN-bus	Check power to EPS or CAN-bus cables. Check power steer error log
A22	Failure of Curtis 1356P node 19 or CAN Communication	No response from Curtis 1356P on CAN-bus at start-up	Check power to module or CAN-bus cables
A23	Failure of Curtis pump module Node 12 or CAN Communication	No response from Curtis 1232SE pump unit on CAN-bus at start-up	Check power to module or CAN-bus cables
A33	Failure of the drive joystick on mast side	Mast side joystick voltage is outside deadband at start up or direction switch is not on	Bring voltage level within deadband parameters. Check connections. Replace joystick
A34	Failure of the drive Joystick on battery side	Battery side joystick voltage is outside deadband at start up or direction switch is not on	Bring voltage level within deadband parameters.

			Check connections. Replace joystick
A41	First stage sensor failure	Top sensor is active when speed reduction is not active	Check first stage sensor. Check reading distance.
A56	Hydraulic HPD Error	Multiple hydraulic inputs active at the same time, or when truck is not interlocked.	Check hydraulic inputs. Check interlock input
A57	Failure of the primary lift Joystick	Joystick voltage is outside deadband at start-up	Check power supply for joystick. Check input voltage and parameter settings. Replace joystick
A58	Failure on the tilt lift Joystick	Joystick voltage is outside deadband at start-up	Check power supply for joystick. Check input voltage and parameter settings. Replace joystick
A59	Failure on the side shift joystick	Joystick voltage is outside deadband at start-up	Check power supply for joystick. Check input voltage and parameter settings. Replace joystick

Li-ion Battery Fault (L)

SIGNAL, Event recording. No alarm. No effect, may be ignored by truck

WARNING, Event recording. No effect may be ignored by truck

ALARM, High Severity. Battery required a derating of truck performance

FAULT, High severity, the truck must be stopped. Battery disconnection procedure started

CRITICAL, Highest severity, the battery must be disconnected immediately

Error Code	(hex code) Type	Meaning
L01	(2113) ALARM	Over Current1 (DISCHARGE OVER CURRENT)
L02	(2114) FAULT	Over Current1 (DISCHARGE OVER CURRENT)
L03	(2115) CRITICAL	Over Current1 (DISCHARGE OVER CURRENT)
L04	(2213) ALARM	OverMeanCurrent (OVER MEAN CURRENT)
L05	(2214) FAULT	OverMeanCurrent (OVER MEAN CURRENT)
L06	(2313) ALARM	Over Current2 (REGENERATIVE OVER CURRENT)
L07	(2314) FAULT	Over Current2 (REGENERATIVE OVER CURRENT)
L08	(2315) CRITICAL	Over Current2 (REGENERATIVE OVER CURRENT)
L09	(2323) ALARM	Over Current3 (CHARGING OVER CURRENT)
L10	(2324) FAULT	Over Current3 (CHARGING OVER CURRENT)
L11	(2325) CRITICAL	Over Current3 (CHARGING OVER CURRENT)
L12	(2333) ALARM	Over Current4 (IMPROPER CHARGING)
L13	(2334) FAULT	Over Current4 (IMPROPER CHARGING)
L14	(3213) ALARM	Over Voltage (CELL OVER VOLTAGE)
L15	(3214) FAULT	Over Voltage (CELL OVER VOLTAGE)
L16	(3215) CRITICAL	Over Voltage (CELL OVER VOLTAGE)

L17	(3223) ALARM	Under Voltage (CELL UNDER VOLTAGE)
L18	(3224) FAULT	Over Voltage (CELL OVER VOLTAGE)
L19	(3225) CRITICAL	Over Voltage (CELL OVER VOLTAGE)
L20	(4212) WARNING	OverTemp1 (CELL OVER TEMPERATURE)
L21	(4213) ALARM	OverTemp1 (CELL OVER TEMPERATURE)
L22	(4214) FAULT	OverTemp1 (CELL OVER TEMPERATURE)
L23	(4222) WARNING	UnderTemp1 (CELL UNDER TEMPERATURE)
L24	(4223) ALARM	UnderTemp1 (CELL UNDER TEMPERATURE)
L25	(4224) FAULT	UnderTemp1 (CELL UNDER TEMPERATURE)
L26	(4232) WARNING	OverTemp2 (BMS OVER TEMPERATURE)
L27	(4233) ALARM	OverTemp2 (BMS OVER TEMPERATURE)
L28	(4234) FAULT	OverTemp2 (BMS OVER TEMPERATURE)
L29	(4242) WARNING	UnderTemp2 (ERROR LOW TEMPERATURE CHARGING AH)
L30	(4243) ALARM	UnderTemp2 (ERROR LOW TEMPERATURE CHARGING AH)
L31	(4244) FAULT	UnderTemp2 (ERROR LOW TEMPERATURE CHARGING AH)
L32	(5104) FAULT	HWFail4 (FUSE BURNED)
L33	(5114) FAULT	HWFail5 (ERROR_SAFESLAVE)
L34	(5204) FAULT	HW fail 1 (ERROR_CURRENTSENSOR)
L35	(5213) ALARM	HW fail 2 (ERROR_TEMPSENSOR)
L36	(5214) FAULT	HW fail 2 (ERROR_TEMPSENSOR)
L37	(5304) FAULT	HW fail 3 (MAIN CONTACTOR MISMATCH)
L38	(5314) FAULT	HW fail 6 (ADD CONTACTOR MISMATCH)
L39	(5704) FAULT	ELECTRONICS (HW ERROR ADC CELL)
L40	(6201) SIGNAL	LOW SOC
L41	(6202) WARNING	LOW SOC
L42	(6203) ALARM	LOW SOC
L43	(6204) FAULT	LOW SOC
L44	(8112) WARNING	CAN Communication (Lost INTERNAL with SLAVEs)

Power Steer Fault (P)

Power steer error codes will show up with prefix P in the display followed by error code. They will also show up in in 1314 PC programming station, see instruction below.

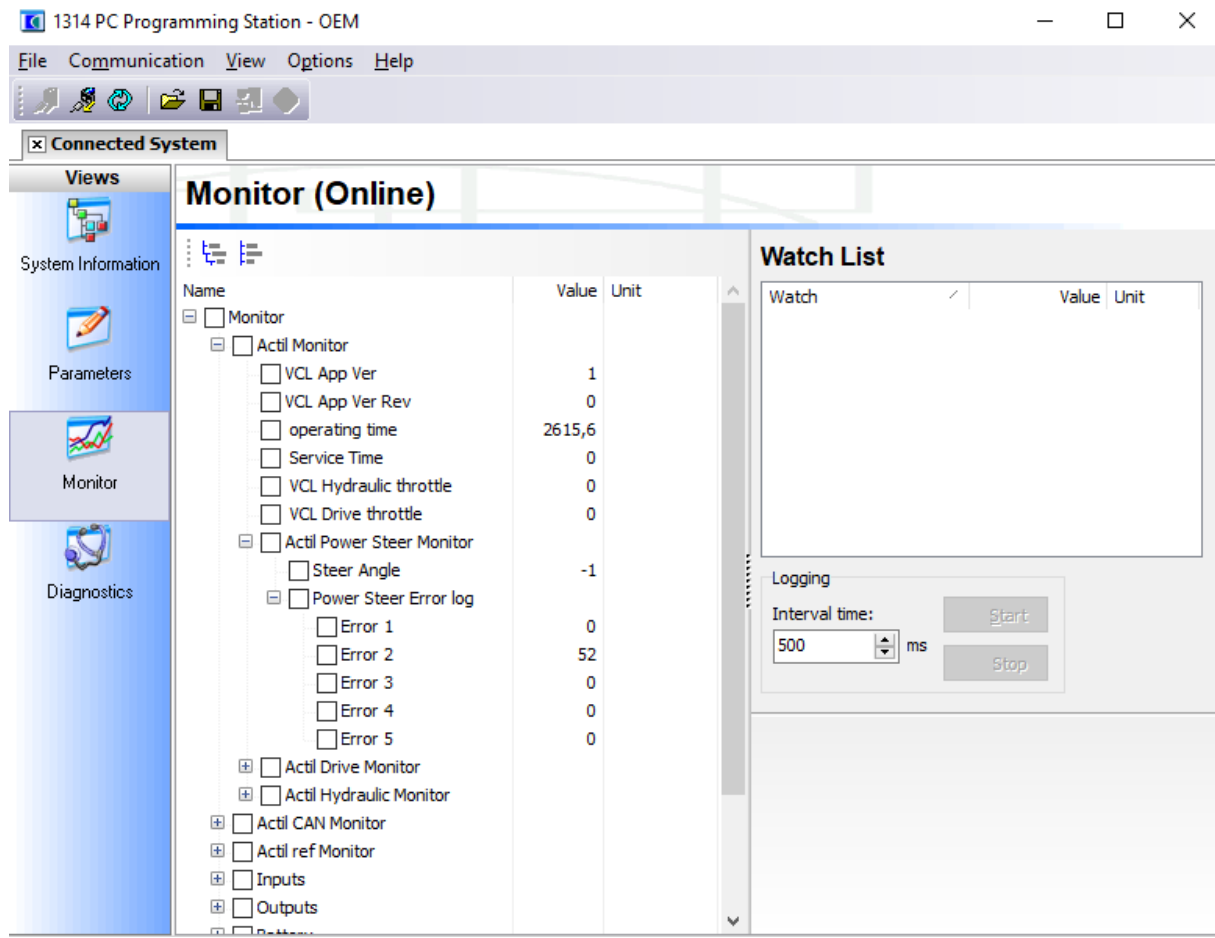

Error code	Operation	Description	Action in field
P00	Curtis has no communication with EPS	No/lost communication on CAN bus with EPS	Check connections
P01	SM Drive Overvolt	The battery voltage reading is above the voltage warning level	Check battery
P02	SM Drive Undervolt	The battery voltage reading is below the voltage warning level	Charge battery
P04	SM Drive Temperature Earning 1	The drive temperature 2 reading is above the temperature 2 warning level	EPS is loaded heavily, inform operator to drive truck smoother.
P06	Time Out from Curtis drive	No/lost communication on CAN bus with Curtis	Check connections
P08	Motor Phasing Calibration Warning	Indicates a motor calibration (phasing) is corrupt; enable check	N/A, Application setup problem.

P09	SWS 1CH Warning	Indicates the SWS has been commanded to operate in single channel mode	SWS2 is out of order and truck is possible to steer on one channel. If repeated, replace SWS.
P10	SWS missing both cannels	If no data is received 50 times in a row. (No data on both channels) This corresponds to 25ms	Broken SWS or problem with cable.
P13	SWS Channel Angle Comparison	This limit corresponds to 20 deg. If the counter of no of times exceeding this limit becomes above 50. This corresponds to 25ms. (A value within valid range will decrease this counter if it is above 0)	Broken SWS or problem with cable.
P15	SWS 2 Arctan conversion	This condition is when the validation of the amplitude fails. (Amplitude out of range) One single failure gives this error code.	Broken SWS, problem with cable or low battery voltage.
P17	SWS2 Loss or Stuck signal	This condition is: No change in SWS Period OR Period is incorrect. If invalid 100 times in a row this event is set. (One correct period reading clears the counter) This corresponds to 10ms	Broken SWS or problem with cable.
P19	SWS missing one channel	If only data for one channel is received 50 times in a row. This corresponds to 25ms	Broken SWS or problem with cable.
P21	Phasing Config (0x03000001 in 48V)	Indicates a missing or corrupt phasing configuration; initialisation check	N/A, Application setup problem.
P22	Phasing Cal Timeout (0x03000002 in 48V)	Indicates that timeout has occurred during phasing	N/A, Application setup problem.
P25	OP Control Config	Indicates a missing or corrupt mode availability configuration	N/A, Application setup problem.
P26	Program Controller State Error	N/A	N/A
P30	Motor Phasing Calibration	Indicates a motor calibration (phasing) is corrupt; enable check	N/A, Application setup problem.
P31	BLAC Config	Indicates a missing or corrupt BLAC configuration; initialisation check	N/A, Application setup problem.
P32	SVPWM Sector	Indicates an error in the SVPWM conversion	N/A, Application setup problem.
P33	BLAC SW Over Current U	Indicates an error in the current control of motor Phase U	The EPS uses too much torque when steering. Single error is normal if steering wheel is locked. If recurring error, check steer gear or replace EPS.

P34	BLAC SW Over Current V	Indicates an error in the current control of motor Phase V	The EPS uses too much torque when steering. Single error is normal if steering wheel is locked. If recurring error, check steer gear or replace EPS.
P35	Pos Loop Endlimit Config	Indicates a missing or corrupt Steering Limit configuration; initialisation check	N/A, Application setup problem.
P36	Pos Loop Contro Config	Indicates a missing or corrupt Position Loop configuration; initialisation check	N/A, Application setup problem.
P37	Speed Loop Endlimit Config	Indicates a missing or corrupt Speed Demand configuration; initialisation check	N/A, Application setup problem.
P38	MX Speed Loop Endlimit Config	Indicates a missing or corrupt Speed Control Loop configuration; initialisation check	N/A, Application setup problem.
P39	Motor not calibrated	Indicates the motor calibration (phasing) is missing; enable check	N/A, Application setup problem.
P41	Sreer Demand Ratio Config	Indicates a missing or corrupt Steer Ratio configuration; initialisation check	N/A, Application setup problem.
P42	Steer Demand SWS Config	Indicates a missing or corrupt Steering SWS Speed Ration configuration; initialisation check	N/A, Application setup problem.
P43	Steer Demand Speed Config	Indicates a missing or corrupt Steering Vehicle Speed Ratio configuration; initialisation check,	N/A, Application setup problem.
P46	Pos error Demand and Encoder correlation	The position demand deviation checks are invalid	The steered wheel has problem following the steering wheel speed. Either the steered wheel is heavy to move or the steering ratio is set too high. If repeated after above checks, replace EPS.
P47	Demand Deviation Config	The position demand configuration parameters are invalid	N/A, Application setup problem.
P48	Reference Switch Deviation Config	The deviation checks configuration parameters are invalid	N/A, Application setup problem.
P51	SM Drive Overvolt	The battery voltage reading is above the voltage error level	Check battery
P52	SM Drive Undervolt	The battery voltage reading is below the voltage error level	Charge battery
P53	SM HW Over Current		
P54	SM Drive Over Temp 1	The drive temperature 2 reading is above the temperature 2 error level	EPS has been loaded heavily and needs to be stationary to cool down.

P60	Can Config	Identifies an error in the CAN configuration files	N/A, Application setup problem.
P61	Gearbox Config	Indicates a missing or corrupt gearbox configuration	N/A, Application setup problem.
P62	CAN_RSRDO_ERROR		
P63	Final Gear Config	Indicates a missing or corrupt final gear configuration; initialisation check	N/A, Application setup problem.
P65	HSO Config Error	N/A	N/A
P71	Home Switch Config	Indicates a missing or corrupt homing STUD configuration; initialisation check	N/A, Application setup problem.
P72	Home Switch CW Timeout	Indicates that timeout has occurred during homing STUD	The stud cannot be found during homing. Check if homing sensor is functional or if homing stud is mounted.
P73	Home Switch CCW Timeout	Indicates that timeout has occurred during homing STUD	The stud cannot be found during homing. Check if homing sensor is functional or if homing stud is mounted.
P74	Home Switch Max Stud Timeout	Indicates that timeout has occurred during homing STUD, Homing Switch is high longer than the max allowed High STUD parameter.	The stud cannot be found during homing. Check if homing sensor is functional or if homing stud is mounted.
P75	Home Switch Min Stud Timeout	Indicates that timeout has occurred during homing STUD, Homing Switch is low longer than the max allowed Low STUD parameter.	The stud cannot be found during homing. Check if homing sensor is functional or if homing stud is mounted.
P77	Configblock Internal CRC Error	Indicates a missing or corrupt Internal configuration; start-up check	N/A, Application setup problem.
P78	Configblock Customer CRC Error	Indicates a missing or corrupt Customer configuration; start-up check	N/A, Application setup problem.
P81	Motor Config	Indicates a missing or corrupt motor configuration; initialisation check	N/A, Application setup problem.
P82	Motor Enc1 No Datat	Indicates a missing or corrupt data reads of motor encoder 1	Internal EPS error. If recurring error, replace EPS.
P83	Motor Enc2 No Datat	Indicates a missing or corrupt data reads of motor encoder 2	Internal EPS error. If recurring error, replace EPS.
P86	DD Invalid Data Tag	Trying to write to an undefined position. This will normally never happen, used only for debug, when adding new contents to storage.	N/A, Application setup problem.

P91	SWS1 Arctan Conversation	This condition is when the validation of the amplitude fails. (Amplitude out of range). One single failure gives this error code.	Broken SWS, problem with cable or low battery voltage.
P93	SWS1 Loss or Stack Signal	This condition is: No change in SWS Period OR Period is incorrect. If invalid 100 times in a row this event is set. (One correct period reading clears the counter) This corresponds to 10ms	Broken SWS or problem with cable. (or low battery voltage)

Curtis Fault (C/d)

Curtis Error codes will show up with **prefix C** for motor controller or **prefix d** for pump controller in the display followed by error code. They will also show up in the diagnostics in 1314 PC programming station.

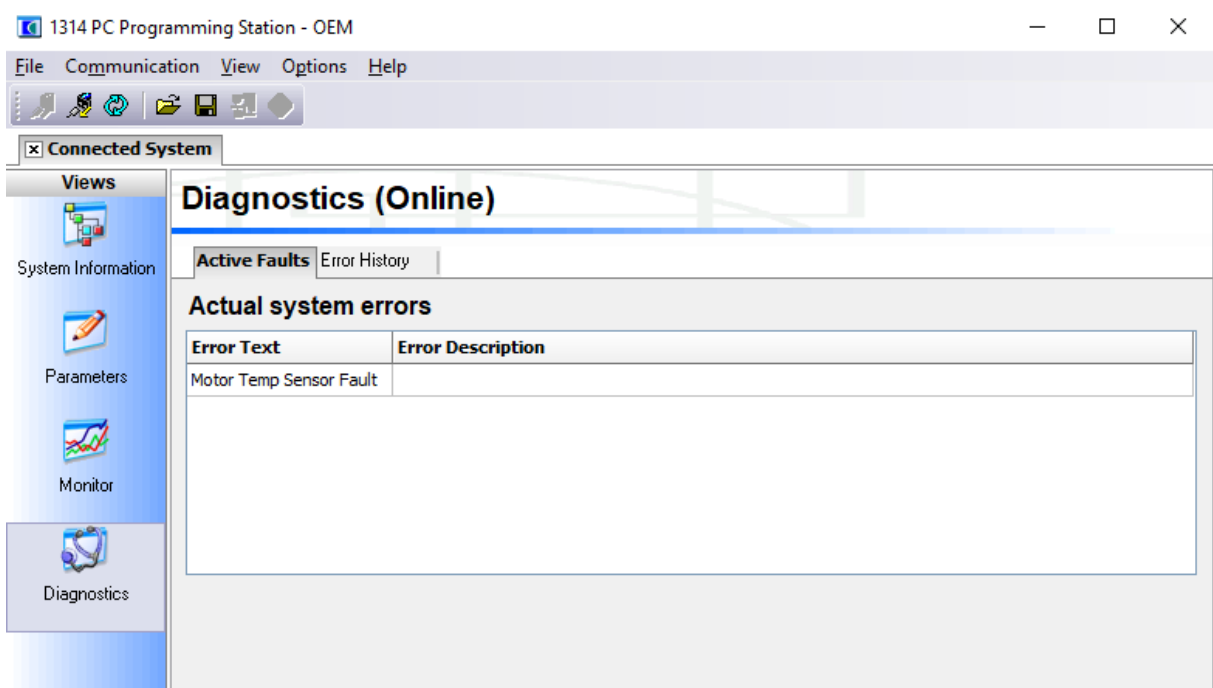

The following error code list is supplied by Curtis Instruments.

CODE	PROGRAMMER LCD DISPLAY EFFECT OF FAULT	POSSIBLE CAUSE	SET/CLEAR CONDITIONS
12	Controller Overcurrent <i>ShutdownMotor;</i> <i>ShutdownMainContactor;</i> <i>ShutdownEMBrake;</i> <i>ShutdownThrottle;</i> <i>FullBrake.</i>	<ol style="list-style-type: none"> External short of phase U,V, or W motor connections. Motor parameters are mis-tuned. Controller defective. Speed encoder noise problems. 	<i>Set:</i> Phase current exceeded the current measurement limit. <i>Clear:</i> Cycle KSI.
13	Current Sensor Fault <i>ShutdownMotor;</i> <i>ShutdownMainContactor;</i> <i>ShutdownEMBrake;</i> <i>ShutdownThrottle;</i> <i>FullBrake.</i>	<ol style="list-style-type: none"> Leakage to vehicle frame from phase U, V, or W (short in motor stator). Controller defective. 	<i>Set:</i> Controller current sensors have invalid offset reading. <i>Clear:</i> Cycle KSI.
14	Precharge Failed <i>ShutdownMotor;</i> <i>ShutdownMainContactor;</i> <i>ShutdownEMBrake;</i> <i>ShutdownThrottle;</i> <i>FullBrake.</i>	<ol style="list-style-type: none"> See Monitor menu » Battery: Capacitor Voltage. External load on capacitor bank (B+ connection terminal) that prevents the capacitor bank from charging. 	<i>Set:</i> Precharge failed to charge the capacitor bank to the KSI voltage. <i>Clear:</i> Cycle Interlock input or use VCL function <i>Enable_Precharge()</i> .
15	Controller Severe Undertemp <i>ShutdownMotor;</i> <i>ShutdownMainContactor;</i> <i>ShutdownEMBrake;</i> <i>ShutdownThrottle;</i> <i>FullBrake.</i>	<ol style="list-style-type: none"> See Monitor menu » Controller: Temperature. Controller is operating in an extreme environment. 	<i>Set:</i> Heatsink temperature below -40°C. <i>Clear:</i> Bring heatsink temperature above -40°C, and cycle interlock or KSI.
16	Controller Severe Overtemp <i>ShutdownMotor;</i> <i>ShutdownMainContactor;</i> <i>ShutdownEMBrake;</i> <i>ShutdownThrottle;</i> <i>FullBrake.</i>	<ol style="list-style-type: none"> See Monitor menu » Controller: Temperature. Controller is operating in an extreme environment. Excessive load on vehicle. 	<i>Set:</i> Heatsink temperature above +95°C. <i>Clear:</i> Bring heatsink temperature below +95°C, and cycle interlock or KSI.
17	Severe B+ Undervoltage <i>Reduced drive torque.</i>	<ol style="list-style-type: none"> See Monitor menu » Battery: Keyswitch Voltage. Non-controller system drain on battery/KSI circuit wiring. KSI disconnected while driving. Blown KSI fuse. 	<i>Set:</i> When below Brownout Voltage for 2 seconds (see Table D-1). <i>Clear:</i> Bring KSI voltage above Brownout Voltage.
17	Severe KSI Undervoltage <i>No Action.</i>	<ol style="list-style-type: none"> See Monitor menu » Battery: Keyswitch Voltage. Non-controller system drain on battery/KSI circuit wiring. KSI disconnected while driving. Blown KSI fuse. 	<i>Set:</i> When below Brownout Voltage for 2 seconds (see Table D-1). <i>Clear:</i> Bring KSI voltage above Brownout Voltage.

CODE	PROGRAMMER LCD DISPLAY EFFECT OF FAULT	POSSIBLE CAUSE	SET/CLEAR CONDITIONS
18	Severe B+ Overvoltage <i>ShutdownMotor;</i> <i>ShutdownMainContactor;</i> <i>ShutdownEMBrake;</i> <i>ShutdownThrottle;</i> <i>FullBrake.</i>	<ol style="list-style-type: none"> 1. See Monitor menu >> Battery: Capacitor Voltage. 2. Battery menu parameters are misadjusted. 3. Battery resistance too high for given regen current. 4. Battery disconnected while regen braking. 	<p><i>Set:</i> Capacitor bank voltage exceeded the Severe Overvoltage limit (see page 58) with FET bridge enabled.</p> <p><i>Clear:</i> Bring capacitor voltage below Severe Overvoltage limit, and then cycle KSI.</p>
22	Controller Overtemp Cutback <i>Reduced drive and brake torque.</i>	<ol style="list-style-type: none"> 1. See Monitor menu >> Controller: Temperature. 2. Controller is performance-limited at this temperature. 3. Controller is operating in an extreme environment. 4. Excessive load on vehicle. 5. Improper mounting of controller. 	<p><i>Set:</i> Heatsink temperature exceeded 85°C.</p> <p><i>Clear:</i> Bring heatsink temperature below 85°C.</p>
23	B+ Undervoltage Cutback <i>Reduced drive torque.</i>	<ol style="list-style-type: none"> 1. Normal operation. Fault shows that the batteries need recharging. Controller is performance limited at this voltage. 2. Battery parameters are misadjusted. 3. Non-controller system drain on battery. 4. Battery resistance too high. 5. Battery disconnected while driving. 6. See Monitor menu >> Battery: Capacitor Voltage. 7. Blown B+ fuse or main contactor did not close. 	<p><i>Set:</i> Capacitor bank voltage dropped below the Undervoltage limit (see page 58) with the FET bridge enabled.</p> <p><i>Clear:</i> Bring capacitor voltage above the Undervoltage limit.</p>
24	B+ Overvoltage Cutback <i>Reduced brake torque.</i> <i>Note: This fault is declared only when the controller is running in regen.</i>	<ol style="list-style-type: none"> 1. Normal operation. Fault shows that regen braking currents elevated the battery voltage during regen braking. Controller is performance limited at this voltage. 2. Battery parameters are misadjusted. 3. Battery resistance too high for given regen current. 4. Battery disconnected while regen braking. 5. See Monitor menu >> Battery: Capacitor Voltage. 	<p><i>Set:</i> Capacitor bank voltage exceeded the Overvoltage limit (see page 58) with the FET bridge enabled.</p> <p><i>Clear:</i> Bring capacitor voltage below the Overvoltage limit.</p>
25	+5V Supply Failure <i>None, unless a fault action is programmed in VCL.</i>	<ol style="list-style-type: none"> 1. External load impedance on the +5V supply (pin 26) is too low. 2. See Monitor menu >> outputs: 5 Volts and Ext Supply Current. 	<p><i>Set:</i> +5V supply (pin 26) outside the +5V±10% range.</p> <p><i>Clear:</i> Bring voltage within range.</p>
26	Digital Out 6 Open/Short <i>Digital Output 6 driver will not turn on.</i>	<ol style="list-style-type: none"> 1. External load impedance on Digital Output 6 driver (pin 19) is too low. 	<p><i>Set:</i> Digital Output 6 (pin 19) current exceeded 1 Amp.</p> <p><i>Clear:</i> Remedy the overcurrent cause and use the VCL function <i>Set_DigOut()</i> to turn the driver on again.</p>

CODE	PROGRAMMER LCD DISPLAY EFFECT OF FAULT	POSSIBLE CAUSE	SET/CLEAR CONDITIONS
27	Digital Out 7 Open/Short <i>Digital Output 7 driver will not turn on.</i>	1. External load impedance on Digital Output 7 driver (pin 20) is too low.	<i>Set:</i> Digital Output 7 (pin 20) current exceeded 1 Amp. <i>Clear:</i> Remedy the overcurrent cause and use the VCL function <i>Set_DigOut()</i> to turn the driver on again.
28	Motor Temp Hot Cutback <i>Reduced drive torque.</i>	1. Motor temperature is at or above the programmed Temperature Hot setting, and the current is being cut back. 2. Motor Temperature Control Menu parameters are mis-tuned. 3. See Monitor menu » Motor: Temperature and » Inputs: Analog2. 4. If the application doesn't use a motor thermistor, Temp Compensation and Temp Cutback should be programmed Off.	<i>Set:</i> Motor temperature is at or above the Temperature Hot parameter setting. <i>Clear:</i> Bring the motor temperature within range.
29	Motor Temp Sensor Fault <i>Max:Speed reduced (LOS, Limited Operating Strategy), and motor temperature cutback disabled.</i>	1. Motor thermistor is not connected properly. 2. If the application doesn't use a motor thermistor, Motor Temp Sensor Enable should be programmed Off. 3. See Monitor menu » Motor: Temperature and » Inputs: Analog2.	<i>Set:</i> Motor thermistor input (pin 8) is at the voltage rail (0 or 10V). <i>Clear:</i> Bring the motor thermistor input voltage within range.
31	Coil1 Driver Open/Short <i>ShutdownDriver1.</i>	1. Open or short on driver load. 2. Dirty connector pins. 3. Bad crimps or faulty wiring.	<i>Set:</i> Driver 1 (pin 6) is either open or shorted. This fault can be set only when Main Enable = Off. <i>Clear:</i> Correct open or short, and cycle driver.
31	Main Open/Short <i>ShutdownMotor; ShutdownMainContactor; ShutdownEMBrake; ShutdownThrottle; FullBrake.</i>	1. Open or short on driver load. 2. Dirty connector pins. 3. Bad crimps or faulty wiring.	<i>Set:</i> Main contactor driver (pin 6) is either open or shorted. This fault can be set only when Main Enable = On. <i>Clear:</i> Correct open or short, and cycle driver
32	Coil2 Driver Open/Short <i>ShutdownDriver2.</i>	1. Open or short on driver load. 2. Dirty connector pins. 3. Bad crimps or faulty wiring.	<i>Set:</i> Driver 2 (pin 5) is either open or shorted. This fault can be set only when EM Brake Type = 0. <i>Clear:</i> Correct open or short, and cycle driver.
32	EMBrake Open/Short <i>ShutdownEMBrake; ShutdownThrottle; FullBrake.</i>	1. Open or short on driver load. 2. Dirty connector pins. 3. Bad crimps or faulty wiring.	<i>Set:</i> Electromagnetic brake driver (pin 5) is either open or shorted. This fault can be set only when EM Brake Type >0. <i>Clear:</i> Correct open or short, and cycle driver.
33	Coil3 Driver Open/Short <i>ShutdownDriver3.</i>	1. Open or short on driver load. 2. Dirty connector pins. 3. Bad crimps or faulty wiring.	<i>Set:</i> Driver 3 (pin 4) is either open or shorted. <i>Clear:</i> Correct open or short, and cycle driver.
34	Coil4 Driver Open/Short <i>ShutdownDriver4.</i>	1. Open or short on driver load. 2. Dirty connector pins. 3. Bad crimps or faulty wiring.	<i>Set:</i> Driver 4 (pin 3) is either open or shorted. <i>Clear:</i> Correct open or short, and cycle driver.

CODE	PROGRAMMER LCD DISPLAY EFFECT OF FAULT	POSSIBLE CAUSE	SET/CLEAR CONDITION
35	PD Open/Short <i>ShutdownPD.</i>	<ol style="list-style-type: none"> 1. Open or short on driver load. 2. Dirty connector pins. 3. Bad crimps or faulty wiring. 	<p><i>Set:</i> Proportional driver (pin 2) is either open or shorted.</p> <p><i>Clear:</i> Correct open or short, and cycle driver.</p>
36	Encoder Fault <i>ShutdownEMBrake;</i> <i>Throttle_Command</i> <i>is not processed</i>	<ol style="list-style-type: none"> 1. Motor encoder failure. 2. Bad crimps or faulty wiring. 3. See Monitor menu » Motor: Motor RPM. 	<p><i>Set:</i> Motor encoder phase failure detected.</p> <p><i>Clear:</i> Cycle KSI.</p>
37	Motor Open <i>ShutdownMotor;</i> <i>ShutdownMainContactor;</i> <i>ShutdownEMBrake;</i> <i>ShutdownThrottle;</i> <i>FullBrake.</i>	<ol style="list-style-type: none"> 1. Motor phase is open. 2. Bad crimps or faulty wiring. 	<p><i>Set:</i> Motor phase U, V, or W detected open.</p> <p><i>Clear:</i> Cycle KSI.</p>
38	Main Contactor Welded <i>ShutdownMotor;</i> <i>ShutdownMainContactor;</i> <i>ShutdownEMBrake;</i> <i>ShutdownThrottle;</i> <i>FullBrake.</i>	<ol style="list-style-type: none"> 1. Main contactor tips are welded closed. 2. Motor phase U or V is disconnected or open. 3. An alternate voltage path (such as an external precharge resistor) is providing a current to the capacitor bank (B+ connection terminal). 	<p><i>Set:</i> Just prior to the main contactor closing, the capacitor bank voltage (B+ connection terminal) was loaded for a short time and the voltage did not discharge.</p> <p><i>Clear:</i> Cycle KSI</p>
39	Main Contactor Did Not Close <i>ShutdownMotor;</i> <i>ShutdownMainContactor;</i> <i>ShutdownEMBrake;</i> <i>ShutdownThrottle;</i> <i>FullBrake.</i>	<ol style="list-style-type: none"> 1. Main contactor did not close. 2. Main contactor tips are oxidized, burned, or not making good contact. 3. External load on capacitor bank (B+ connection terminal) that prevents capacitor bank from charging. 4. Blown B+ fuse. 	<p><i>Set:</i> With the main contactor commanded closed, the capacitor bank voltage (B+ connection terminal) did not charge to B+.</p> <p><i>Clear:</i> Cycle KSI.</p>
41	Throttle Wiper High <i>ShutdownThrottle.</i>	<ol style="list-style-type: none"> 1. See Monitor menu » Inputs: Throttle Pot. 2. Throttle pot wiper voltage too high. 	<p><i>Set:</i> Throttle pot wiper (pin 16) voltage is higher than the high fault threshold (can be changed with the VCL function <i>Setup_Pot_Faults()</i>).</p> <p><i>Clear:</i> Bring throttle pot wiper voltage below the fault threshold.</p>
42	Throttle Wiper Low <i>ShutdownThrottle.</i>	<ol style="list-style-type: none"> 1. See Monitor menu » Inputs: Throttle Pot. 2. Throttle pot wiper voltage too low. 	<p><i>Set:</i> Throttle pot wiper (pin 16) voltage is lower than the low fault threshold (can be changed with the VCL function <i>Setup_Pot_Faults()</i>).</p> <p><i>Clear:</i> Bring throttle pot wiper voltage above the fault threshold.</p>
43	Pot2 Wiper High <i>FullBrake.</i>	<ol style="list-style-type: none"> 1. See Monitor menu » Inputs: Pot2 Raw. 2. Pot2 wiper voltage too high. 	<p><i>Set:</i> Pot2 wiper (pin 17) voltage is higher than the high fault threshold (can be changed with the VCL function <i>Setup_Pot_Faults()</i>).</p> <p><i>Clear:</i> Bring Pot2 wiper voltage below the fault threshold.</p>

CODE	PROGRAMMER LCD DISPLAY <i>EFFECT OF FAULT</i>	POSSIBLE CAUSE	SET/CLEAR CONDITIONS
44	Pot2 Wiper Low <i>FullBrake.</i>	<ol style="list-style-type: none"> 1. See Monitor menu >> Inputs: Pot2 Raw. 2. Pot2 wiper voltage too low. 	<p><i>Set:</i> Pot2 wiper (pin 17) voltage is lower than the low fault threshold (can be changed with the VCL function <i>Setup_Pot_Faults()</i>).</p> <p><i>Clear:</i> Bring Pot2 wiper voltage above the fault threshold.</p>
45	Pot Low OverCurrent <i>ShutdownThrottle;</i> <i>FullBrake.</i>	<ol style="list-style-type: none"> 1. See Monitor menu >> Outputs: Pot Low. 2. Combined pot resistance connected to pot low is too low. 	<p><i>Set:</i> Pot low (pin 18) current exceeds 10mA.</p> <p><i>Clear:</i> Clear pot low overcurrent condition and cycle KSI.</p>
46	EEPROM Failure <i>ShutdownMotor;</i> <i>ShutdownMainContactor;</i> <i>ShutdownEMBrake;</i> <i>ShutdownThrottle;</i> <i>ShutdownInterlock;</i> <i>ShutdownDriver1;</i> <i>ShutdownDriver2;</i> <i>ShutdownDriver3;</i> <i>ShutdownDriver4;</i> <i>ShutdownPD;</i> <i>FullBrake.</i>	<ol style="list-style-type: none"> 1. Failure to write to EEPROM memory. This can be caused by EEPROM memory writes initiated by VCL, by the CANbus, by adjusting parameters with the programmer, or by loading new software into the controller. 	<p><i>Set:</i> Controller operating system tried to write to EEPROM memory and failed.</p> <p><i>Clear:</i> Download the correct software (OS) and matching parameter default settings into the controller and cycle KSI.</p>
47	HPD/Sequencing Fault <i>ShutdownThrottle.</i>	<ol style="list-style-type: none"> 1. KSI, interlock, direction, and throttle inputs applied in incorrect sequence. 2. Faulty wiring, crimps, or switches at KSI, interlock, direction, or throttle inputs. 3. See Monitor menu >> Inputs. 	<p><i>Set:</i> HPD (High Pedal Disable) or sequencing fault caused by incorrect sequence of KSI, interlock, direction, and throttle inputs.</p> <p><i>Clear:</i> Reapply inputs in correct sequence.</p>
47	Emer Rev HPD <i>ShutdownThrottle;</i> <i>ShutdownEMBrake.</i>	<ol style="list-style-type: none"> 1. Emergency Reverse operation has concluded, but the throttle, forward and reverse inputs, and interlock have not been returned to neutral. 	<p><i>Set:</i> At the conclusion of Emergency Reverse, the fault was set because various inputs were not returned to neutral.</p> <p><i>Clear:</i> If EMR_Interlock = On, clear the interlock, throttle, and direction inputs. If EMR_Interlock = Off, clear the throttle and direction inputs.</p>
49	Parameter Change Fault <i>ShutdownMotor;</i> <i>ShutdownMainContactor;</i> <i>ShutdownEMBrake;</i> <i>ShutdownThrottle;</i> <i>FullBrake.</i>	<ol style="list-style-type: none"> 1. This is a safety fault caused by a change in certain parameter settings so that the vehicle will not operate until KSI is cycled. For example, if a user changes the Throttle Type this fault will appear and require cycling KSI before the vehicle can operate. 	<p><i>Set:</i> Adjustment of a parameter setting that requires cycling of KSI.</p> <p><i>Clear:</i> Cycle KSI.</p>
51–67	OEM Faults <i>(See OEM documentation.)</i>	<ol style="list-style-type: none"> 1. These faults can be defined by the OEM and are implemented in the application-specific VCL code. See OEM documentation. 	<p><i>Set:</i> See OEM documentation.</p> <p><i>Clear:</i> See OEM documentation.</p>

CODE	PROGRAMMER LCD DISPLAY EFFECT OF FAULT	POSSIBLE CAUSE	SET/CLEAR CONDITIONS
68	VCL Run Time Error <i>ShutdownMotor;</i> <i>ShutdownMainContactor;</i> <i>ShutdownEMBrake;</i> <i>ShutdownThrottle;</i> <i>ShutdownInterlock;</i> <i>ShutdownDriver1;</i> <i>ShutdownDriver2;</i> <i>ShutdownDriver3;</i> <i>ShutdownDriver4;</i> <i>ShutdownPD;</i> <i>FullBrake.</i>	<ol style="list-style-type: none"> 1. VCL code encountered a runtime VCL error. 2. See Monitor menu >> Controller: VCL Error Module and VCL Error. This error can then be compared to the runtime VCL module ID and error code definitions found in the specific OS system information file. 	<p><i>Set:</i> Runtime VCL code error condition. <i>Clear:</i> Edit VCL application software to fix this error condition; flash the new compiled software and matching parameter defaults; cycle KSI.</p>
69	External Supply Out of Range <i>None, unless a fault action is programmed in VCL.</i>	<ol style="list-style-type: none"> 1. External load on the 5V and 12V supplies draws either too much or too little current. 2. Fault Checking Menu parameters Ext Supply Max and Ext Supply Min are mis-tuned. 3. See Monitor menu >> Outputs: Ext Supply Current. 	<p><i>Set:</i> The external supply current (combined current used by the 5V supply [pin 26] and 12V supply [pin 25]) is either greater than the upper current threshold or lower than the lower current threshold. The two thresholds are defined by the External Supply Max and External Supply Min parameter settings (page 53). <i>Clear:</i> Bring the external supply current within range.</p>
71	OS General <i>ShutdownMotor;</i> <i>ShutdownMainContactor;</i> <i>ShutdownEMBrake;</i> <i>ShutdownThrottle;</i> <i>ShutdownInterlock;</i> <i>ShutdownDriver1;</i> <i>ShutdownDriver2;</i> <i>ShutdownDriver3;</i> <i>ShutdownDriver4;</i> <i>ShutdownPD;</i> <i>FullBrake.</i>	<ol style="list-style-type: none"> 1. Internal controller fault. 	<p><i>Set:</i> Internal controller fault detected. <i>Clear:</i> Cycle KSI.</p>
72	PDO Timeout <i>ShutdownThrottle;</i> <i>CAN NMT State set to Pre-operational.</i>	<ol style="list-style-type: none"> 1. Time between CAN PDO messages received exceeded the PDO Timeout Period. 	<p><i>Set:</i> Time between CAN PDO messages received exceeded the PDO Timeout Period. <i>Clear:</i> Cycle KSI or receive CAN NMT message.</p>
73	Stall Detected <i>ShutdownEMBrake;</i> <i>Throttle_Command is not processed;</i> <i>Control Mode changed to LOS (Limited Operating Strategy).</i>	<ol style="list-style-type: none"> 1. Stalled motor. 2. Motor encoder failure. 3. Bad crimps or faulty wiring. 4. Problems with power supply for the motor encoder. 5. See Monitor menu >> Motor: Motor RPM. 	<p><i>Set:</i> No motor encoder movement detected. <i>Clear:</i> Either cycle KSI, or detect valid motor encoder signals while operating in LOS mode and return Throttle Command = 0 and Motor RPM = 0.</p>

CODE	PROGRAMMER LCD DISPLAY <i>EFFECT OF FAULT</i>	POSSIBLE CAUSE	SET/CLEAR CONDITIONS
74	Fault On Other Traction Controller	Dual Drive fault: see Dual Drive manual.	
75	Dual Severe Fault	Dual Drive fault: see Dual Drive manual.	
77	Supervisor Fault <i>ShutdownMotor;</i> <i>ShutdownMainContactor;</i> <i>ShutdownEMBrake;</i> <i>ShutdownThrottle;</i> <i>ShutdownInterlock;</i> <i>ShutdownDriver1;</i> <i>ShutdownDriver2;</i> <i>ShutdownDriver3;</i> <i>ShutdownDriver4;</i> <i>ShutdownPD;</i> <i>FullBrake.</i>	<ol style="list-style-type: none"> 1. The Supervisor has detected a mismatch in redundant readings. 2. Internal damage to Supervisor microprocessor. 3. Switch inputs allowed to be within upper and lower thresholds for over 100 milliseconds. 	<i>Set:</i> Mismatched redundant readings; damaged Supervisor; illegal switch inputs. <i>Clear:</i> Check for noise or voltage drift in all switch inputs; check connections; cycle KSI.
78	Supervisor Incompatible <i>ShutdownMotor;</i> <i>ShutdownMainContactor;</i> <i>ShutdownEMBrake;</i> <i>ShutdownThrottle;</i> <i>ShutdownInterlock;</i> <i>ShutdownDriver1;</i> <i>ShutdownDriver2;</i> <i>ShutdownDriver3;</i> <i>ShutdownDriver4;</i> <i>ShutdownPD;</i> <i>FullBrake.</i>	<ol style="list-style-type: none"> 1. The main OS is not compatible with the Supervisor OS. 	<i>Set:</i> Incompatible software. <i>Clear:</i> Load properly matched OS code or update the Supervisor code; cycle KSI.
82	Bad Calibrations <i>ShutdownMotor;</i> <i>ShutdownMainContactor;</i> <i>ShutdownEMBrake;</i> <i>ShutdownThrottle;</i> <i>FullBrake.</i>	<ol style="list-style-type: none"> 1. Internal controller fault. 	<i>Set:</i> Internal controller fault detection. <i>Clear:</i> Cycle KSI.
83	Driver Supply <i>ShutdownMotor;</i> <i>ShutdownMainContactor;</i> <i>ShutdownEMBrake;</i> <i>ShutdownThrottle;</i> <i>FullBrake.</i>	<ol style="list-style-type: none"> 1. Internal controller fault in the voltage supply for the driver circuits. 	<i>Set:</i> Internal controller fault detection. <i>Clear:</i> Cycle KSI.

CODE	PROGRAMMER LCD DISPLAY EFFECT OF FAULT	POSSIBLE CAUSE	SET/CLEAR CONDITIONS
87	Motor Characterization Fault <i>ShutdownMotor;</i> <i>ShutdownMainContactor;</i> <i>ShutdownEMBrake;</i> <i>ShutdownThrottle;</i> <i>FullBrake.</i>	1. Motor characterization failed during characterization process. See Monitor menu » Controller: Motor Characterization Error for cause: 0=none 1=encoder signal seen, but step size not determined; set Encoder Step Size manually 2=motor temp sensor fault 3=motor temp hot cutback fault 4= controller overtemp cutback fault 5=controller undertemp cutback fault 6=undervoltage cutback fault 7=severe overvoltage fault 8=encoder signal not seen, or one or both channels missing 9=motor parameters out of characterization range.	<i>Set:</i> Motor characterization failed during the motor characterization process. <i>Clear:</i> Correct fault; cycle KSI.
88	Encoder Pulse Count Fault <i>ShutdownMotor;</i> <i>ShutdownMainContactor;</i> <i>ShutdownEMBrake;</i> <i>ShutdownThrottle;</i> <i>ShutdownInterlock;</i> <i>ShutdownDriver1;</i> <i>ShutdownDriver2;</i> <i>ShutdownDriver3;</i> <i>ShutdownDriver4;</i> <i>ShutdownPD;</i> <i>FullBrake.</i>	1. Encoder Steps parameter does not match the actual motor encoder.	<i>Set:</i> Motor lost IFO control and accelerated without throttle command. <i>Clear:</i> Ensure the Encoder Steps parameter matches the actual encoder; cycle KSI.
89	Motor Type Fault <i>ShutdownMotor;</i> <i>ShutdownMainContactor;</i> <i>ShutdownEMBrake;</i> <i>ShutdownThrottle;</i> <i>FullBrake.</i>	1. The Motor_Type parameter value is out of range.	<i>Set:</i> Motor_Type parameter is set to an illegal value. <i>Clear:</i> Set Motor_Type to correct value and cycle KSI.
91	VCL/OS Mismatch <i>ShutdownMotor;</i> <i>ShutdownMainContactor;</i> <i>ShutdownEMBrake;</i> <i>ShutdownThrottle;</i> <i>ShutdownInterlock;</i> <i>ShutdownDriver1;</i> <i>ShutdownDriver2;</i> <i>ShutdownDriver3;</i> <i>ShutdownDriver4;</i> <i>ShutdownPD;</i> <i>FullBrake.</i>	1. The VCL software in the controller does not match the OS software in the controller.	<i>Set:</i> VCL and OS software do not match; when KSI cycles, a check is made to verify that they match and a fault is issued when they do not. <i>Clear:</i> Download the correct VCL and OS software into the controller.

CODE	PROGRAMMER LCD DISPLAY EFFECT OF FAULT	POSSIBLE CAUSE	SET/CLEAR CONDITIONS
92	EM Brake Failed to Set <i>ShutdownEMBrake;</i> <i>ShutdownThrottle.</i> <i>Position Hold is engaged</i> <i>when Interlock=On.</i>	<ol style="list-style-type: none"> 1. Vehicle movement sensed after the EM Brake has been commanded to set. 2. EM Brake will not hold the motor from rotating. 	<p><i>Set:</i> After the EM Brake was commanded to set and time has elapsed to allow the brake to fully engage, vehicle movement has been sensed.</p> <p><i>Clear:</i> Activate the throttle.</p>
93	Encoder LOS (Limited Operating Strategy) <i>Enter LOS control mode.</i>	<ol style="list-style-type: none"> 1. Limited Operating Strategy (LOS) control mode has been activated, as a result of either an Encoder Fault (Code 36) or a Stall Detect Fault (Code 73). 2. Motor encoder failure. 3. Bad crimps or faulty wiring. 4. Vehicle is stalled. 	<p><i>Set:</i> Encoder Fault (Code 36) or Stall Detect Fault (Code 73) was activated, and Brake or Interlock has been applied to activate LOS control mode, allowing limited motor control.</p> <p><i>Clear:</i> Cycle KSI or, if LOS mode was activated by the Stall Fault, clear by ensuring encoder senses proper operation, Motor RPM = 0, and Throttle Command = 0.</p>
94	EMR Rev Timeout <i>ShutdownEMBrake;</i> <i>ShutdownThrottle.</i>	<ol style="list-style-type: none"> 1. Emergency Reverse was activated and concluded because the EMR Timeout timer has expired. 2. The emergency reverse input is stuck On. 	<p><i>Set:</i> Emergency Reverse was activated and ran until the EMR Timeout timer expired.</p> <p><i>Clear:</i> Turn the emergency reverse input Off.</p>
98	Illegal Model Number <i>ShutdownMotor;</i> <i>ShutdownMainContactor;</i> <i>ShutdownEMBrake;</i> <i>ShutdownThrottle;</i> <i>FullBrake;</i>	<ol style="list-style-type: none"> 1. Model_Number variable contains illegal value. 2. Software and hardware do not match. 3. Controller defective. 	<p><i>Set:</i> Illegal Model_Number variable; when KSI cycles, a check is made to confirm a legal Model_Number, and a fault is issued if one is not found.</p> <p><i>Clear:</i> Download appropriate software for your controller model.</p>
99	Dualmotor Parameter Mismatch	Dual Drive fault: see Dual Drive manual.	

Manufacturer:

Actil Warehouse Trucks AB
Flemma Muggebo 2
SE 585 78 Vreta Kloster
www.actil.se

Sales and customer service:

STILL GmbH
Berzeliusstraße 10
22113 Hamburg
Telephone: +46 (0) 40 7339-0
Telefax: +49 (0) 40 7339-1622

STILL GmbH

500237-22-22104 → 500237-22-22188