

STILL iGo Technical Data

Scalable Automation Solutions

EXV iGo

FM-X iGo

MX-X iGo



STILL iGo Automation Solutions We drive automated vehicles

With **STILL iGo**, we offer various truck-based extension levels for the automation of your intralogistics which can be individually adapted to your requirements. Hardly any other solution offers as much potential for process optimisation, data exchange and networking as automated systems do. Robots, autonomous trucks and automated guided vehicles (AGV) play a key role in this area.

Given all this, it is no wonder that there has been so much development in the last few years. Today, we are seeing significant investment and research in a multitude of R&D areas – and not just by the major AGV manufacturers. Hundreds of start-ups, technology companies and software firms are also keen to break into the market in this field. With our wealth of experience and expertise in automation, we will be at your side right from the start to make sure that you find the perfect automation solution for you from among the numerous options on the market.



EXV iGo
Automated high lift pallet truck



FM-X iGo
Automated reach truck



MX-X iGo
Automated very narrow aisle truck



Typical automation scenarios

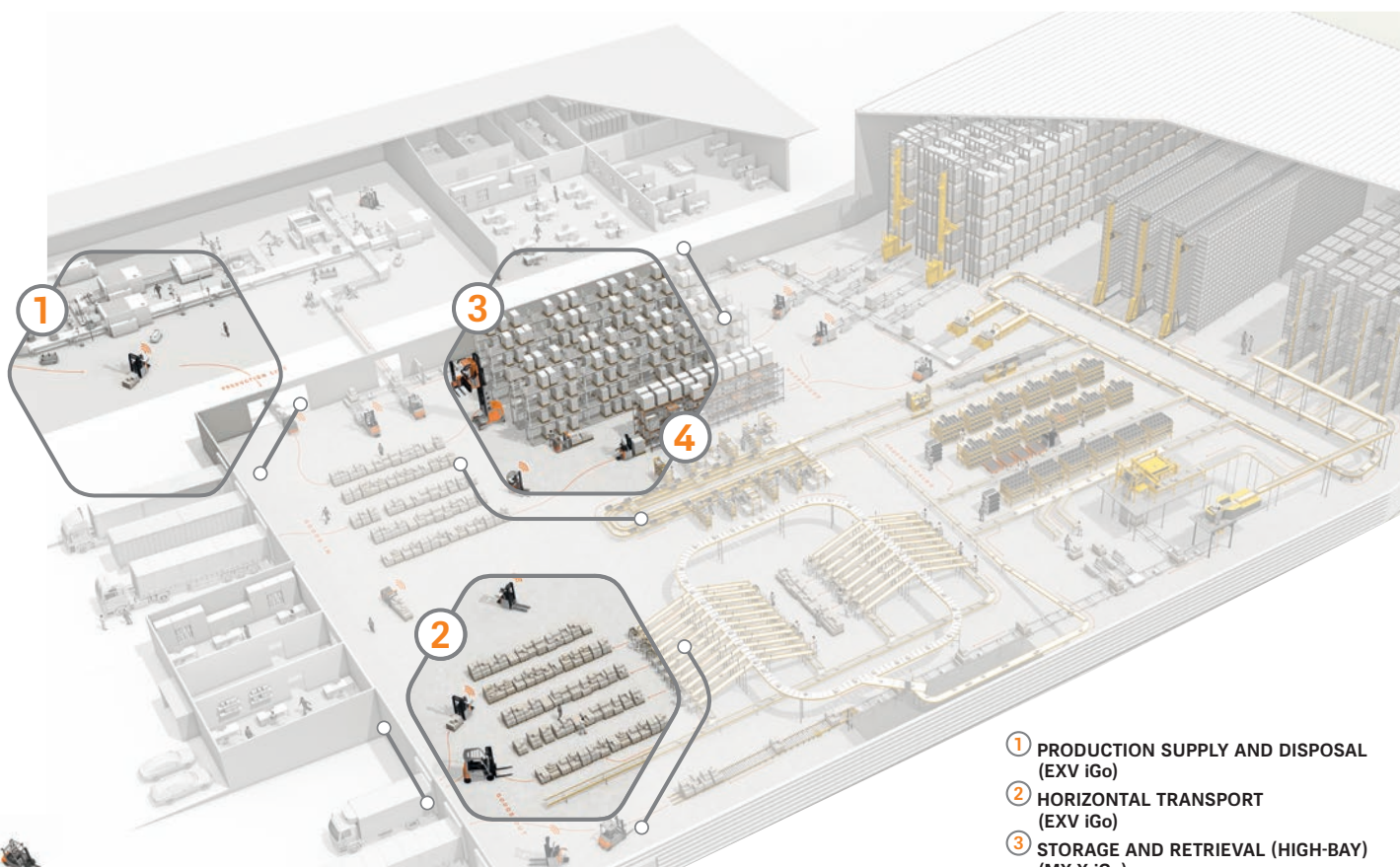

- 1 PRODUCTION SUPPLY AND DISPOSAL (EXV iGo)
- 2 HORIZONTAL TRANSPORT (EXV iGo)
- 3 STORAGE AND RETRIEVAL (HIGH-BAY) (MX-X iGo)
- 4 STORAGE AND RETRIEVAL (WIDE-AISLE WAREHOUSE OR BLOCK STORAGE) (EXV iGo and FM-X iGo)

More complex. Faster. Better value. Are you also confronted with challenges like these every day when competing for satisfied customers?

- **Delivery delays** due to rising order intake
- **Warehouse capacities** are reaching their limits
- **Warehouse employees** are exposed to high physical stress
- **Inefficient processes** caused by errors, empty runs and transport damage
- **Skills shortage**

If so, you should consider automating your intralogistics processes – it is a highly productive and cost-effective way to solve problems like these. STILL offers a wide range of different solutions and truck-based configuration levels to help you automate your processes.

They can be adapted to the complexity of your requirements, meaning that they are guaranteed to pay off every time.



Automation with STILL iGo

Not every technological innovation is always financially feasible for every task. We will be your partner and ensure that you do not get lost amid the vast array of digital offers available as part of Industry 4.0.

No matter what stage of your automation project you are at, we will identify just the right mix of technical solutions for your intralogistics and will always keep a close eye on your return on investment.

- **Future-proof.** Standardised and scalable solutions for every automation requirement

- **Cost-effective.** The right automation solutions in terms of ROI
- **Flexible.** Various stages of automation: the level of automation is based on your processes
- **Safe.** State-of-the-art navigation technologies and pedestrian protection
- **Complete.** Mobile and stationary solutions for completely automated delivery chains
- **Predictable.** Short response times in the design and quotation preparation stages, as well as in the implementation of projects

Warehouse applications

With STILL iGo, you can increase the efficiency of your processes and pave the way for smart processes. Whether in a wide-aisle or narrow-aisle warehouse, in block storage, in production supply or goods receipt and dispatch – iGo systems enables you to automate the entire range of your warehouse processes. Very narrow aisle trucks, reach trucks and high lift

pallet trucks can be networked in an intelligent system and, depending on requirements, it is even possible to do this in conjunction with hybrid or manually operated trucks. Different transfer stations enable different trucks to work together seamlessly, and make it possible to transport a range of load carriers. This ensures maximum flexibility and productivity.

Individual automation solutions tailored to your precise requirements. STILL iGo enables automated interaction between one or more different trucks so that transport tasks in the warehouse can be performed without a driver. Our many years of experience have taught us that different warehouse situations require different solutions. With STILL iGo, we offer you various solutions for the automation of your processes that can be flexibly and scalably adapted to your requirements - and therefore always pay off.

Analysis, planning, implementation. Put your trust in automation that meets your needs and delivers maximum efficiency by selecting the best technologies for your requirements. This means that you can always stay flexible because all automated STILL series-produced trucks can also be operated manually in the worst-case scenario. Once your tailor-made automation solution has been implemented, a professional, custom service model guarantees that your system is available at all times.



Charging and chargers



Smart automation also means smart charging. After all, tailor-made energy and charging concepts that are integrated into the overall process ensure that your fleet is always available. Therefore, in accordance with the level of automation in your warehouse, you also need to consider the automation of your charging concept, which may include manual, hybrid or fully automated charging processes. Having the right energy system also plays an important role here. Whether lead-acid or lithium-ion batteries are the best choice for you depends

on factors such as truck utilisation, charging slots and charging infrastructure. Is there scope for changing batteries or charging them between shifts? Or would flexible opportunity charging during short breaks fit better into your workflow? Our logistics experts will be happy to help you answer these questions and to put together the perfect solution for you from our comprehensive and flexible portfolio to meet your needs and objectives.

An automated warehouse offers many advantages. In addition to increasing efficiency and safety, the value-creating use of resources also plays an important role: when intelligent machines take over physically demanding and repetitive work, this frees up employees to focus on more creative and responsible tasks.

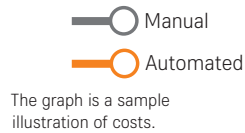

ONE-SHIFT OPERATION COSTS

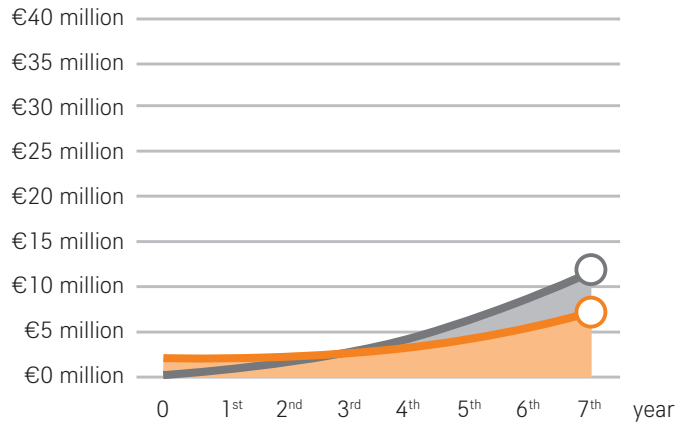

AND YOU ALSO BENEFIT FROM A COST-EFFICIENCY PERSPECTIVE:

- Increased handling capacity and maximum productivity – 24/7 if required
- Significantly reduced accident rate and optimum safety for people and machines
- Less damage to goods, materials and trucks
- Minimal error rate thanks to intelligent systems
- Greater independence from the labour market while becoming more attractive as a place to work

TWO-SHIFT OPERATION COSTS

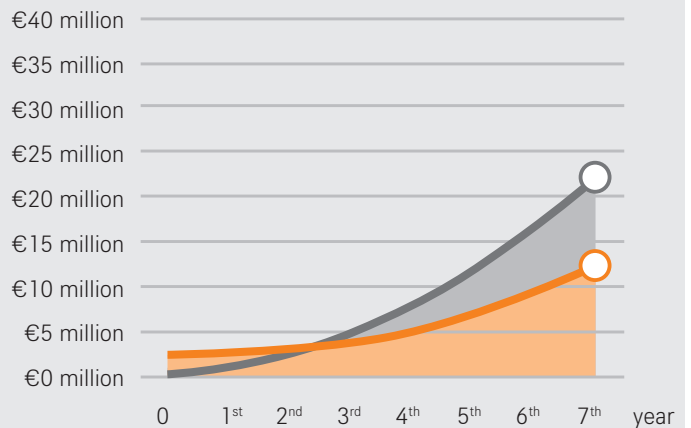

AUTOMATION - AN INVESTMENT THAT PAYS OFF

Even in the very first year and in one-shift operation, you can achieve significant savings on annual costs, for example when comparing a manual warehouse with three trucks to an automated warehouse with four AGVs. Naturally, lower personnel costs play a big role in this, but potential additional costs and downtime costs are also much lower thanks to the high level of process reliability. Particularly when viewed over the course of several years, the cumulative costs clearly demonstrate the savings potential of automated processes. Not to mention the future viability.

THREE-SHIFT OPERATION COSTS

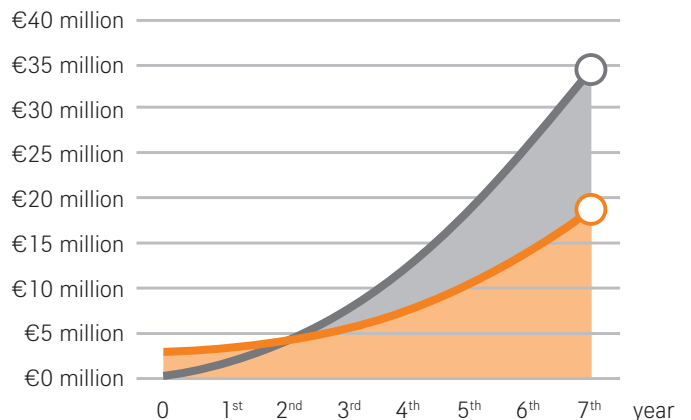

EXV iGo Automated High Lift Pallet Truck

We drive automated vehicles

This specification sheet, which conforms to VDI guideline 2198, provides the technical values for the standard equipment only. Different tyres, other masts, additional equipment, etc. may produce different values.



Features	1.1	Manufacturer			STILL	
	1.2	Manufacturer's type designation			EXV iGo	
	1.3	Drive			Electric	
	1.4	Operation			Manual/automated	
	1.5	Rated capacity/rated load	Q	kg	1600	
	1.6	Load capacity at load centre distance	c	mm	625	
	1.8	Load centre distance	x	mm	701	
	1.9	Wheel base	y	mm	1386	
	Weights	2.1	Service weight (incl. battery)		kg	1550
2.2		Axle load, laden	drive end/load end	kg	1239/1912	
2.3		Axle load, unladen	drive end/load end	kg	1146/404	
Tyres/chassis	3.1	Tyres			Rubber + polyurethane/ polyurethane	
	3.2	Tyre size	drive end	mm	Ø 230 x 90	
	3.3	Tyre size	load end	mm	Ø 85 x 85	
	3.4	Additional wheels		mm	Ø 150 x 50	
	3.5	Number of wheels (x = driven)	drive end/load end		1 x + 1/2	
	3.6	Track width	drive end/load end	b ₁₀ /b ₁₁	mm	534/380
Dimensions	4.2	Height, mast lowered		h ₁	mm	1915
	4.3	Free lift		h ₂	mm	150
	4.4	Lift		h ₃	mm	2844
	4.5	Height, mast extended		h ₄	mm	1915
	4.6	Initial lift		h ₅	mm	-
	4.7	Height of overhead guard		h ₆	mm	2443
	4.9	Height of drawbar in driving position	min./max.	h ₁₄	mm	1163/698
	4.15	Fork height, lowered		h ₁₃	mm	86
	4.19	Overall length		l ₁	mm	2208 ¹
	4.20	Length to face of forks		l ₂	mm	966 ¹
	4.21	Overall width		b ₁	mm	1000
	4.22	Fork dimensions DIN ISO 2331		s/e/l	mm	71/182/1250
	4.24	Fork carriage width		b ₃	mm	780
	4.25	Distance between fork arms		b ₅	mm	560
	4.26	Distance between wheel arms		b ₄	mm	255
4.32	Ground clearance, centre of wheel base		m ₂	mm	20	
4.34.1	Aisle width for pallets 1000 x 1200 crossways		A _{st}	mm	3075 ^{1,2}	
4.34.2	Aisle width for pallets 800 x 1200 lengthways		A _{st}	mm	2925 ^{1,2}	
4.35	Turning radius in manual mode		W _a	mm	1744 ¹	
Performance data	5.1	Travel speed	laden/unladen	m/s	2.0/2.0	
	5.2	Lifting speed	laden/unladen	m/s	0.16/0.30	
	5.3	Lowering speed	laden/unladen	m/s	0.40/0.35	
	5.10	Service brake				Electromagnetic
Electric engine	6.1	Drive motor rating S2 = 60 min		kW	2.3	
	6.2	Lift motor rating S3 = 15%		kW	3.2	
	6.3	Battery according to DIN 43531/35/36 A, B, C, no				3PzS
	6.4	Battery voltage/rated capacity K _s		V/Ah kWh		24/375 Li-Ion: 12
	6.5	Battery weight ±5% (depends on make)		kg		333
	6.6	Energy consumption in relation to VDI cycle (15 cycles/1 h)		kWh/h		0.925 ³
Misc.	8.1	Drive control				AC control
	8.4	Sound pressure level at driver's seat			dB(A)	<66

¹ +75 mm with 4PzS battery

² Minimum aisle width A_{st} with reduced speed

³ At a nominal capacity of 1600 kg

Please note: This is a sample configuration. Depending on the use of the truck, the values may differ.

Mast Tables

EXV iGo systems	Telescopic mast					
Height	h ₁	mm	1915	2115	2365	
Mast height with activated free lift (h ₃ = 150 mm)	h ₁ '	mm	1990	2190	2640	
Free lift ¹	h ₂	mm	150	150	150	
Lift	h ₃	mm	2844	3244	3744	
Height, mast extended	h ₄	mm	3364	3764	4264	
Maximum storage height ²	h	mm	2780	3180	3680	

¹ With increased mast height h₁'

² Considering free lift and load detection: h = h₃ + h₁₃ - h₂

EXV iGo Automated High Lift Pallet Truck

Technical Drawings

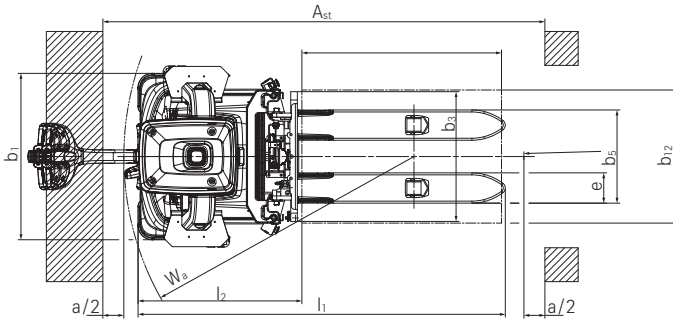

Top view EXV iGo

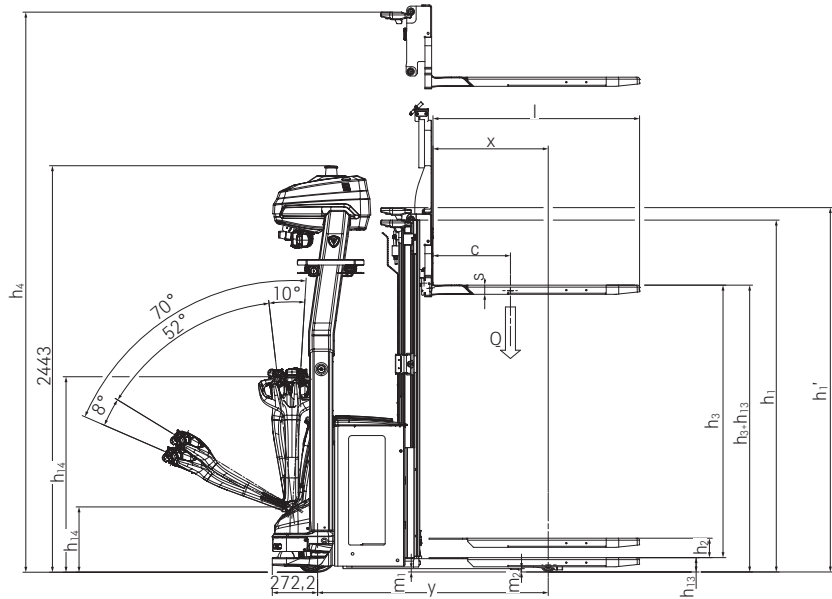

Side view EXV iGo

Basic Load Capacities

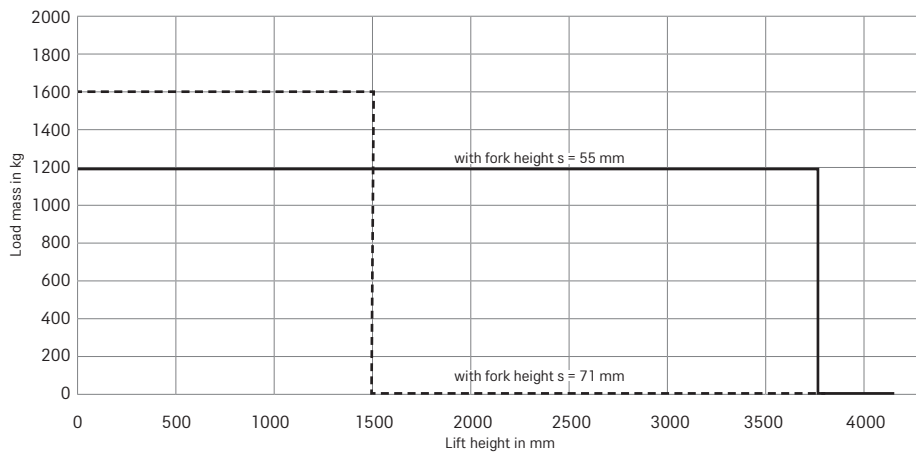

1. This diagram shows the loads and shelf heights for which the automated truck can transport, store and retrieve loads safely, reliably and consistently.

2. The ability to automate storage and retrieval depends not only on the truck, but also on other factors such as the load carriers, the nature of the load and the transfer stations to be operated. Suitability must therefore be confirmed on a project-specific basis.

EXV iGo Automated High Lift Pallet Truck Detailed Photos



Excellent operator safety thanks to reliable 360-degree safety laser on the truck



The entire charging process of the EXV iGo can be fully automated: Charging contacts for both lithium-ion and lead-acid batteries



Dynamic safety fields around the truck ensure maximum safety and collision avoidance: Real-time adjustment of the driving speed depending on corner radius

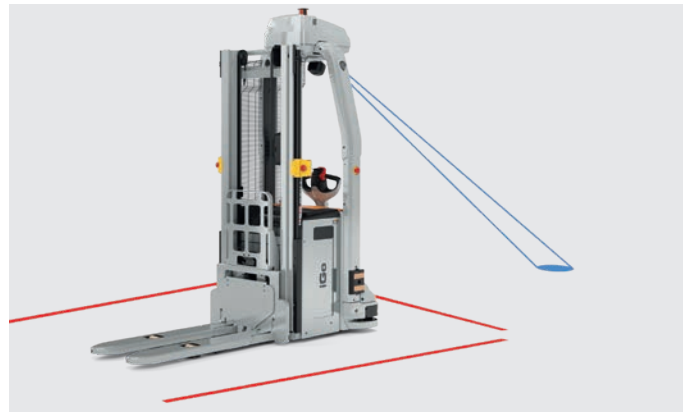

Eye-catching warning lights for high visibility and recognition of the truck



Large touch screen at eye level for intuitive operation and maximum ease of use



Reliable collision avoidance with additional sensors for detecting obstacles in the truck's environment



Experience and know-how: STILL's tried and tested truck technology is the basis of our reliable, safe and efficient goods transport



No aisle too narrow, no warehouse too small: The EXV iGo boasts impressively compact dimensions and high manoeuvrability

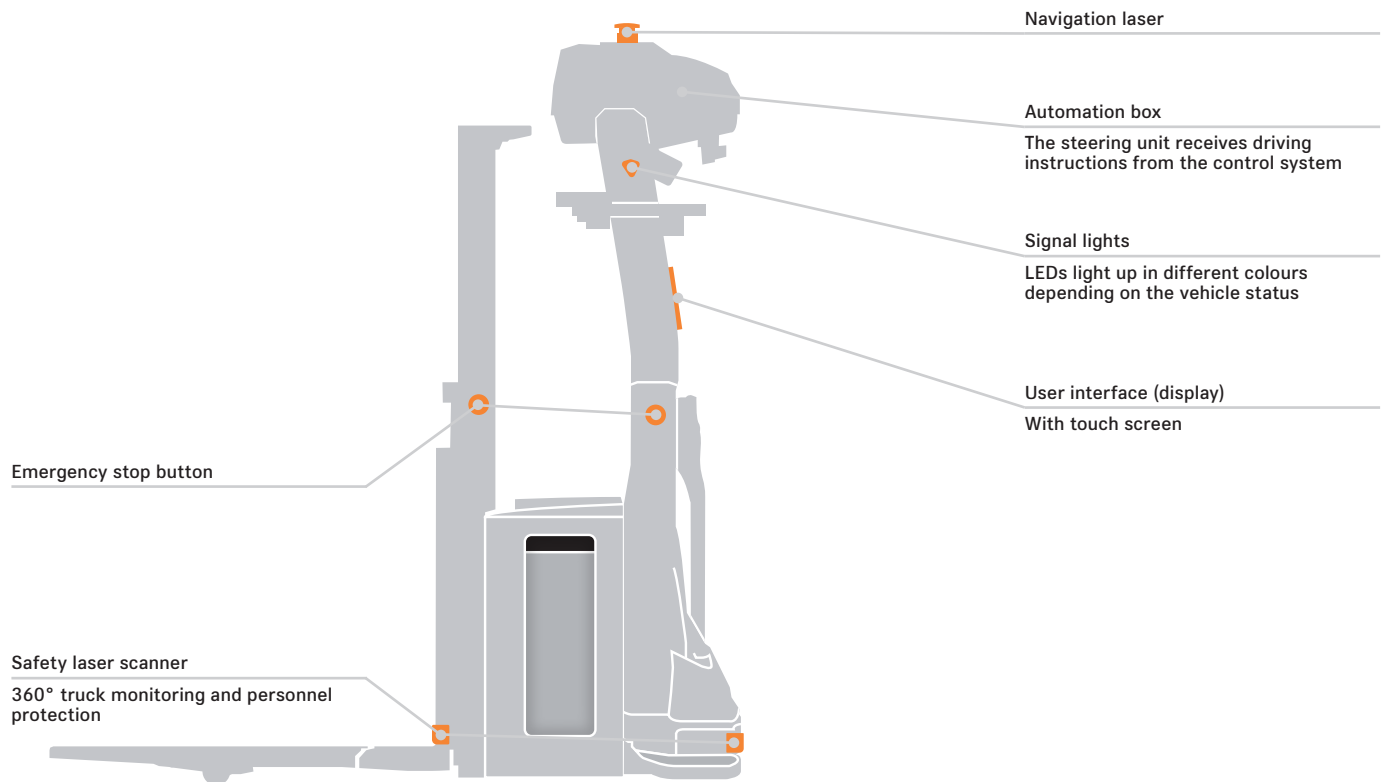

Advantages of automated high lift pallet trucks

Automated high lift pallet trucks are efficient, safe and powerful, and – combined with other driverless transport systems – pave the way for highly efficient, safe and flexible logistics processes. The EXV iGo is the perfect truck for setting new standards, particularly in production logistics and the pre-storage zone. It excels in storage and retrieval in wide-aisle and block storage systems, at high rack warehouse transfer stations, in automatic route provision, and also in horizontal transport – for the latter it can also easily handle longer distances with a maximum speed of 2.0 m/s. The truck's high residual load capacity and a lift height of up to 3.8 metres make it a reliable and powerful partner for storage and retrieval. The EXV iGo can easily be integrated into existing IT structures, or be used as a stand-alone system for simple, repeat

transport tasks. It guarantees optimal process reliability, precision and maximum safety, even in mixed operation. This is ensured by the 360° personnel protection, which protects people, the truck and the load using sensitive scanners and sensors. The following safety features are integrated as standard: a safety laser scanner that detects people and objects in the path of travel; visual and acoustic warning systems (e. g. when changing direction of travel); and an emergency stop button that can be used to bring the forklift truck to an immediate standstill. The EXV can be operated in dual operation if required.

Industrialised AGVs (automated guided vehicles) are powerful components for optimising your warehouse and your logistics.

FM-X iGo Automated Reach Truck
We drive automated vehicles

This specification sheet, which conforms to VDI guideline 2198, provides the technical values for the standard equipment only. Different tyres, other masts, additional equipment, etc. may produce different values.



				STILL	STILL	STILL	STILL	STILL		
Features	1.1	Manufacturer								
	1.2	Manufacturer's type designation		FM-X 12 iGo	FM-X 14 iGo	FM-X 17 iGo	FM-X 20 iGo	FM-X 25 iGo		
	1.3	Drive		Electric	Electric	Electric	Electric	Electric		
	1.4	Operation		Manual/automated	Manual/automated	Manual/automated	Manual/automated	Manual/automated		
	1.5	Rated capacity/rated load	Q	kg	1100	1300	1600	1900	2400	
	1.6	Load centre distance	c	mm	600	600	600	600	600	
	1.8	Load distance, centre of drive axle to fork	x	mm	278	348	410	410	482	
	1.9	Wheel base	y	mm	1275	1381	1453	1525	1669	
	2.1	Service weight (incl. battery)		kg	3340	3570	3570	3920	4210	
Weights	2.3	Axle load, unladen		drive end/load end	kg	2150/1180	2270/1300	2310/1260	2490/1430	2660/1550
	2.4	Axle load, fork raised, laden		drive end/load end	kg	850/3580	850/4010	730/4440	820/5000	810/5790
	2.5	Axle load, fork retracted, laden		drive end/load end	kg	1820/2610	1950/2910	2030/3140	2180/3640	2420/4190
Tyres/chassis	3.1	Tyres				Polyurethane	Polyurethane	Polyurethane	Polyurethane	
	3.2	Tyre size		drive end	mm	∅ 360 x 130	∅ 360 x 130	∅ 360 x 130	∅ 360 x 130	
	3.3	Tyre size		load end	mm	∅ 285 x 100	∅ 285 x 100	∅ 285 x 100	∅ 350 x 100	
	3.5	Number of wheels (x = driven)		drive end/load end		1x/2	1x/2	1x/2	1x/2	
	3.7	Track width		load end	mm	1167	1167	1167	1167	
Dimensions	4.1	Tilt of mast/fork carriage		forward/backward	α/β	°	0/4	0/4	0/4	0/4
	4.2	Height		mast lowered	h ₁	mm	2450	2450	2450	2450
	4.3	Free lift			h ₂	mm	1672	1672	1662	1610
	4.4	Lift			h ₃	mm	5532	5532	5362	5362
		Maximum storage height				mm	5400	5400	5230	5230
	4.5	Height		mast extended	h ₄	mm	6643	6643	7261	7261
	4.7	Height of overhead guard (incl. automation)			h ₆	mm	2475	2475	2475	2475
	4.8	Seat height relating to SIP/stand height			h ₇	mm	1140	1140	1140	1140
	4.10	Height of wheel arms			h ₈	mm	308	308	373	373
	4.19	Overall length			l ₁	mm	2412	2448	2458	2602
	4.20	Length to face of forks			l ₂	mm	1249	1285	1295	1367
	4.21	Overall width			b ₁ /b ₂	mm	1526	1526	1526	1526
	4.22	Fork dimensions DIN ISO 2331			s/e/l	mm	50/100/1250	50/100/1250	50/100/1250	50/100/1250
	4.23	Fork carriage ISO 2328, class/type A, B					2/A	2/A	2/A	2/A
	4.24	Fork carriage width			b ₃	mm	760	760	760	760
	4.25	Distance between fork arms		min./max.	b ₅	mm	520/620	520/620	520/620	520/620
	4.26	Distance between wheel arms/loading surfaces			b ₄	mm	920	920	920	920
	4.28	Reach distance			l ₄	mm	449	529	591	623
	4.31	Ground clearance, laden, below mast			m ₁	mm	49	49	49	49
	4.32	Ground clearance, centre of wheel base			m ₂	mm	70	70	70	50
4.34.1	Aisle width for pallets 1000 x 1200 crossways			A _{st}	mm	3275	3300	3325	3400	
4.34.2	Aisle width for pallets 800 x 1200 lengthways			A _{st}	mm	3425	3450	3475	3525	
4.35	Turning radius			W _a	mm	1674	1774	1844	1912	
4.37	Length across wheel arms			l ₇	mm	1685	1791	1863	1968	
4.43	Step height				mm	345	345	345	345	
Performance data	5.1	Travel speed		laden/unladen	m/s	1.7/1.7	1.7/1.7	1.7/1.7	1.7/1.7	1.7/1.7
	5.1.1	Travel speed backwards		laden/unladen	m/s	0.8/0.8	0.8/0.8	0.8/0.8	0.8/0.8	0.8/0.8
	5.2	Lifting speed		laden/unladen	m/s	0.47/0.70	0.45/0.68	0.45/0.68	0.37/0.58	0.34/0.50
	5.3	Lowering speed		laden/unladen	m/s	0.56/0.50	0.56/0.52	0.55/0.52	0.53/0.50	0.52/0.50
	5.4	Reaching speed		laden/unladen	m/s	0.18	0.18	0.18	0.18	0.18
	5.9	Acceleration time		laden/unladen	m/s ²	0.4/0.4	0.4/0.4	0.4/0.4	0.4/0.4	0.4/0.4
	5.10	Service brake					Regenerative electric/hydraulic	Regenerative electric/hydraulic	Regenerative electric/hydraulic	Regenerative electric/hydraulic
Electric engine	6.1	Drive motor rating S2 = 60 min			kW	6.5	6.5	6.5	6.5	6.5
	6.2	Lift motor rating S3 = 15%			kW	14	14	14	14	14
	6.3	Battery according to DIN 43531/35/36 A, B, C, no				3PzS	3PzS	3PzS	4PzS	5PzS
	6.4	Battery voltage/nominal capacity Ks			V/Ah	48/465	48/465	48/465	48/620	48/775
	6.5	Battery weight (depending on manufacturer ±5%)			kg	750	750	750	940	1120
	6.6	Energy consumption according to VDI cycle			kWh/h	3.23	3.4	3.56	3.59	4.49
Misc.	10.1	Operating pressure for attachments			bar	200	200	200	200	200
	10.2	Oil volume for attachments			l/min	20	20	20	20	20

Please note: This is a sample configuration. Depending on the use of the truck, the values may differ.



The FM-X iGo systems is equipped with a pallet positioning sensor for precise and efficient pallet handling even at the highest levels of the shelving



Automatic opportunity charging via charging contacts located on the overhead guard for a fully automated process



Maximum operator safety thanks to reliable 360-degree safety lasers on the truck



Maximum precision through navigation laser on the overhead guard



FM-X iGo Automated Reach Truck Mast Tables

		FM-X 12 iGo - FM-X 14 iGo											FM-X 12 iGo		FM-X 14 iGo														
Triplex mast	Height, mast lowered	h_1	mm	1950	2015	2050	2200	2250	2300	2400	2450	2500	2600	2700	2800	2900	2800	2900	2800	2900	3000	3100	3200	3300	3400	3500	3600	3700	3800
	Free lift	h_2	mm	1172	1237	1272	1422	1472	1522	1622	1672	1722	1822	1922	2022	2122	2022	2122	2222	2322	2422	2522	2622	2722	2822	2922	3022		
	Lift	h_3	mm	4032	4222	4332	4782	4932	5082	5382	5532	5682	5982	6282	6482	6782	6582	6882	7182	7482	7782	8082	8382	8682	8982	9282	9582		
	Height, mast extended	h_4	mm	5143	5333	5443	5893	6043	6193	6493	6643	6793	7093	7393	7593	7893	7693	7993	8293	8593	8893	9193	9493	9793	10093	10393	10693		
	Maximum storage height	mm	3900	4090	4200	4650	4800	4950	5250	5400	5550	5850	6150	6350	6650	6450	6750	7050	7350	7650	7950	8250	8550	8850	9150	9450			

		FM-X 20 iGo											FM-X 12 iGo		FM-X 14 iGo												
Triplex mast	Height, mast lowered	h_1	mm	1950	2015	2050	2200	2250	2300	2400	2450	2500	2600	2700	2800	2900	3000	3100	3200	3300	3400	3450	3500	3600	3700	3800	3900
	Free lift	h_2	mm	1162	1227	1262	1412	1462	1512	1612	1662	1712	1812	1912	2012	2112	2212	2312	2412	2512	2612	2662	2712	2812	2912	3012	3112
	Lift	h_3	mm	3862	4052	4162	4612	4762	4912	5212	5362	5512	5812	6112	6412	6712	6982	7282	7582	7782	8082	8232	8382	8682	8982	9282	9582
	Height, mast extended	h_4	mm	4973	5163	5273	5723	5873	6023	6323	6473	6623	6923	7223	7523	7823	8093	8393	8693	8893	9193	9343	9493	9793	10093	10393	10693
	Maximum storage height	mm	3730	3920	4030	4480	4630	4780	5080	5230	5380	5680	5980	6280	6580	6850	7150	7450	7650	7950	8100	8250	8550	8850	9150	9450	

		FM-X 25 iGo											FM-X 12 iGo		FM-X 14 iGo												
Triplex mast	Height, mast lowered	h_1	mm	1950	2015	2050	2200	2250	2300	2400	2450	2500	2600	2700	2800	2900	3000	3100	3200	3300	3400	3450	3500	3600	3700	3800	3900
	Free lift	h_2	mm	1110	1175	1210	1360	1410	1460	1560	1610	1660	1760	1860	1960	2060	2160	2260	2360	2460	2560	2610	2660	2760	2860	2960	3060
	Lift	h_3	mm	3862	4052	4162	4612	4762	4912	5212	5362	5512	5812	6112	6412	6712	6982	7282	7582	7782	8082	8232	8382	8682	8982	9282	9582
	Height, mast extended	h_4	mm	4973	5163	5273	5723	5873	6023	6323	6473	6623	6923	7223	7523	7823	8093	8393	8693	8893	9193	9343	9493	9793	10093	10393	10693
	Maximum storage height	mm	3730	3920	4030	4480	4630	4780	5080	5230	5380	5680	5980	6280	6580	6850	7150	7450	7650	7950	8100	8250	8550	8850	9150	9450	

Technical Drawings

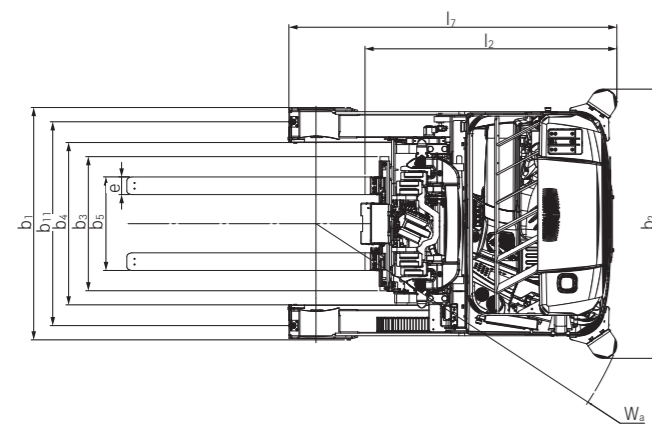

Top view FM-X iGo

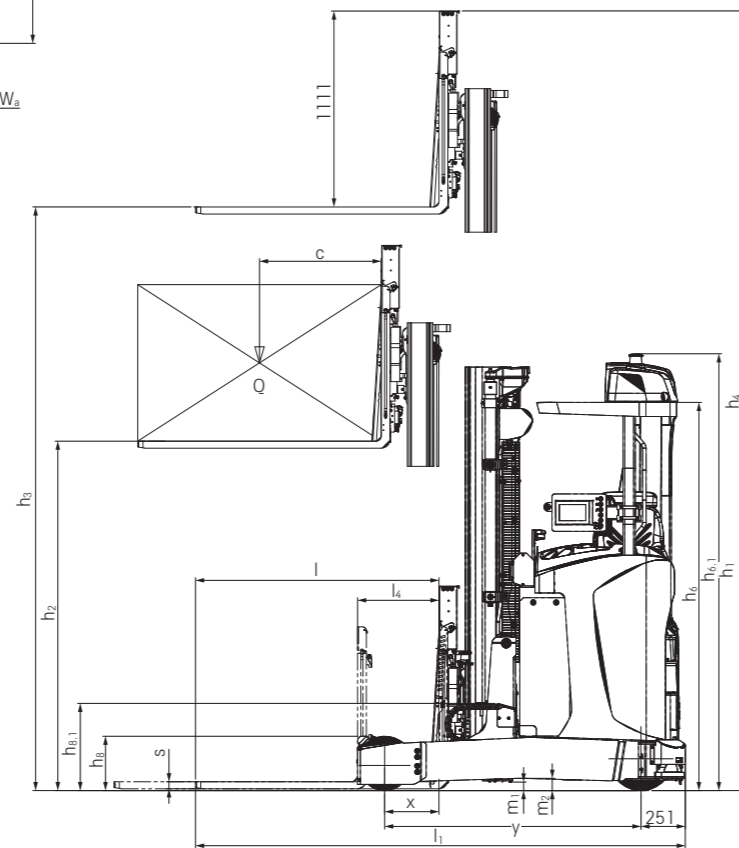

Side view FM-X iGo

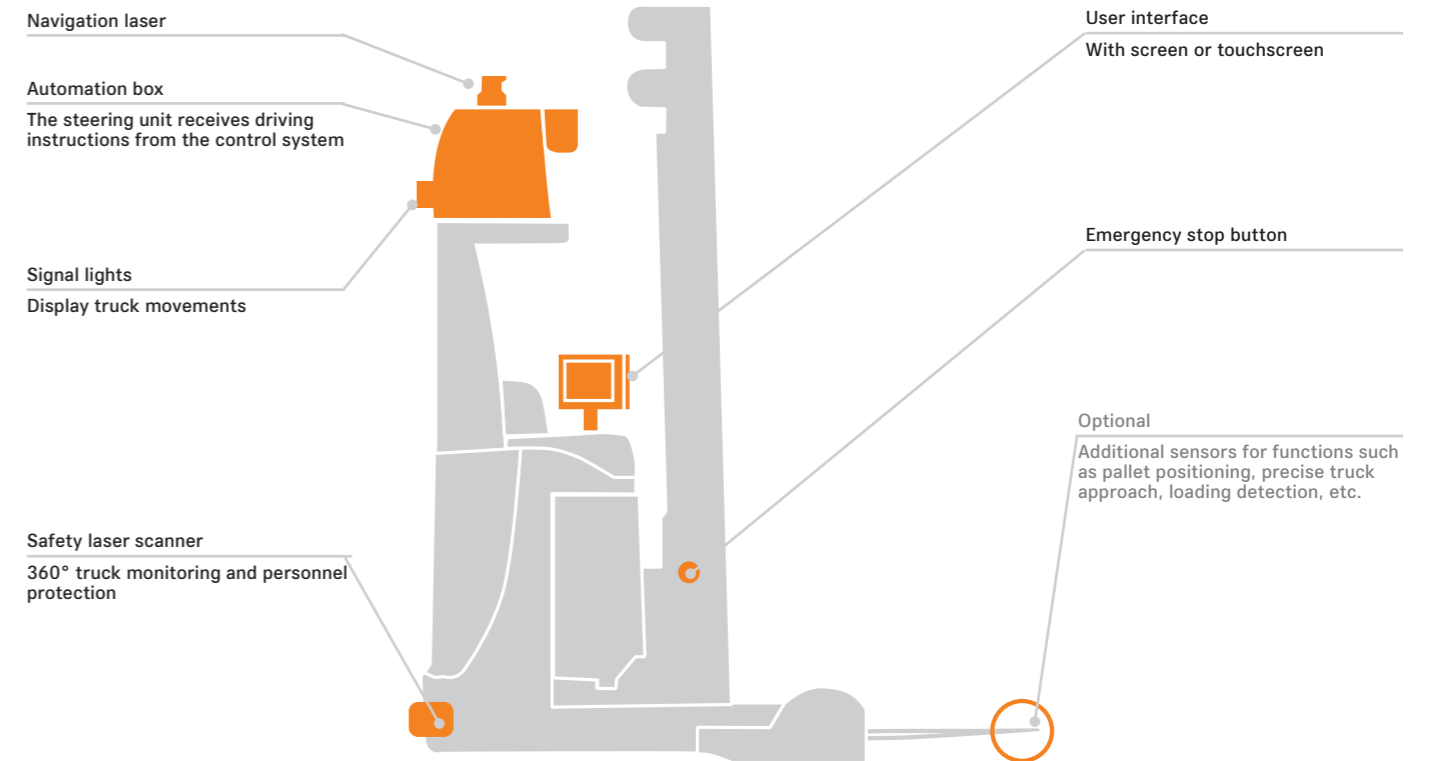

Advantages of automated reach trucks

Automated reach trucks such as the FM-X iGo are a real asset for wide-aisle and block storage both horizontally and vertically. The FM-X iGo is characterised by optimal safety and reliability for driverless transport over long distances. It also offers decisive advantages for transport tasks that require high levels of precision in challenging conditions: The automated handling improves efficiency and process reliability – for example, when storing or removing heavy loads at great heights or fully

automated shuttle systems. Automated reach trucks are therefore the perfect solution for current and future intralogistical challenges. The following safety features are integrated: a safety laser scanner that detects people and objects in the path of travel; visual and acoustic warning systems (e. g. when changing direction of travel); and several emergency stop buttons that can be used to bring the forklift truck to an immediate standstill.

MX-X iGo Automated Very Narrow Aisle Truck

We drive automated vehicles



					STILL	STILL	STILL	
					MX-X iGo with turret head	MX-X iGo with turret head	MX-X iGo with telescopic fork unit	
Features	1.1	Manufacturer						
	1.2	Manufacturer's type designation						
	1.3	Drive			Electric	Electric	Electric	
	1.4	Operation			Manual/automated	Manual/automated	Manual/automated	
	1.5	Rated capacity/rated load	Q	kg	1400	1400	1100	
	1.6	Load centre distance	c	mm	605	605	605	
Weights	1.9	Wheel base	y	mm	2068	2212	2136	
	2.1	Service weight (incl. battery)		kg	9190	11863	10287	
	2.2	Axle load, laden	drive end/load end	kg	2880/7559	3906/9207	3240/8097	
Tyres/chassis	2.3	Axle load, unladen	drive end/load end	kg	3595/5444	4602/7110	3946/6191	
	3.1	Tyres			Polyurethane	Polyurethane	Polyurethane	
	3.2	Tyre size	drive end		406/170	406/170	406/170	
	3.3	Tyre size	load end		370/160	370/160	370/160	
	3.5	Number of wheels (x = driven)	drive end/load end		1x/2	1x/2	1x/2	
	3.6	Track width	drive end/load end	b ₁₀ /b ₁₁	mm	1345/0	1395/0	1245/0
Dimensions	4.2	Height	mast lowered	h ₁	mm	3400	5900	6400
	4.3	Free lift		h ₂	mm	2150	4650	-
	4.4	Lift		h ₃	mm	6350	12850	10000
		Maximum storage height			mm	7800	14000	11350
	4.5	Height	mast extended	h ₄	mm	8950	15450	12555
	4.7	Height of overhead guard (cabin)		h ₆	mm	2555	2555	2555
	4.8	Seat height relating to SIP/stand height		h ₇	mm	460	460	460
	4.15	Fork height	lowered	h ₁₃	mm	60	60	460
	4.19	Overall length		l ₁	mm	4041	4185	4334
	4.21	Overall width		b ₁ /b ₂	mm	1160/1550	1160/1600	1160/1450
	4.22	Fork dimensions DIN ISO 2331		s/e/l	mm	50/120/1210	50/120/1200	65/174/1200
	4.24	Fork carriage width		b ₃	mm	710	710	830
	4.25	Distance between fork arms	min./max.	b ₅	mm	470/640	470/641	545/545
	4.29	Shift, sideways		b ₇	mm	1365	1385	1395
	4.31	Ground clearance, laden, below mast		m ₁	mm	40	40	40
	4.32	Ground clearance, centre of wheel base		m ₂	mm	87	87	87
	4.34.2	Aisle width for pallets 800 x 1200 lengthways		A _{st}	mm	1800	1800	1500
	4.35	Turning radius		W _a	mm	2333	2477	2401
	4.38	Distance fork pivot point		l ₈	mm	1053	1053	1303
	4.39	Length of shift carriage		A	mm	480	480	-
4.40	Width of shift frame		B	mm	1495	1540	-	
4.41	Width of shift carriage		F	mm	287	297	-	
4.42	Transfer aisle width	min.	Au	mm	6000	6000	6000	
4.44	Clearance cabin entrance			mm	412	412	412	
4.45	Clearance inside cabin			mm	2000	2000	2000	
Performance data	5.1	Travel speed	(depending on the safety concept)	m/s	1.2/2.0/3.0	1.2/2.0/3.0	1.2/2.0/3.0	
	5.1.1	Travel speed backwards	(depending on the safety concept)	m/s	1.2/2.0/3.0	1.2/2.0/3.0	1.2/2.0/3.0	
	5.2	Lifting speed	laden/unladen	m/s	0.45/0.45	0.35/0.35	0.35/0.35	
	5.3	Lowering speed	laden/unladen	m/s	0.45/0.45	0.35/0.35	0.35/0.35	
	5.9	Acceleration time	laden/unladen	m/s ²	0.4/0.4	0.4/0.4	0.4/0.4	
5.10	Service brake				Regenerative	Regenerative	Regenerative	
Electric engine	6.1	Drive motor rating S2 = 60 min		kW	7.0	7.0	7.0	
	6.2	Lift motor rating S3 = 15 %		kW	24.0	24.0	24.0	
	6.3	Battery according to DIN 43531/35/36 A, B, C, no			5PzS	6PzS	5PzS	
	6.4	Battery voltage/nominal capacity K _S		V/Ah	80/775	80/840	80/700	
	6.5	Battery weight (depending on manufacturer ±5 %)		kg	1863	2178	1863	

Please note: This is a sample configuration. Depending on the use of the truck, the values may differ.

This specification sheet, which conforms to VDI guideline 2198, provides the technical values for the standard equipment only. Different tyres, other masts, additional equipment, etc. may produce different values.

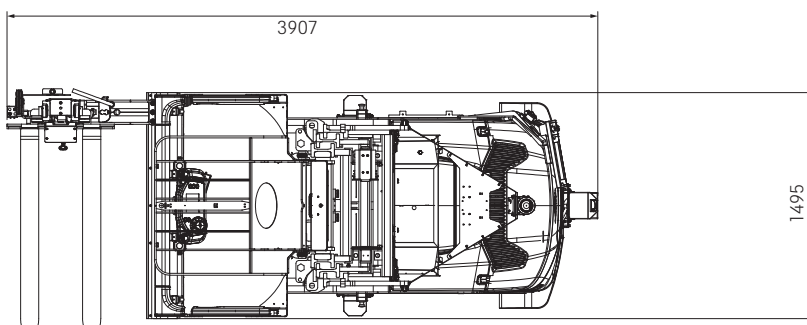

MX-X iGo systems with turret head

MX-X iGo Automated Very Narrow Aisle Truck
 Technical Drawings

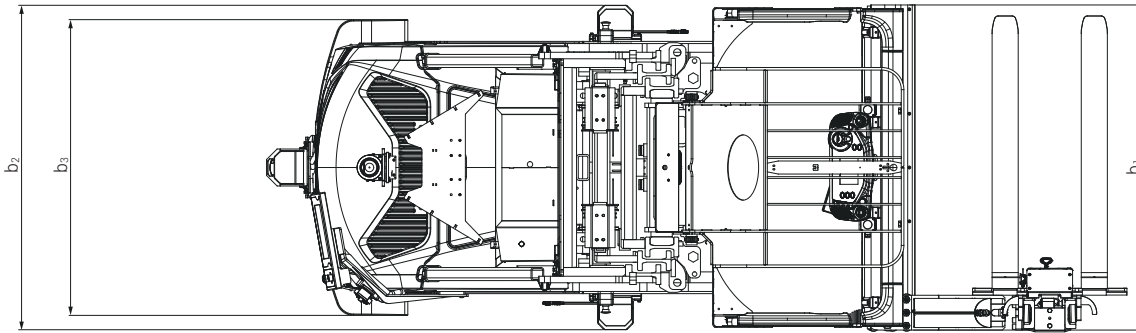

MX-X iGo with turret head and inductive guidance
 Top view

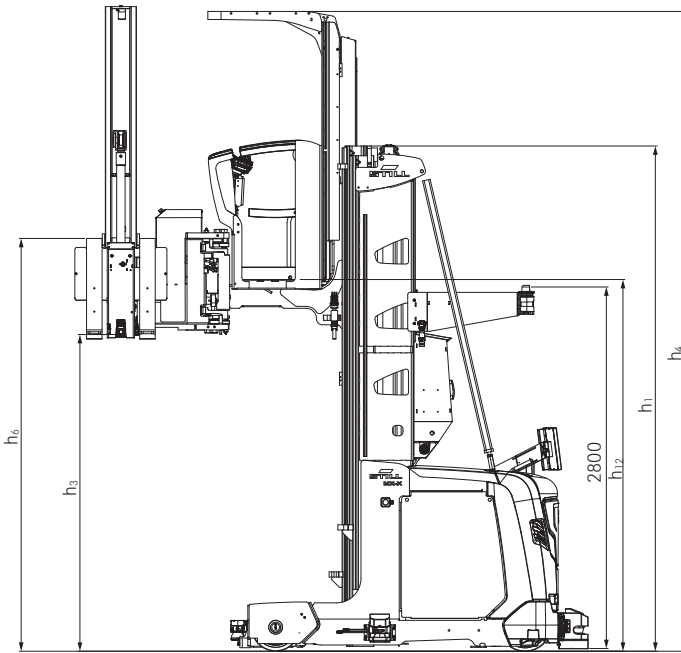

MX-X iGo with turret head and inductive guidance
 Side view

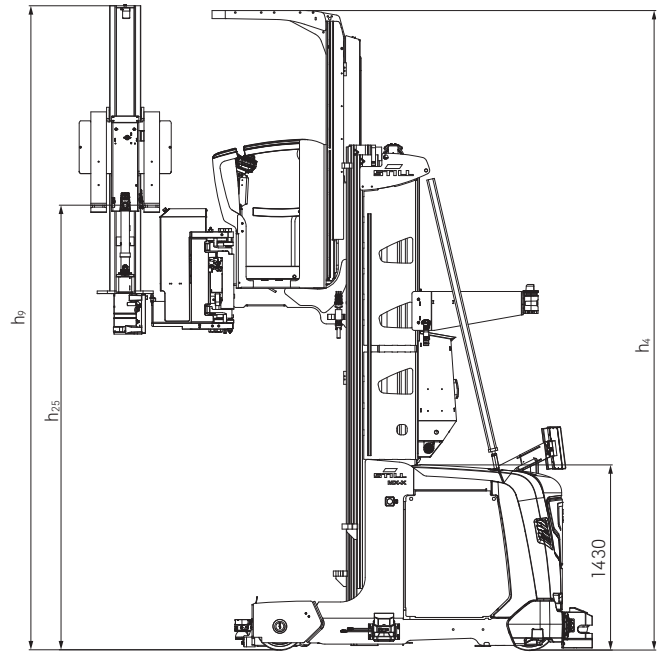

MX-X iGo with telescopic fork and inductive guidance
 Side view

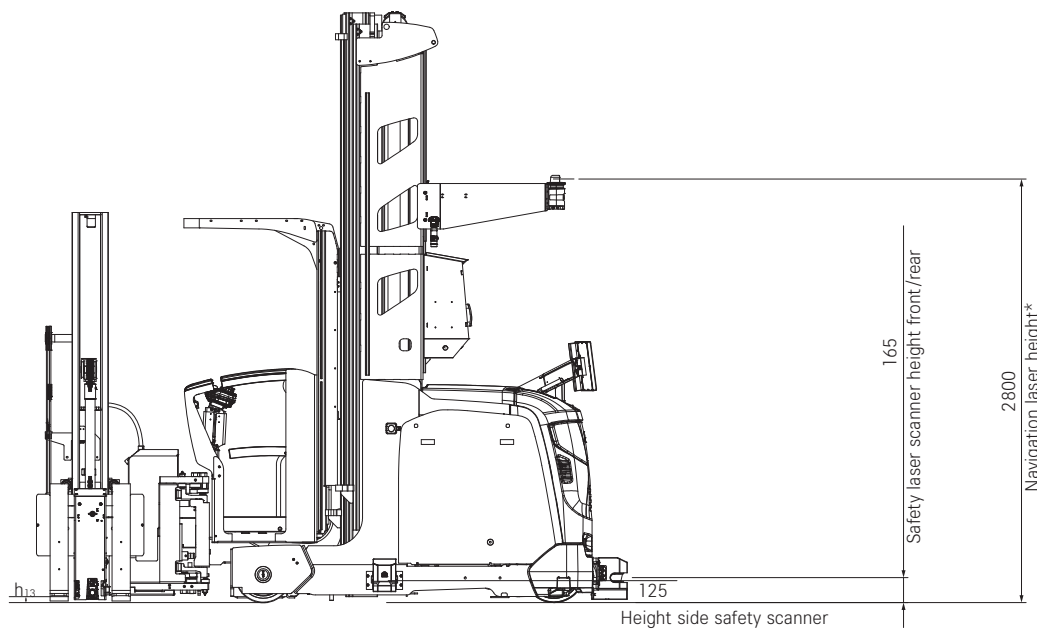

MX-X iGo with turret head
 Side view

* project-based value, given as an example

MX-X iGo Automated Very Narrow Aisle Truck Mast Tables



MX-X iGo with turret head (incl. additional lift)

				Telescopic mast								
Height	h_1	mm	2900	3400	3900	4400	4900	5400	5900	6400	6900	7400
Nominal lift	h_3	mm	3200	4200	5200	6200	7200	8200	9000	10000	10800	11800
Maximum storage height in automated mode		mm	4650	5650	6650	7650	8650	9650	10450	11450	12250	13250

				Triplex mast							
Height	h_1	mm	2900	3400	3900	4400	4900	5400	5900	6400	6900
Nominal lift	h_3	mm	5050	6350	7450	8750	10050	11550	12850	14350	15650
Maximum storage height in automated mode		mm	6500	7800	8900	10200	11500	13000	14000	14000	14000

MX-X iGo with telescopic fork unit

				Telescopic mast								
Height	h_1	mm	2900	3400	3900	4400	4900	5400	5900	6400	6900	7400
Nominal lift	h_3	mm	3200	4200	5200	6200	7200	8200	9000	10000	10800	11800
Maximum storage height in automated mode		mm	3550	4550	5550	6550	7550	8550	9350	10350	11150	12150

				Triplex mast							
Height	h_1	mm	2900	3400	3900	4400	4900	5400	5900	6400	6900
Nominal lift	h_3	mm	5050	6350	7450	8750	10050	11550	12850	14350	15650
Maximum storage height in automated mode		mm	5400	6700	7800	9100	10400	11900	13200	14000	14000

Detailed Photos



Excellent operator safety thanks to highly sensitive 360-degree safety laser on the truck



The sensitive navigation laser in the upper area of the truck enables maximum precision, efficiency and safety



Charging contacts in the lower part of the truck enable fully automated charging processes



Eye-catching warning lights for maximum visibility and recognition of the truck



Flexibility to store and retrieve on both sides of the aisle with the help of the turret head



The MX-X iGo is equipped with a telescopic fork for maximum storage density

MX-X iGo Automated Very Narrow Aisle Truck

We drive automated vehicles



Advantages of automated very narrow aisle trucks

Maximum performance and safety in the most confined spaces - a given with very narrow aisle trucks such as the MX-X iGo. This truck sets standards wherever the available space is to be used optimally. Its narrow aisle width and automated load cycles up to a height of 14 metres at a load capacity of 1,400 kg enable a particularly high degree of space utilisation as well as top-level handling performance. With absolute precision, maximum safety and stability even at lofty heights, the MX-X iGo is the perfect partner for reliable automated warehouses. Fully automated, the vehicle increases efficiency and minimises the susceptibility to errors when storing and retrieving heavy loads at great heights. Maximum safety is achieved with the following integrated safety features: Safety laser scanners to detect people and objects

in the path of travel, optical and acoustic warning devices (e. g. when changing direction) as well as several emergency stop switches to stop the vehicle immediately.

The automated STILL trucks can be easily connected to your own systems, e. g. for warehouse management. Automation kits with standardised components, controls and interfaces turn a series-produced truck into an industrialised AGV (automated guided vehicle). In this context, the following is particularly important to us:

Not every technological innovation is the economically appropriate one for your task. We offer you reliable and scalable solutions for your automation requirements - precisely tailored to your intralogistics.

STILL iGo Automation Solutions

We drive automated vehicles

Maximum safety: Smart safety functions increase transport quality and eliminate risks of accidents and damage to people, vehicles, storage equipment and goods

Outstanding process excellence: Avoiding mispicks and empty runs increases transport quality

Maximum availability: Efficient transport control and IT integration enable optimal fleet utilisation around the clock

Optimum cost-effectiveness and efficiency through individual automation concepts as well as transparent and optimised continuous material flow

iGo

STILL iGo - Automation Solutions

We make automation smart. From flexible plug & play solutions (STILL iGo easy) to highly customised system solutions (STILL iGo systems),

scalable STILL iGo covers the entire spectrum of automation. Precisely tailored to your needs.

STILL iGo easy

Our smart plug & play solution STILL iGo easy is the perfect choice for anyone who wants to automate individual logistic transport processes with small fleets. iGo easy is particularly easy and quick to implement thanks to its intuitive user interface and flexibility. And as your needs grow or your processes become more complex, you can always upgrade to iGo systems.

STILL iGo systems

Do you already have complex or interlinked logistics processes and want to automate them individually? Then iGo systems is the perfect solution for you. The highly customisable system enables vehicles to be controlled in perfectly synchronised interaction and integrated into comprehensive logistics processes - scalable from individual vehicles to entire fleets.

The 'Simply Efficient' factors: Performance attributes as a measure of economic efficiency



Simply easy

- With iGo systems vehicles, additional vehicles can be added at any time so as to expand transportation capacity



Simply powerful

- Software-based transport controls enable optimal fleet utilisation, whilst guaranteeing a high level of process reliability, traffic management, visualisation of truck movements, battery charge status monitoring and reduced error rates - the flow of materials and information is always reliable and mapped comprehensively and transparently



Simply safe

- iGo systems vehicles improve transport quality and eliminate the risk of injury and damage to people, trucks, warehouse equipment and goods thanks to smart safety functions



Simply flexible

- iGo systems trucks can also be operated manually if required: This increases flexibility, safeguards process and material flow and enables easy access to goods



Simply connected

- Different iGo systems trucks can be combined with one another, as well as with manual transport systems and stationary automation systems



**Customised and flexible:
An automated materials warehouse for Vetter**

The pharmaceutical supplier Vetter entrusted the automation experts at STILL with the planning and implementation of the logistics processes at its new, automated materials warehouse. With great success: all storage processes are fully automated within a pioneering complete system consisting of a racking system with 16,200 storage locations, MX-X iGo very narrow aisle trucks with the STILL iGo pilot navigation assistance system, and EXV iGo high lift pallet trucks. A future-proof and flexible solution for maximum occupational safety and business resilience in times of acute skills shortages.

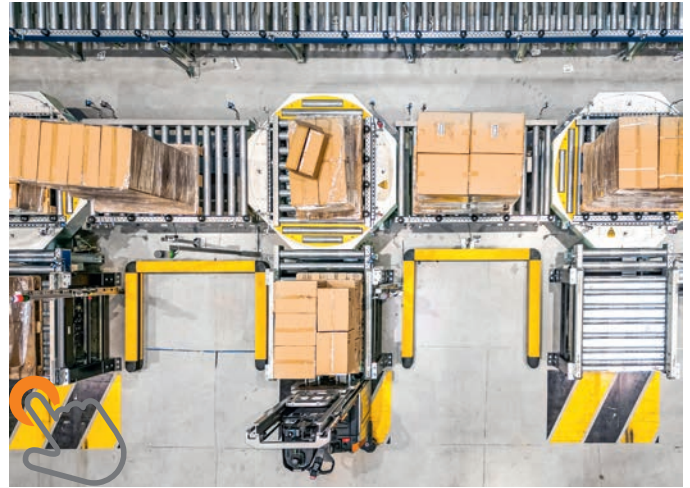

**Focus on safety:
STILL automates processes at Leroy Merlin**

With the aim of maximum occupational safety, STILL implemented a comprehensive automation project in the central warehouse of the French retail giant Leroy Merlin. The complex overall system covers around half of the 72,000 square metre warehouse and includes almost 30 automated guided vehicles, more than half of which are automated EXV iGo high lift pallet trucks. Working in perfect synchronisation with MX-X iGo very narrow aisle trucks, they process and pick around 70,000 parcels a day – error-free, accident-free and future-proof.



**A milestone in smart intralogistics:
The distribution centre of chemical group Kuraray**

At the logistics centre of the international chemical company Kuraray, STILL implemented a smart material flow concept consisting of semi-automated shuttles and automated FM-X iGo reach trucks in a channel rack warehouse with more than 3,300 storage locations. The project has been encouragingly successful in terms of system availability, flexibility, increased efficiency and optimised use of space.



**Our service offerings
for your automated systems:**

We do not compromise when it comes to the availability of your intralogistics systems. This does of course also apply to your automated systems. Whether hardware or software, maintenance or repair, we tailor our services according to your individual requirements and those of your system. This allows you to concentrate fully on your business without downtimes, waiting periods or spare parts bottlenecks. Our service technicians are highly qualified, equally as dedicated, and available 365 days a year to assist you.

Availability. Reliability. Speed.



STILL GmbH
Berzeliusstr. 10
22113 Hamburg
Germany
Tel.: +49 40 73 39 20 00
Fax: +49 40 73 39 20 01
info@still.de

For further information please visit
www.still.eu

STILL is certified in the following areas: Quality management, occupational safety, environmental protection and energy management.



first in intralogistics